

# INSTRUCTIONS FOR BISCUIT JOINERY FIXTURE FOR C1098 AND C1102 SLOT CUTTING ROUTER BITS



Biscuit joining produces very strong joints for edge -to-edge joining and for edge-to-face joining. You can use your new C1098 or C1102 Slot cutting router bits in your portable router to cut the pockets for the standard size #0, #10 and #20 biscuits rather than investing in an expensive biscuit joining machine. All you need is a simple fixture to locate and cut the biscuit pockets in your project.

The fixture can be easily constructed using the instructions below. The fixture is simply a 1/4" piece of plywood or Masonite™ with a solid strip of wood attached to the lower front edge which acts as a guide to locate against the workpiece. A semi-circular cutout in the fixture acts a guide for the router bit. The size of the slot which will be cut is determined by the distance between the bottom of the circular cutout and the workpiece. Generally it is best to make a separate fixture for each biscuit size you will be using. The vertical positioning of the slot on the edge is controlled by the depth of cut on the router. A sight hole aids in the alignment of the center of the circle with the registration line drawn on the workpiece.

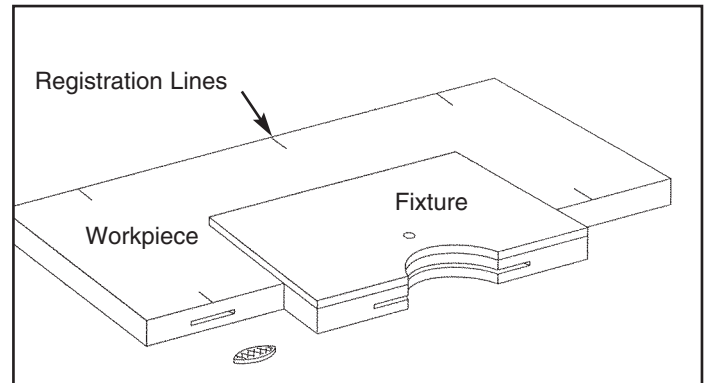

Figure 1. Biscuit fixture in use (clamps not shown for clarity).

## ⚠ WARNING

- Unplug shaper before installing or adjusting cutter.
- Keep all guards and anti-kick-back devices in place.
- Double check bit to insure it is tight and secure in spindle.
- Always inspect lumber and other wood materials for cracks, knots, or other imperfections that could cause lumber to kick or shatter while milling.

## BUILDING THE FIXTURE

1. Start with a solid piece of wood measuring approximately 8" long by 4" wide, approximately 1" thick. This piece will become the guide runner which will locate against the edge of the workpiece. With a compass or circle template, draw a circle with a 2 7/8" diameter at the edge of the board, centered along its length (See Figure 2). Use a hole saw, band saw or jig saw to cut out the circle. Don't

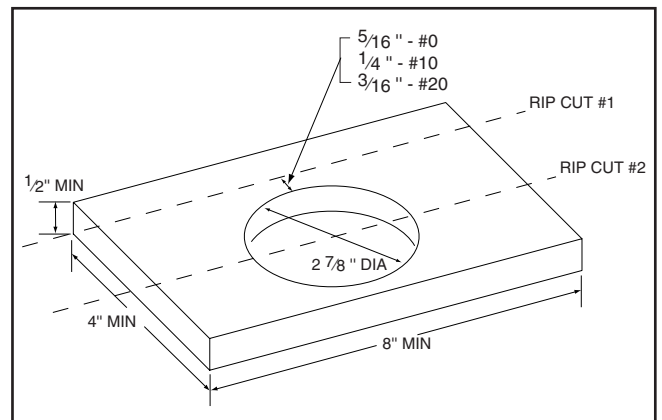

Figure 2. Laying out guide runner.

be concerned about maintaining perfect circle dimensions on the portion of the circle near the edge, as this will be cut away in a later step.

2. Determine which biscuit size you plan to use with the fixture. Measure the appropriate distance as indicated in Figure 2 from the edge of the circle, and draw a line. Rip the length of the piece along that line.
3. Do a second rip cut parallel to the first which goes through the approximate center of the 2 7/8" diameter circle. This does not need to go through the exact center of the circle, but make sure the cut leaves no

more than a half-circle shape in the runner.

4. The pattern is the surface which the router plate will sit on. Take a piece of plywood or Masonite™ which is approximately 1/4" thick and measures 8" wide and is the same overall length as the guide runner made above. Attach the guide runner to the edge of this piece with two or more flush mounted wood screws and wood glue. (See Figure 3) Make sure the front edge is flush with the edge of the guide runner.

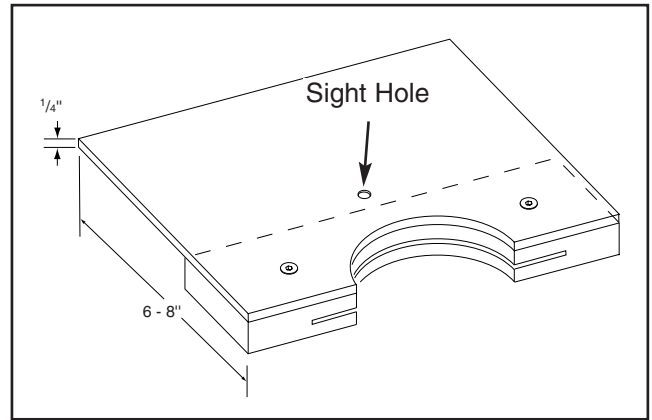

Figure 3. Attaching upper pattern guide.

5. Use a flush trimming bit in your router to cut the semi-circular arc in the pattern, using the runner as a guide. You can also trim all the other edges so they are flush.

6. Drill a sight hole through the pattern about 5/8 - 3/4" from the apex of the circular cutout. This hole will be used to line up the fixture on the positioning mark in your workpiece.

7. Attach the fixture to the edge of a scrap piece and clamp it securely in place. With the slot cutting bit installed in your router, make sure the depth is set so the slot will be cut in the middle of the thickness of the guide runner. Carefully ease the router into the runner and, with the bit's guide bearing, follow the curvature of the circle. Slot all the way around the circle, and about halfway along the straight length of the runner. You may want to adjust the depth of cut up or down and take successive cuts so the slot in the fixture will be wider than the slot you are cutting in the workpiece.

### CUTTING A BISCUIT POCKET

## ! WARNING

Performing this procedure has the potential to propel debris into the air which can cause eye injury. Always wear safety glasses or goggles when operating equipment. Be certain the safety glasses you wear meet the appropriate standards of the American National Standards Institute (ANSI).

1. Install either the C1098 or C1102 slot cutting router bit into your router. Follow the router manufacturer's instructions for mounting the router bit and be sure to follow all safety instructions.

2. Align the two pieces which are to be joined using biscuits. Mark a line across both pieces perpendicular to the face where the slot will be cut. The number of biscuits required to join two surfaces will depend upon the size of the biscuit being used and the type and condition of the wood. Generally, though, spacing between biscuits should be about 6" to 12".

3. Align the fixture along the edge of one of the pieces. Use the sight hole to center the fixture with the line you made in Step 2. Clamp the fixture to the workpiece so it will not move while routing.

4. Set the router depth of cut so the cutter will be approximately centered on the edge. It is not necessary that it be precisely centered, as long as the slots for the mating surfaces are cut from the same side of the workpiece.

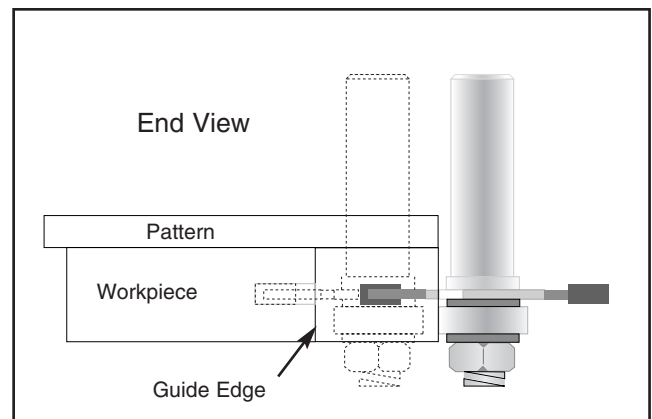

Figure 4. End view of router and fixture.

5. Set the router base plate onto the pattern top and turn the router on with the bit free of contact with the guide runner. With a firm grasp on the router, ease the router into the slot until the guide bearing of the slot cutting bit contacts the edge of the fixture. (See Figure 4) Start the cutting process at the left side of the arc and work around the circle to the right until the bit exits the fixture. Turn the router off and reposition the fixture for the next cut.