

# READ THIS FIRST



**Models G0445, G0582,  
G9962Z, & G9962ZX  
\*\*\*IMPORTANT UPDATE\*\*\***

**For Machines Mfd. Since January, 2014  
and Owner's Manual Revised June, 2006**

For questions or help with this product contact Tech Support at (570) 546-9663 or [techsupport@grizzly.com](mailto:techsupport@grizzly.com)

The following changes were recently made to this machine since the owner's manual was printed:

- Obtained CSA certification meeting CSA C22.2 #105-1953 and UL 987-7th standards.
- Changed electrical system, including a new transformer, overload relay, terminal blocks, and wiring.
- Changed circuit requirements.
- Replaced oscillation diaphragm assembly with an air cylinder.

**Note:** At the top of each page is a note that indicates which page it replaces in the original manual. On the parts list, the new parts are designated with a "V2".

Aside from this information, all other content in the owner's manual applies and **MUST** be read and understood for your own safety. **IMPORTANT: Keep this update with the owner's manual for future reference.** For questions or help, contact our Tech Support at (570) 546-9663 or [techsupport@grizzly.com](mailto:techsupport@grizzly.com).

## Electrical Parts List (Replaces Page 67)

REF	PART #	DESCRIPTION
8101	P9962Z8101	ELECTRICAL CONTROL BOX
8102	P9962Z8102	HINGE
8103	P9962Z8103	CONTROL BOX DOOR
8104	P9962Z8104	BASE PLATE
8105	PN05	HEX NUT 1/4-20
8106	PLW02	LOCK WASHER 1/4
8107	P9962Z8107	CONTROL PANEL
8108	PS07M	PHLP HD SCR M4-0.7 X 8
8109	P9962Z8109	AMP SENSOR (G9962Z)
8109	P9962ZX8109	AMP SENSOR (G0445/G9962ZX/G0582)
8110V2	P9962ZX8110V2	TRANSFORMER V2.03.10 (G0445/G9962ZX/G0582)
8111V2	P9962Z8111V2	CONTACTOR TELE LC1D50A 220V V2.11.10 (G9962Z)
8111	P9962ZX8111	CONTACTOR TELE LC1D386 220V (G0445/G9962ZX/G0582)
8112	P9962ZX8112	OL RELAY TELE LR3D326 23-32A (G0445/G9962ZX/G0582)
8113V2	P9962Z8113V2	FUSE HOUSING V2.03.10
8113V2-1	P9962Z8113V2-1	FUSE 4 AMP V2.03.10
8114	P9962Z8114	OL RELAY TELE LR3D126 5.5-8A (G9962Z)

### 440V CONVERSION PARTS

8135	P9962ZX8135	OL RELAY TELE LR3D216 12-18A (G0445/G9962ZX/G0582)
8136	P9962ZX8136	OL RELAY TELE LR3D076 1.6-2.5A (G0445/G9962ZX/G0582)

REF	PART #	DESCRIPTION
8114	P9962ZX8114	OL RELAY TELE LR3D086 2.5-4A (G0445/G9962ZX/G0582)
8115	P9962Z8115	CONTACTOR TELE LC1D096 220V
8115-1	P9962Z8115-1	CONTACTOR 2-PC ASSY LC1D096
8116V2	P9962Z8116V2	POWER TERMINAL BLOCK V2.03.10 (G9962Z)
8116V2	P9962ZX8116V2	POWER TERMINAL BLOCK V2.03.10 (G0445/G0582/G9962ZX)
8117	PS52M	PHLP HD SCR M4-0.7 X 30
8118V2	P9962Z8118V2	TERMINAL BLOCK V2.03.10 (G9962Z)
8118V2	P9962ZX8118V2	TERMINAL BLOCK V2.03.10 (G0445/G0582/G9962ZX)
8119	PW06	FLAT WASHER 1/4
8120	PLW02	LOCK WASHER 1/4
8121	PB26	HEX BOLT 1/4-20 X 1/2
8122	P9962Z8122	PU CONNECTOR 1/2
8123	P9962Z8123	PU CONNECTOR 3/4
8124	P9962Z8124	CABLE CONNECTOR 1
8126A	PH29338126A	DIGITAL AMP METER N/S
8128-1	P9962Z8128-1	START SWITCH
8128-2	P9962Z8128-2	START SWITCH
8129-1	P9962Z8129-1	STOP SWITCH
8129-2	P9962Z8129-2	STOP SWITCH
8130	P9962Z8130	POWER INDICATION LIGHT
8131	P9962Z8131	EMERGENCY STOP SWITCH
8132	P9962Z8132	WIRE COLUMN
8133	P9962Z8133	CPU
8134	P9983627	OL RELAY TELE LT47 5-60A (G9962Z)



COPYRIGHT © APRIL, 2014 BY GRIZZLY INDUSTRIAL, INC.  
**WARNING: NO PORTION OF THIS MANUAL MAY BE REPRODUCED IN ANY SHAPE  
OR FORM WITHOUT THE WRITTEN APPROVAL OF GRIZZLY INDUSTRIAL, INC.**

#TS16504 PRINTED IN TAIWAN



# SECTION 1: SAFETY

## For Your Own Safety, Read Instruction Manual Before Operating This Machine

The purpose of safety symbols is to attract your attention to possible hazardous conditions. This manual uses a series of symbols and signal words intended to convey the level of importance of the safety messages. The progression of symbols is described below. Remember that safety messages by themselves do not eliminate danger and are not a substitute for proper accident prevention measures. Always use common sense and good judgment.



Indicates an imminently hazardous situation which, if not avoided, **WILL** result in death or serious injury.



Indicates a potentially hazardous situation which, if not avoided, **COULD** result in death or serious injury.



Indicates a potentially hazardous situation which, if not avoided, **MAY** result in minor or moderate injury. It may also be used to alert against unsafe practices.

**NOTICE**

This symbol is used to alert the user to useful information about proper operation of the machine.

## Safety Instructions for Machinery



**OWNER'S MANUAL.** Read and understand this owner's manual **BEFORE** using machine.

**TRAINED OPERATORS ONLY.** Untrained operators have a higher risk of being hurt or killed. Only allow trained/supervised people to use this machine. When machine is not being used, disconnect power, remove switch keys, or lock-out machine to prevent unauthorized use—especially around children. Make workshop kid proof!

**DANGEROUS ENVIRONMENTS.** Do not use machinery in areas that are wet, cluttered, or have poor lighting. Operating machinery in these areas greatly increases the risk of accidents and injury.

**MENTAL ALERTNESS REQUIRED.** Full mental alertness is required for safe operation of machinery. Never operate under the influence of drugs or alcohol, when tired, or when distracted.

**ELECTRICAL EQUIPMENT INJURY RISKS.** You can be shocked, burned, or killed by touching live electrical components or improperly grounded machinery. To reduce this risk, only allow qualified service personnel to do electrical installation or repair work, and always disconnect power before accessing or exposing electrical equipment.

**DISCONNECT POWER FIRST.** Always disconnect machine from power supply **BEFORE** making adjustments, changing tooling, or servicing machine. This prevents an injury risk from unintended startup or contact with live electrical components.

**EYE PROTECTION.** Always wear ANSI-approved safety glasses or a face shield when operating or observing machinery to reduce the risk of eye injury or blindness from flying particles. Everyday eyeglasses are **NOT** approved safety glasses.



## **WARNING**

**WEARING PROPER APPAREL.** Do not wear clothing, apparel or jewelry that can become entangled in moving parts. Always tie back or cover long hair. Wear non-slip footwear to avoid accidental slips, which could cause loss of workpiece control.

**HAZARDOUS DUST.** Dust created while using machinery may cause cancer, birth defects, or long-term respiratory damage. Be aware of dust hazards associated with each workpiece material, and always wear a NIOSH-approved respirator to reduce your risk.

**HEARING PROTECTION.** Always wear hearing protection when operating or observing loud machinery. Extended exposure to this noise without hearing protection can cause permanent hearing loss.

**REMOVE ADJUSTING TOOLS.** Tools left on machinery can become dangerous projectiles upon startup. Never leave chuck keys, wrenches, or any other tools on machine. Always verify removal before starting!

**USE CORRECT TOOL FOR THE JOB.** Only use this tool for its intended purpose—do not force it or an attachment to do a job for which it was not designed. Never make unapproved modifications—modifying tool or using it differently than intended may result in malfunction or mechanical failure that can lead to personal injury or death!

**AWKWARD POSITIONS.** Keep proper footing and balance at all times when operating machine. Do not overreach! Avoid awkward hand positions that make workpiece control difficult or increase the risk of accidental injury.

**CHILDREN & BYSTANDERS.** Keep children and bystanders at a safe distance from the work area. Stop using machine if they become a distraction.

**GUARDS & COVERS.** Guards and covers reduce accidental contact with moving parts or flying debris. Make sure they are properly installed, undamaged, and working correctly.

**FORCING MACHINERY.** Do not force machine. It will do the job safer and better at the rate for which it was designed.

**NEVER STAND ON MACHINE.** Serious injury may occur if machine is tipped or if the cutting tool is unintentionally contacted.

**STABLE MACHINE.** Unexpected movement during operation greatly increases risk of injury or loss of control. Before starting, verify machine is stable and mobile base (if used) is locked.

**USE RECOMMENDED ACCESSORIES.** Consult this owner's manual or the manufacturer for recommended accessories. Using improper accessories will increase the risk of serious injury.

**UNATTENDED OPERATION.** To reduce the risk of accidental injury, turn machine **OFF** and ensure all moving parts completely stop before walking away. Never leave machine running while unattended.

**MAINTAIN WITH CARE.** Follow all maintenance instructions and lubrication schedules to keep machine in good working condition. A machine that is improperly maintained could malfunction, leading to serious personal injury or death.

**CHECK DAMAGED PARTS.** Regularly inspect machine for any condition that may affect safe operation. Immediately repair or replace damaged or mis-adjusted parts before operating machine.

**MAINTAIN POWER CORDS.** When disconnecting cord-connected machines from power, grab and pull the plug—NOT the cord. Pulling the cord may damage the wires inside. Do not handle cord/plug with wet hands. Avoid cord damage by keeping it away from heated surfaces, high traffic areas, harsh chemicals, and wet/damp locations.

**EXPERIENCING DIFFICULTIES.** If at any time you experience difficulties performing the intended operation, stop using the machine! Contact our Technical Support at (570) 546-9663.



# Additional Safety for Wide Belt Sanders

## **WARNING**

Serious injury or death can occur from hands getting trapped between workpiece and conveyor table, getting entangled in rotating parts inside machine, or lacerated by sanding drum. Workpieces thrown by sander can strike nearby operators. Long-term respiratory damage can occur from using sander without proper use of a respirator and an adequate dust collection system. To minimize risk of getting hurt or killed, anyone operating machine **MUST** completely heed hazards and warnings below.

**FEEDING WORKPIECE.** DO NOT place fingers under bottom of workpiece while feeding it into sander. Fingers can become pinched between workpiece and conveyor.

**ENTANGLEMENT HAZARDS.** DO NOT wear loose clothing, gloves, or jewelry, and tie back long hair. Never reach inside operating machine or try clearing jammed workpiece. Keep all guards in place and secure, and all doors closed.

**SANDING DRUM CONTACT.** Rotating sandpaper can remove a large amount of flesh in a few seconds. Keep hands away from rotating sanding drum(s) during operation. Never touch moving sandpaper on purpose.

**WORKPIECE KICKBACK.** A workpiece can be ejected out the front of sander at high rate of speed, and hit operator or bystanders. Never stand in-line with workpiece, never feed more than one workpiece at a time, and always adjust pressure rollers below sanding roller.

**MINIMUM STOCK DIMENSION.** To avoid kick-back, never sand workpieces below minimum specifications listed in **Data Sheet**.

**ADJUSTMENTS/MAINTENANCE.** Make sure machine is turned **OFF**, disconnected from power and air, and all moving parts are completely stopped before doing adjustments or maintenance.

**SANDING DUST.** Sanding creates large amounts of dust and flying chips that can lead to eye injury or respiratory illness. Reduce risk of these hazards by wearing approved eye and respiratory protection when using sander.

**DUST COLLECTION.** Never operate without adequate dust collection system in place and running. Proper dust collection reduces dust in work area, which decreases risk of long-term respiratory damage, but it is not a substitute for using a respirator.



# SECTION 2: POWER SUPPLY

---

## Availability

Before installing the machine, consider the availability and proximity of the required power supply circuit. If an existing circuit does not meet the requirements for this machine, a new circuit must be installed. To minimize the risk of electrocution, fire, or equipment damage, installation work and electrical wiring must be done by an electrician or qualified service personnel in accordance with all applicable codes and standards.

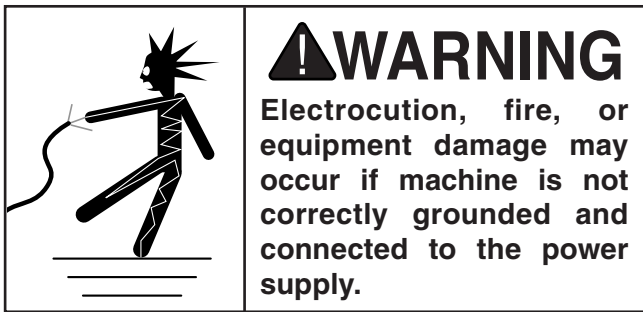

## Full-Load Current Rating

The full-load current rating is the amperage a machine draws at 100% of the rated output power. On machines with multiple motors, this is the amperage drawn by the largest motor or sum of all motors and electrical devices that might operate at one time during normal operations.

### G0445

**Full-Load Current Rating at 220V .. 29.6 Amps**  
**Full-Load Current Rating at 440V .. 14.8 Amps**

### G0582

**Full-Load Current Rating at 220V .. 29.6 Amps**  
**Full-Load Current Rating at 440V .. 14.8 Amps**

### G9962Z

**Full-Load Current Rating at 220V .. 58.6 Amps**

### G9962ZX

**Full-Load Current Rating at 220V .. 29.4 Amps**  
**Full-Load Current Rating at 440V .. 14.8 Amps**

The full-load current is not the maximum amount of amps that the machine will draw. If the machine is overloaded, it will draw additional amps beyond the full-load rating.

If the machine is overloaded for a sufficient length of time, damage, overheating, or fire may result—especially if connected to an undersized circuit. To reduce the risk of these hazards, avoid overloading the machine during operation and make sure it is connected to a power supply circuit that meets the requirements in the following section.



## In Addition to Page 13

### Circuit Information

A power supply circuit includes all electrical equipment between the breaker box or fuse panel in the building and the machine. The power supply circuit used for this machine must be sized to safely handle the full-load current drawn from the machine for an extended period of time. (If this machine is connected to a circuit protected by fuses, use a time delay fuse marked D.)

### CAUTION

**For your own safety and protection of property, consult an electrician if you are unsure about wiring practices or electrical codes in your area.**

**Note:** *The circuit requirements listed in this manual apply to a dedicated circuit—where only one machine will be running at a time. If this machine will be connected to a shared circuit where multiple machines will be running at the same time, consult a qualified electrician to ensure that the circuit is properly sized for safe operation.*

### G0445 Circuit Requirements

#### For 220V

This machine is prewired to operate on a 220V power supply circuit that has a verified ground and meets the following requirements:

**Nominal Voltage** ..... 220V, 230V, 240V  
**Cycle** ..... 60 Hz  
**Phase** ..... 3-Phase  
**Power Supply Circuit** ..... 40 Amps

#### For 440V

This machine can be converted to operate on a 440V power supply (refer to **Voltage Conversion** instructions) that has a verified ground and meets the following requirements:

**Nominal Voltage** ..... 440V, 480V  
**Cycle** ..... 60 Hz  
**Phase** ..... 3-Phase  
**Power Supply Circuit** ..... 20 Amps

### G0582 Circuit Requirements

#### For 220V

This machine is prewired to operate on a 220V power supply circuit that has a verified ground and meets the following requirements:

**Nominal Voltage** ..... 220V, 230V, 240V  
**Cycle** ..... 60 Hz  
**Phase** ..... 3-Phase  
**Power Supply Circuit** ..... 40 Amps

#### For 440V

This machine can be converted to operate on a 440V power supply (refer to **Voltage Conversion** instructions) that has a verified ground and meets the following requirements:

**Nominal Voltage** ..... 440V, 480V  
**Cycle** ..... 60 Hz  
**Phase** ..... 3-Phase  
**Power Supply Circuit** ..... 20 Amps

### G9962Z Circuit Requirements

#### For 220V

This machine is prewired to operate on a 220V power supply circuit that has a verified ground and meets the following requirements:

**Nominal Voltage** ..... 220V, 230V, 240V  
**Cycle** ..... 60 Hz  
**Phase** ..... 1-Phase  
**Power Supply Circuit** ..... 70 Amps

### G9962ZX Circuit Requirements

#### For 220V

This machine is prewired to operate on a 220V power supply circuit that has a verified ground and meets the following requirements:

**Nominal Voltage** ..... 220V, 230V, 240V  
**Cycle** ..... 60 Hz  
**Phase** ..... 3-Phase  
**Power Supply Circuit** ..... 40 Amps

#### For 440V

This machine can be converted to operate on a 440V power supply (refer to **Voltage Conversion** instructions) that has a verified ground and meets the following requirements:

**Nominal Voltage** ..... 440V, 480V  
**Cycle** ..... 60 Hz  
**Phase** ..... 3-Phase  
**Power Supply Circuit** ..... 20 Amps



## In Addition to Page 13

### Connection Type

A permanently connected (hardwired) power supply is typically installed with wires running through mounted and secured conduit. A disconnecting means, such as a locking switch (see following **Figure**), must be provided to allow the machine to be disconnected (isolated) from the power supply when required. This installation must be performed by an electrician in accordance with all applicable electrical codes and ordinances.

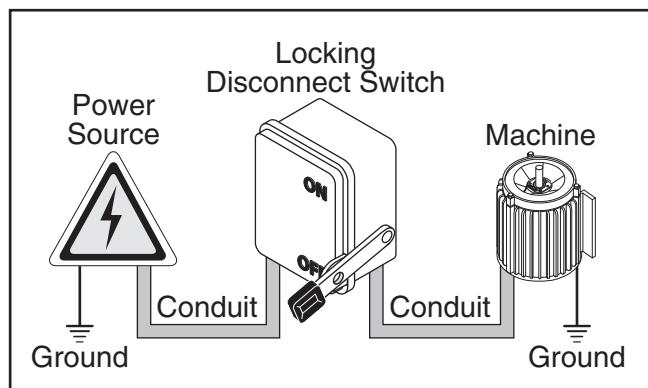

**Figure 3.** Typical setup of a permanently connected machine.

### Grounding Instructions

In the event of a malfunction or breakdown, grounding provides a path of least resistance for electrical current to reduce the risk of electric shock. A permanently connected machine must be connected to a grounded metal permanent wiring system; or to a system having an equipment-grounding conductor. All grounds must be verified and rated for the electrical requirements of the machine. Improper grounding can increase the risk of electric shock!

### **!WARNING**

**Serious injury could occur if you connect the machine to power before completing the setup process. DO NOT connect to power until instructed later in this manual.**

### Extension Cords

Since this machine must be permanently connected to the power supply, an extension cord cannot be used.



## Replaces Page 14

# 440V Connection (G0445, G0582, G9962ZX)

This machine is prewired for 220V 3-phase power but has the capability of operating on 440V power with a minor conversion. The conversion consists of replacing two overload relays and rewiring each of the three motors.

All wiring changes must be inspected by a qualified electrician or service personnel before the saw is connected to the power source. If, at any time during this procedure you need help, call Grizzly Tech Support at (570) 546-9663.

Contact the Grizzly Order Desk at (800) 523-4777 to purchase the necessary 440V overload relays (Part Numbers P9962ZX8135 and P9962ZX8136).

### To wire the sander to 440V:

1. DISCONNECT THE SANDER FROM THE POWER SOURCE!
2. Open the electrical box located on the back of the machine.
3. On the transformer, remove the wire labeled "1" connected to the 220V terminal for your model of sander, and connect it to the 440V terminal as shown in **Figure 7**.

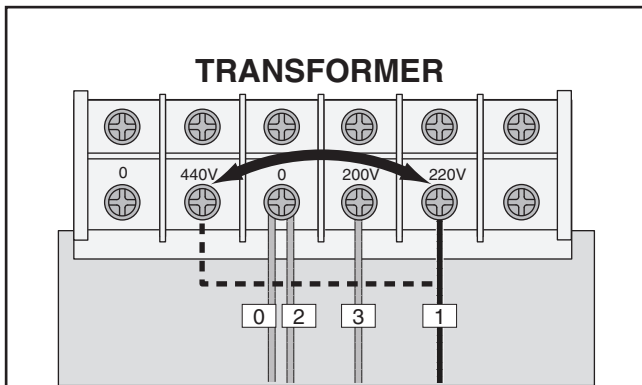

**Figure 7.** 440V transformer connection.

4. Swap out the applicable thermal relay at the locations shown in **Figure 8**, and set it to the overload values listed.

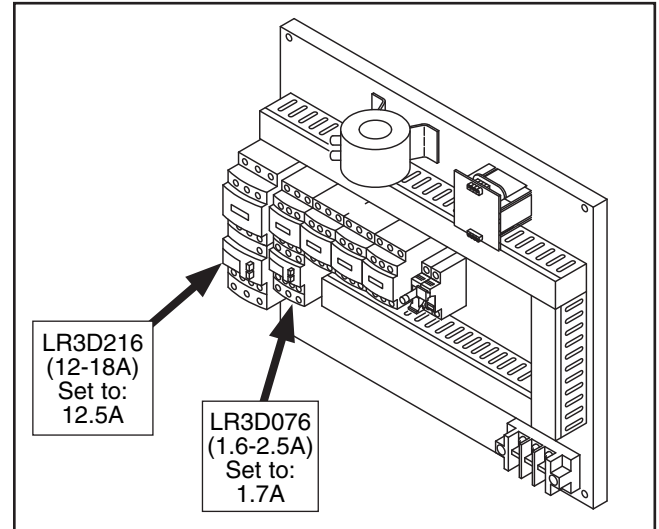

**Figure 8.** Overload relays.

5. Wire the sanding belt, conveyor belt, and table elevation motors as shown in **Motor Wiring** on **Page 44** of the owner's manual.



Replaces Page 44, Except for Motor Wiring Diagrams

# Wiring Box Diagram (G0445/G0582/G9962ZX)

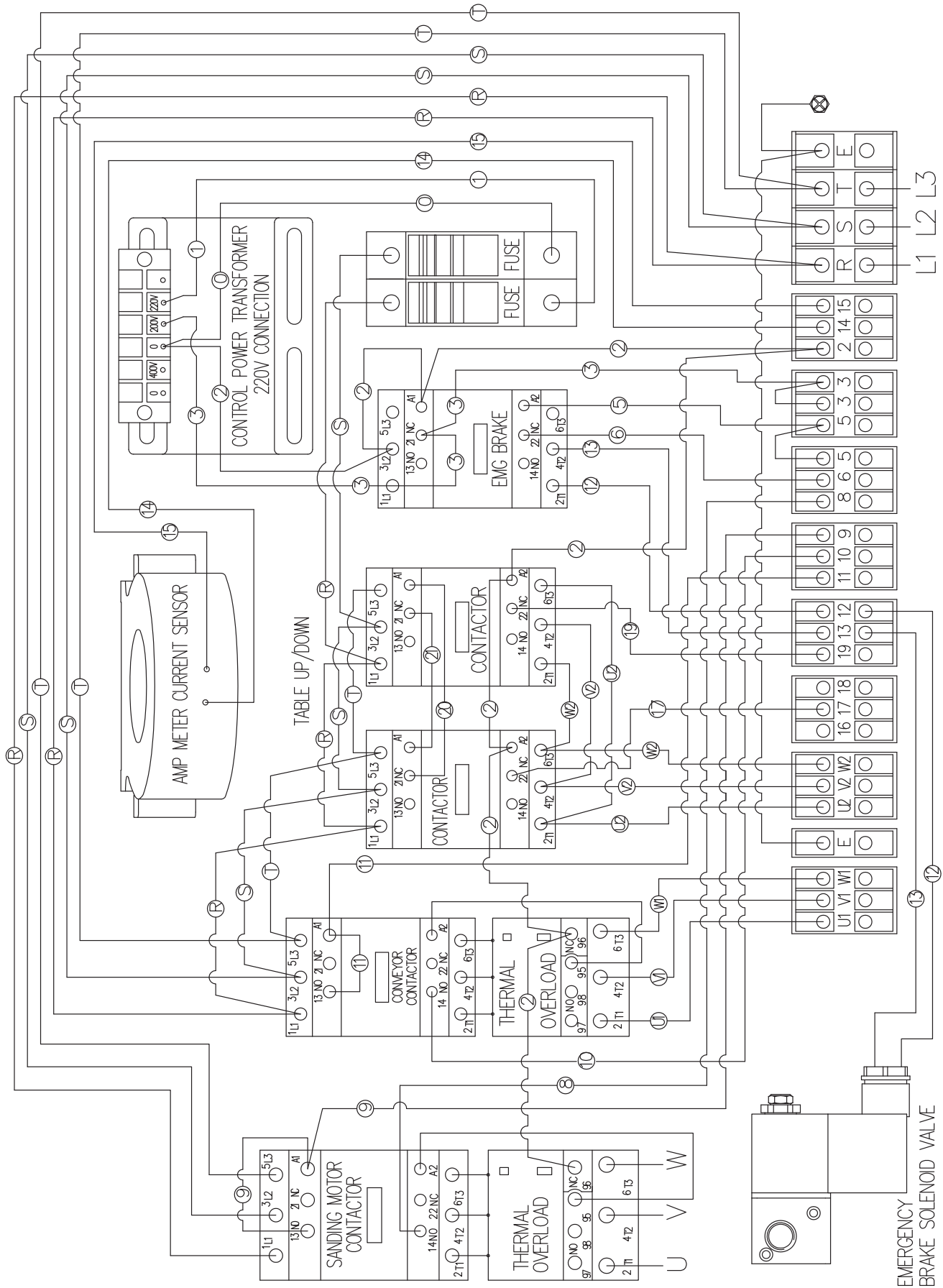

*Replaces Page 46, Except for Motor Wiring Diagrams*  
**Wiring Box Electrical Diagram (G9962Z)**

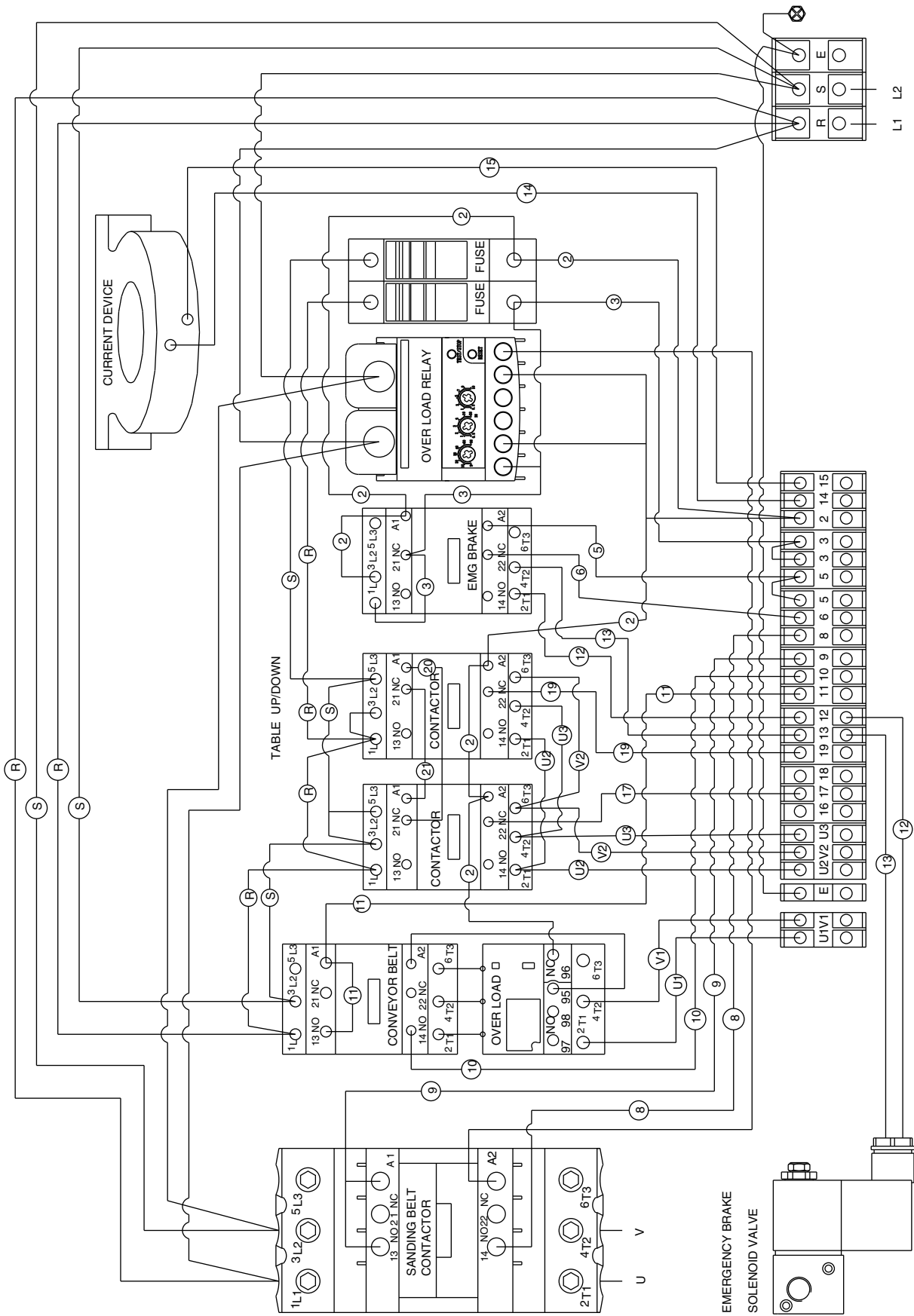

*Replaces Page 45*  
**Wiring Box (G0445/G0582/G9962ZX)**

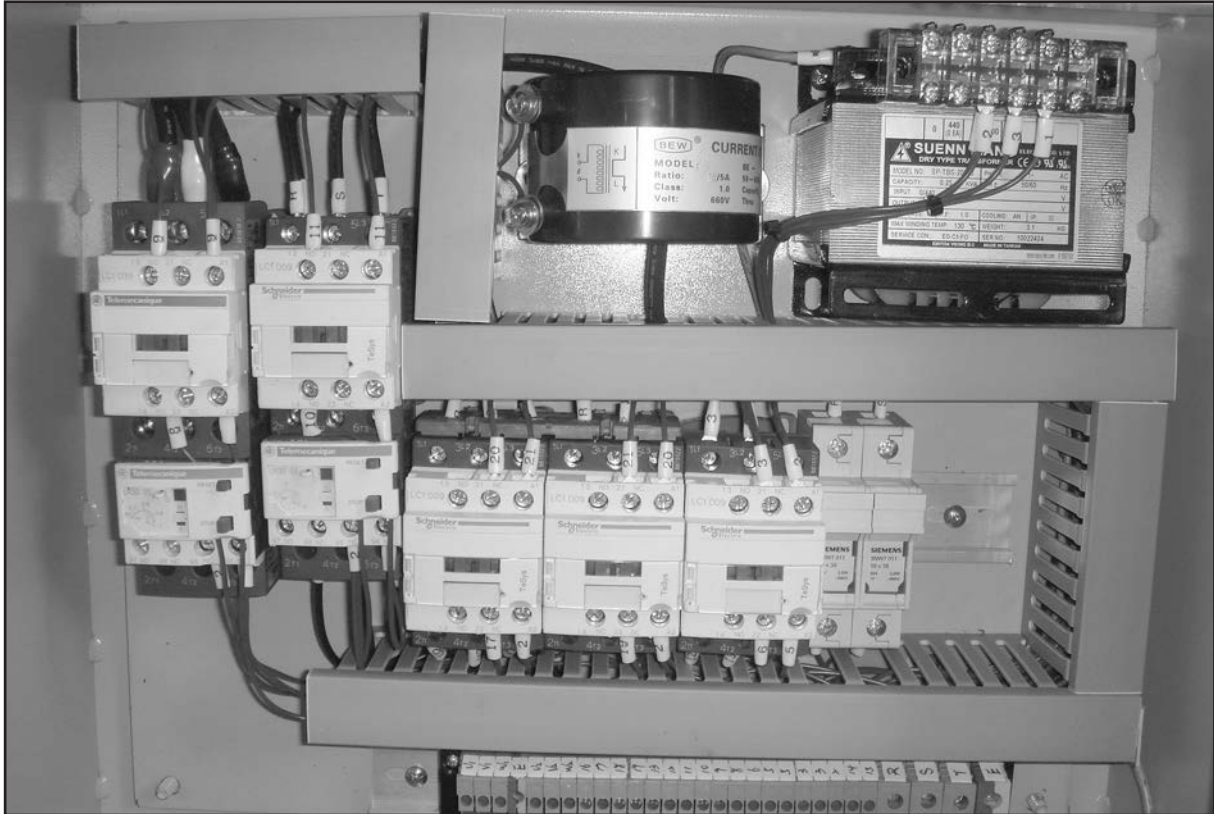

*Replaces Page 47*  
**Wiring Box (G9962Z)**

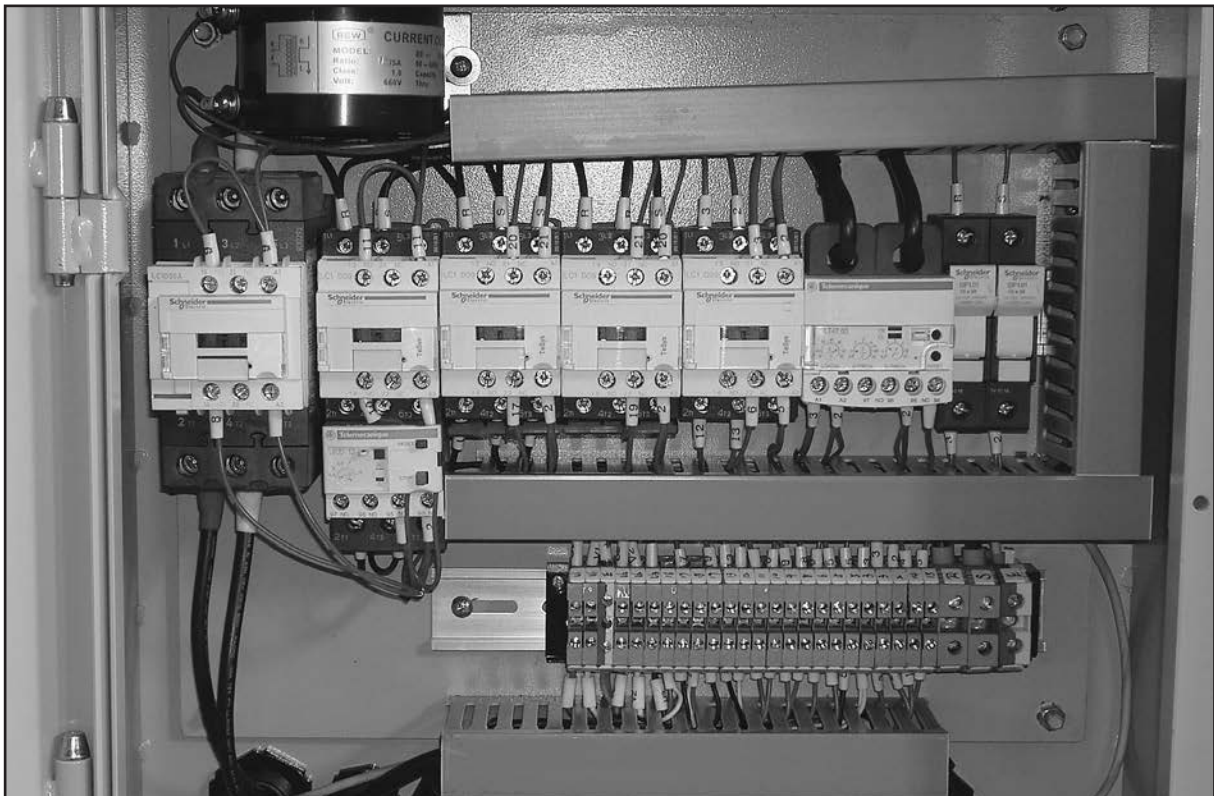

Replaces Page 48

# General Electrical (G0445/G0582/G9962ZX)

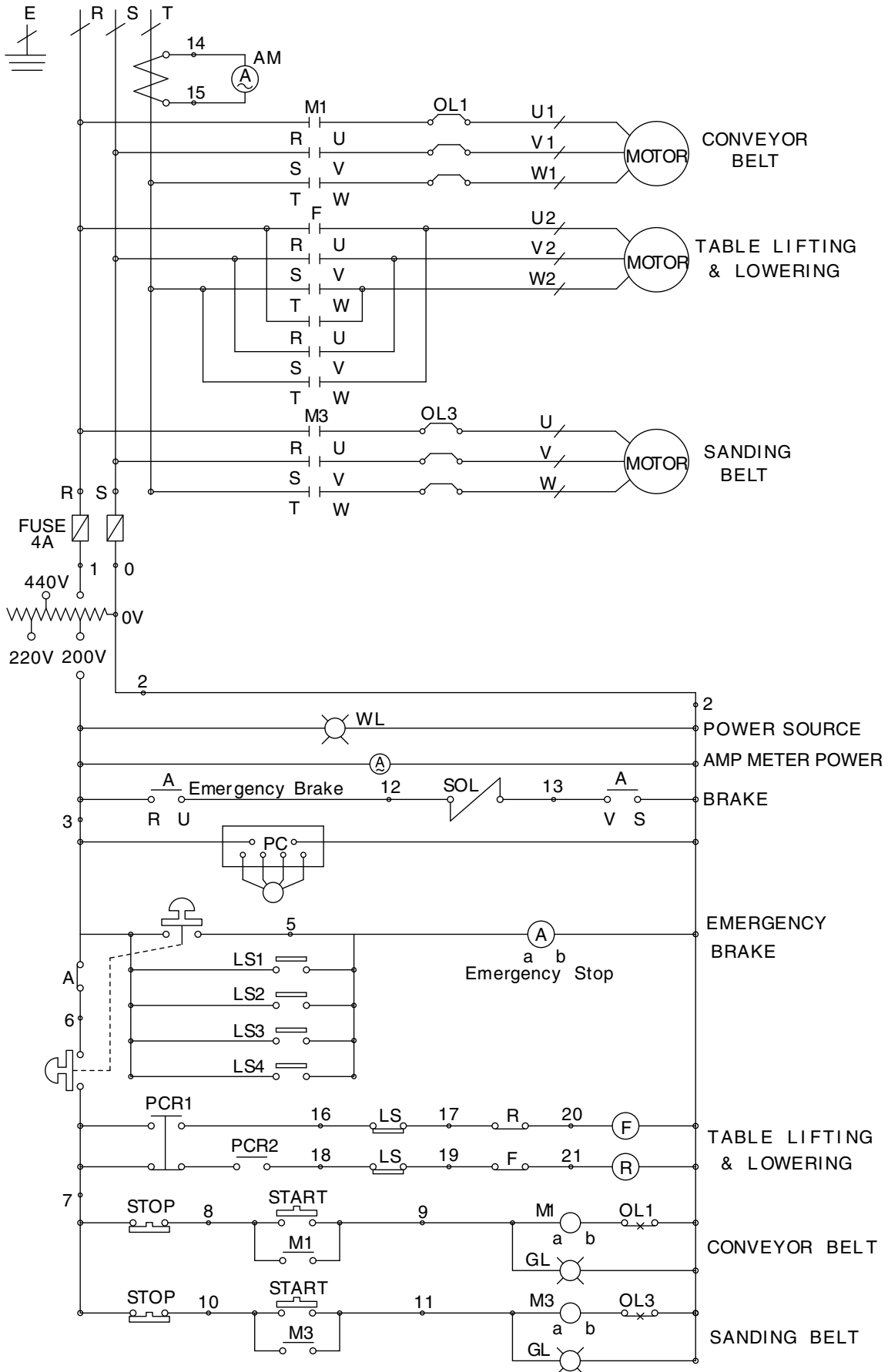

Replaces Page 49

# General Electrical Diagram (G9962Z)

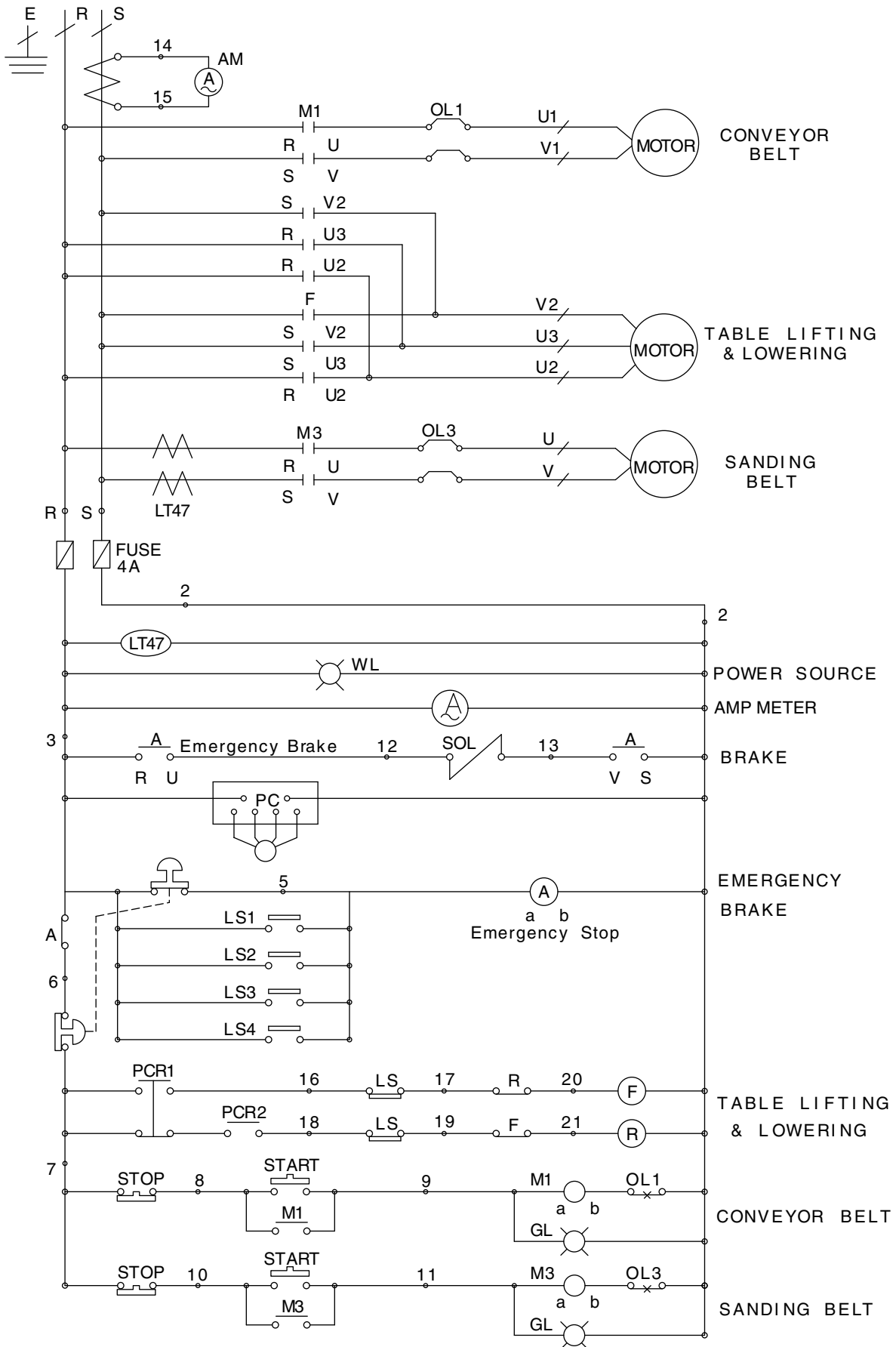



*Replaces Page 63*

# Upper Roller System Parts List

REF	PART #	DESCRIPTION
6101	P04456101	SQUARE FRAME (G0445)
6101	P9962Z6101	SQUARE FRAME (G9962Z/G9962ZX/G0582)
6103	P04456103	FRAME SEAL (RIGHT) (G0445)
6103	P9962Z6103	FRAME SEAL (RIGHT) (G9962Z/G9962ZX/G0582)
6104	P04456104	FRAME SEAL (LEFT) (G0445)
6104	P9962Z6104	FRAME SEAL (LEFT) (G9962Z/G9962ZX/G0582)
6105	PFH05	FLAT HD SCR 1/4-20 X 3/4
6106	PLW04	LOCK WASHER 3/8
6107	PB18	HEX BOLT 3/8-16 X 1
6108	PLW07	LOCK WASHER 1/2
6109	PCAP78	CAP SCREW 1/2-12 X 1
6111	PCAP07	CAP SCREW 5/16-18 X 3/4
6112	PB09M	HEX BOLT M8-1.25 X 20
6113	P9962Z6113	AIR CYLINDER
6114	P9962Z6114	LIMIT SWITCH HOLDER (L TYPE)
6115	P9962Z6115	LIMIT SWITCH
6115-1	P9962Z6115-1	LIMIT SWITCH
6116	P9962Z6116	LIMIT SWITCH POST
6117	P9962Z6117	LIMIT SWITCH HOLDER
6118	P9962Z6118	AIR SENSOR NOZZLE (FEMALE)
6119	P9962Z6119	AIR CYLINDER BRACKET
6120	P9962Z6120	AIR SENSOR NOZZLE (MALE)
6122	P9962Z6122	THROTTLE VALVE BASE
6123	P9962Z6123	PLATE
6124	P9962Z6124	ALUMINUM DISC
6125	P9962Z6125	OIL CAP
6126	P9962Z6126	ALUMINUM PLATE
6127	PS52M	PHLP HD SCR M4-0.7 X 20

REF	PART #	DESCRIPTION
6128	P9962Z6128	BRACKET
6129	PN11	HEX NUT 3/8-24 (FINE THREAD)
6131	PLW01	LOCK WASHER 5/16
6132	PB07	HEX BOLT 5/16-18 X 3/4
6133	PS08	PHLP HD SCR #10-24 X 3/4
6134	PN07	HEX NUT #10-24
6135	P9962Z6135	OIL CAP CONNECTOR
6136	P9962Z6136	OIL CAP SHAFT
6201	P9962Z6201	UPPER ROLLER BRACKET
6202	P9962Z6202	UPPER ROLLER
6203	P9962Z6203	UPPER ROLLER BRACKET
6204	P9962Z6204	BEARING UCC205
6205	PSS02M	SET SCREW M6-1.0 X 6
6206	PCAP16	CAP SCREW 3/8-16 X 3/4
6207	PLW04	LOCK WASHER 3/8
6208	P9962Z6208	FILTER
6212	PLW04	LOCK WASHER 3/8
6213	PCAP16	CAP SCREW 3/8-16 X 3/4
6301	P9962Z6301	TRIMMING ADJUSTER
6302	P9962Z6302	ECCENTRIC ROD
6303	PCAP79	CAP SCREW 1/2-12 X 3-1/2
6304	PW01	FLAT WASHER 1/2
6305	P9962Z6305	ECCENTRIC PIECE
6306	P9962Z6306	UNIVERSAL JOINT FORK
6310	PN13	HEX NUT 1/2-13
6320	P9962Z6320	ECCENTRIC SHAFT COLLAR
6321	P9962Z6321	VALVE ASSEMBLY
6322	PN02	HEX NUT 5/16-18
6323V2	P9962Z6323V2	OSCILLATION AIR CYLINDER V2.01.14
6324	PB11	HEX BOLT 5/16-18 X 1-1/2
6325	P9962Z9124	CONNECTOR 1/4N X 1/8T X 90°



Replaces Page 68

# Belt Oscillation System Diagram

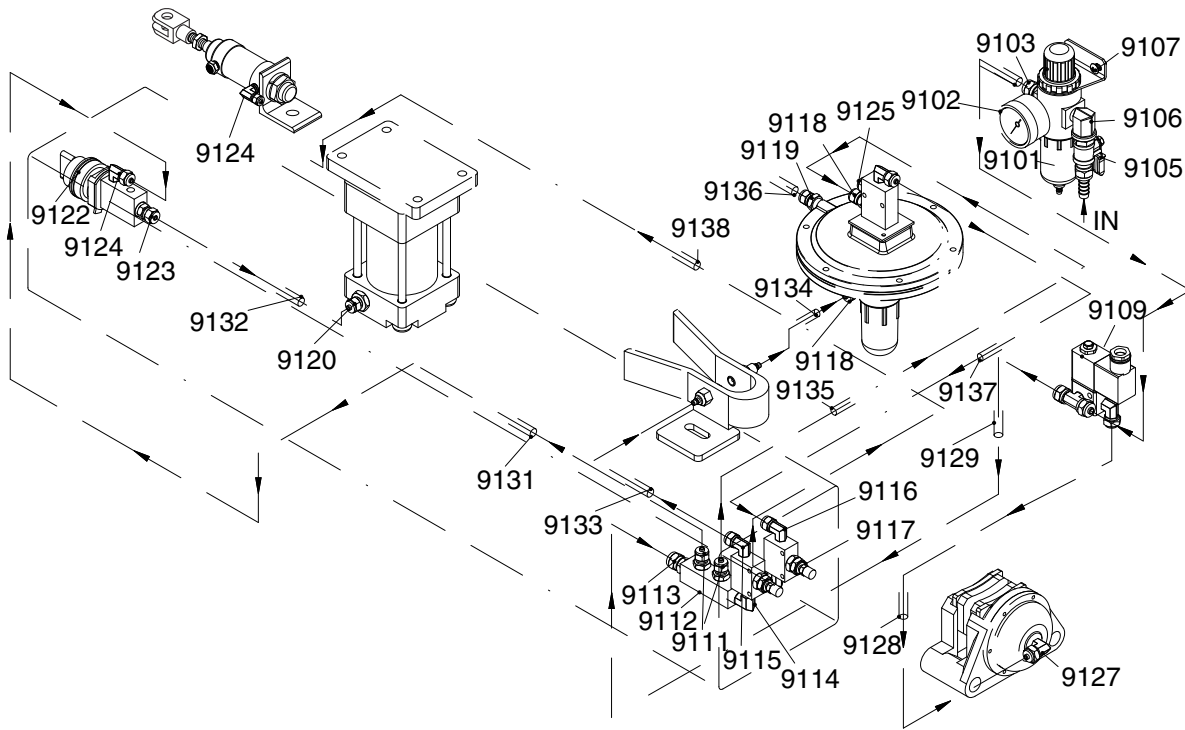

REF	PART #	DESCRIPTION
9101	P9962Z9101	FILTER CUP
9102	P9962Z9102	PRESSURE REGULATOR
9103	P9962Z9103	CONNECTOR, BRONZE
9105	P9962Z9105	AIR SWITCH
9106	P9962Z9106	ELBOW
9107	PS01	PHLP HD SCR 10-24 X 1/2
9109	P9962Z9109	SOLENOID VALVE
9111	P9962Z9111	CONNECTOR, BRONZE
9112	P9962Z9112	AIR MANIFOLD
9113	P9962Z9113	CONNECTOR, BRONZE
9114	P9962Z9114	ELBOW 1/4N X 1/8T X 90°, BRONZE
9115	P9962Z9115	CONNECTOR 1/4N X 1/8T X 90°
9116	P9962Z9116	CONNECTOR 1/4N X 1/8T X 90°
9117	P9962Z9117	THROTTLE VALVE
9118	P9962Z9118	CONNECTOR, BRONZE
9119	P9962Z9119	ELBOW, BRONZE

REF	PART #	DESCRIPTION
9120	P9962Z9120	CONNECTOR 1/4N X 3/8T
9122	P9962Z9122	AIR SWITCH
9123	P9962Z9123	CONNECTOR 1/4N X 1/8T
9124	P9962Z9124	CONNECTOR 1/4N X 1/8T X 90°
9125	P9962Z9125	BUFFER
9127	P9962Z9127	CONNECTOR 5/16N X 1/8T X 90°
9128	P9962Z9128	FLEXIBLE HOSE 8MM
9129	P9962Z9129	FLEXIBLE HOSE 8MM
9131	P9962Z9131	FLEXIBLE HOSE 6MM
9132	P9962Z9132	FLEXIBLE HOSE 6MM
9133	P9962Z9133	FLEXIBLE HOSE 6MM
9134	P9962Z9134	FLEXIBLE HOSE 6MM
9135	P9962Z9135	FLEXIBLE HOSE 6MM
9136	P9962Z9136	FLEXIBLE HOSE 6MM
9137	P9962Z9137	FLEXIBLE HOSE 6MM
9138	P9962Z9138	FLEXIBLE HOSE 6MM



# *grizzly.com*<sup>®</sup>

**TOOL WEBSITE**

Buy Direct and Save with Grizzly<sup>®</sup> – Trusted, Proven and a Great Value!  
~Since 1983~

*Visit Our Website Today For  
Current Specials!*

**ORDER  
24 HOURS A DAY!  
1-800-523-4777**



# *Grizzly* *Industrial, Inc.*®

## **MODEL G0445/G0582/G9962Z/9962ZX 24" WIDE-BELT SANDER INSTRUCTION MANUAL**



COPYRIGHT © OCTOBER 2005 BY GRIZZLY INDUSTRIAL, INC. REVISED JUNE 2006.  
**WARNING: NO PORTION OF THIS MANUAL MAY BE REPRODUCED IN ANY SHAPE  
OR FORM WITHOUT THE WRITTEN APPROVAL OF GRIZZLY INDUSTRIAL, INC.**

#CR7521 PRINTED IN TAIWAN

# WARNING

Some dust created by power sanding, sawing, grinding, drilling, and other construction activities contains chemicals known to the State of California to cause cancer, birth defects or other reproductive harm. Some examples of these chemicals are:

- Lead from lead-based paints.
- Crystalline silica from bricks, cement, and other masonry products.
- Arsenic and chromium from chemically treated lumber.

Your risk from these exposures varies, depending on how often you do this type of work. To reduce your exposure to these chemicals: work in a well ventilated area, and work with approved safety equipment, such as those dust masks that are specially designed to filter out microscopic particles.

# Table of Contents

- INTRODUCTION..... 3**
  - Foreword ..... 3
  - Contact Info ..... 3
  - Control Panel Features ..... 4
  - External Features ..... 4
  - Internal Features ..... 5
  - Machine Data Sheet (G0445) ..... 6
  - Machine Data Sheet (G0582) ..... 7
  - Machine Data Sheet (G9962Z) ..... 8
  - Machine Data Sheet (G9962ZX)..... 9
- SECTION 1: SAFETY ..... 10**
  - Safety Instructions for Machinery ..... 10
  - Additional Safety for Wide Belt Sanders ..... 12
- SECTION 2: CIRCUIT REQUIREMENTS ..... 13**
  - 220V/440V Connection ..... 13
  - Extension Cords ..... 13
  - Grounding..... 13
  - Amperage Loads ..... 13
  - 440V Connection..... 14
  - Clean Up ..... 15
  - Site Considerations ..... 15
- SECTION 3: SETUP ..... 16**
  - Beginning Assembly ..... 16
  - Air Line Installation..... 16
  - Unpacking ..... 16
  - Inventory..... 17
  - Dust Collection ..... 17
  - Sanding Belt ..... 18
  - Pressure Roller Test ..... 19
  - Start Up ..... 19
  - Recommended Adjustments ..... 20
- SECTION 4: OPERATIONS ..... 21**
  - Operation Safety ..... 21
  - Choosing Sandpaper ..... 21
  - Table Movement ..... 22
  - Adjusting Feed Rate..... 22
  - Amp Draw Meter ..... 23
  - Sanding Workpiece ..... 24
  - Platen Adjustment ..... 24
- SECTION 5: ACCESSORIES ..... 25**
- SECTION 6: MAINTENANCE ..... 26**
  - General..... 26
  - Schedule ..... 26
  - Sanding Belts ..... 27
  - Air System..... 27
  - Dust and Water Traps ..... 27
- SECTION 7: SERVICE ..... 28**
  - Table Calibration ..... 28
  - Platen Service ..... 28
  - Brake Service ..... 29



Oscillation Timing .....	30
Oscillation Speed .....	32
Table Parallelism.....	32
Pressure Rollers.....	33
V-Belt Adjustment .....	34
Air System Diagram .....	35
Conveyor Belt Replacement .....	36
Feed Belt Tension.....	38
Feed Belt Tracking.....	38
Maintenance Log.....	39
Troubleshooting.....	40
Tool Box and Accessories Diagram.....	50
Tool Box and Accessories Parts List .....	51
Sanding Motor System Diagram .....	52
Sanding Motor System Parts List.....	53
Table Lift System Diagram.....	54
Table Lift System Parts List .....	55
Conveyor System Diagram .....	56
Conveyor System Parts List.....	57
Feed, Drum, and Pressure Roller Diagram.....	58
G9962Z .....	58
G9962ZX .....	58
G0582.....	58
G0445.....	58
Feed, Drum, and Pressure Roller Parts List.....	59
Sanding Drum and Platen System Diagram .....	60
Sanding Drum, and Platen System Parts List.....	61
Upper Roller System Diagram .....	62
Upper Roller System Parts List.....	63
Cabinet Assembly Diagram.....	64
Cabinet Assembly Parts List .....	65
Main Electrical Panel and Controls Diagram .....	66
Main Electrical Panel and Controls Parts List.....	67
Belt Oscillation System Diagram.....	68
Belt Oscillation System Parts List .....	69
Label Diagram .....	70
Labels List .....	71
Hardware Recognition Chart.....	72
<b>WARRANTY &amp; RETURNS .....</b>	<b>74</b>



# INTRODUCTION

---

---

## Foreword

---

---

We are proud to offer the Model G0445/G0582/G9962Z/9962ZX Wide Belt Sander. This machine is part of the growing Grizzly family of fine wood-working machinery. When used according to the guidelines set forth in this manual, you can expect years of trouble-free, enjoyable operation and proof of Grizzly's commitment to customer satisfaction.

We are pleased to provide this manual with the Model G0445/G0582/G9962Z/9962ZX Wide Belt Sander. It was written to guide you through assembly, review safety considerations, and cover general operating procedures.

The specifications, drawings, and photographs illustrated in this manual represent the Model G0445/G0582/G9962Z/9962ZX Wide Belt Sander as supplied when the manual was prepared. For your convenience, we always keep current Grizzly manuals available on our website at **www.grizzly.com**. Any updates to your machine will be reflected in these manuals as soon as they are complete.

## Contact Info

---

---

If you have any comments regarding this manual, please write to us at the address below:

Grizzly Industrial, Inc.  
c/o Technical Documentation Manager  
P.O. Box 2069  
Bellingham, WA 98227-2069

We stand behind our machines. If you have any service questions or parts requests, please call or write us at the location listed below.

Grizzly Industrial, Inc.  
1203 Lycoming Mall Circle  
Muncy, PA 17756  
Phone: (570) 546-9663  
Fax: (800) 438-5901  
E-Mail: [techsupport@grizzly.com](mailto:techsupport@grizzly.com)  
Web Site: <http://www.grizzly.com>



# Control Panel Features

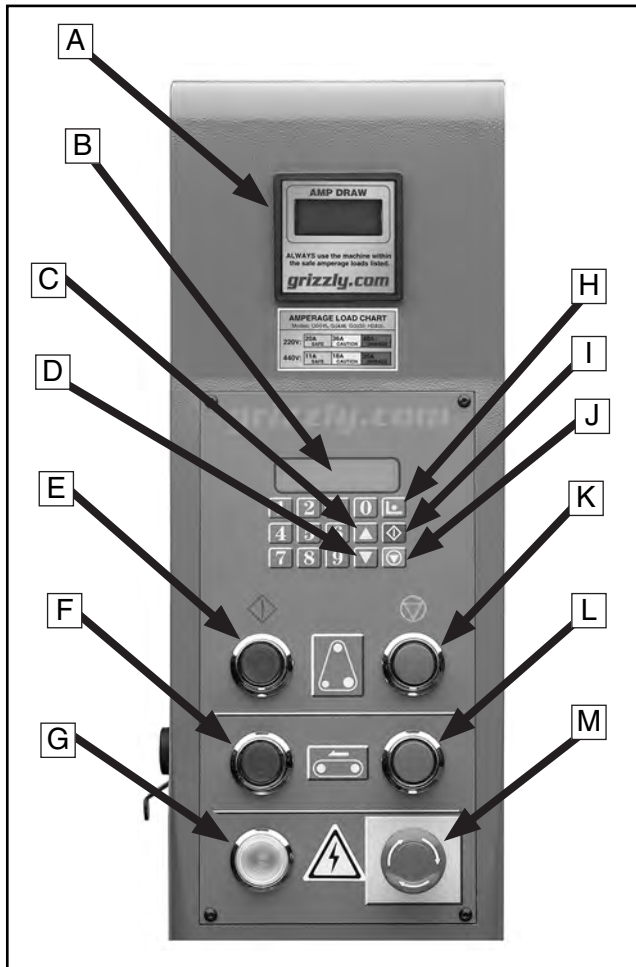

**Figure 1. Control Panel.**

- A. Digital Amp Draw Meter
- B. Table-Height Digital Readout
- C. Table Up Key
- D. Table Down Key
- E. Sanding Belt Start Button
- F. Conveyor Belt Start Button
- G. Power Light
- H. Table Set (Enter) Key
- I. Table Adjustment Start Key
- J. Table Adjustment Stop Key
- K. Sanding Belt Stop Button
- L. Feed Belt Stop Button
- M. Emergency Stop Button

# External Features

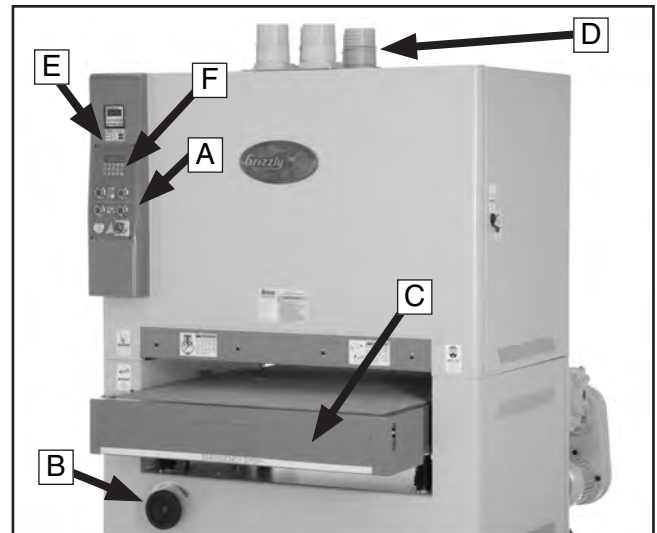

**Figure 2. Front View.**

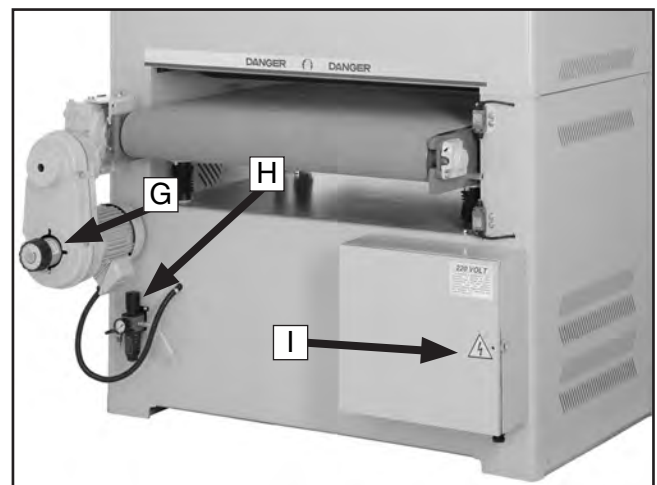
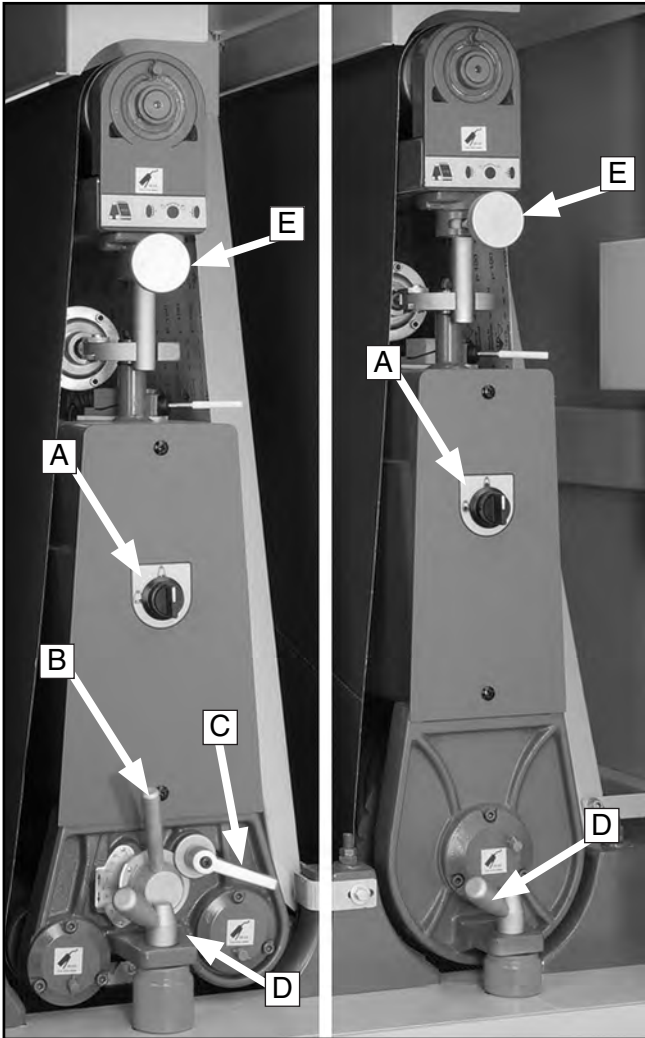

**Figure 3. Rear View.**

- A. Control Panel
- B. Table Height Handwheel
- C. Emergency Stop Push-Panel
- D. 4" Dust Collection Ports
- E. Amperage Load Chart Label
- F. Digital Table Height Key Pad
- G. Conveyor Speed Control
- H. Air Pressure Regulator
- I. Main Wiring Box



# Internal Features



**Figure 4.** Inside the left access door.

- A.** Belt Tension Knob
- B.** Platen Adjustment Lever
- C.** Platen Adjustment Lock Lever
- D.** Lock Post Release Lever
- E.** Tracking Adjustment Knob

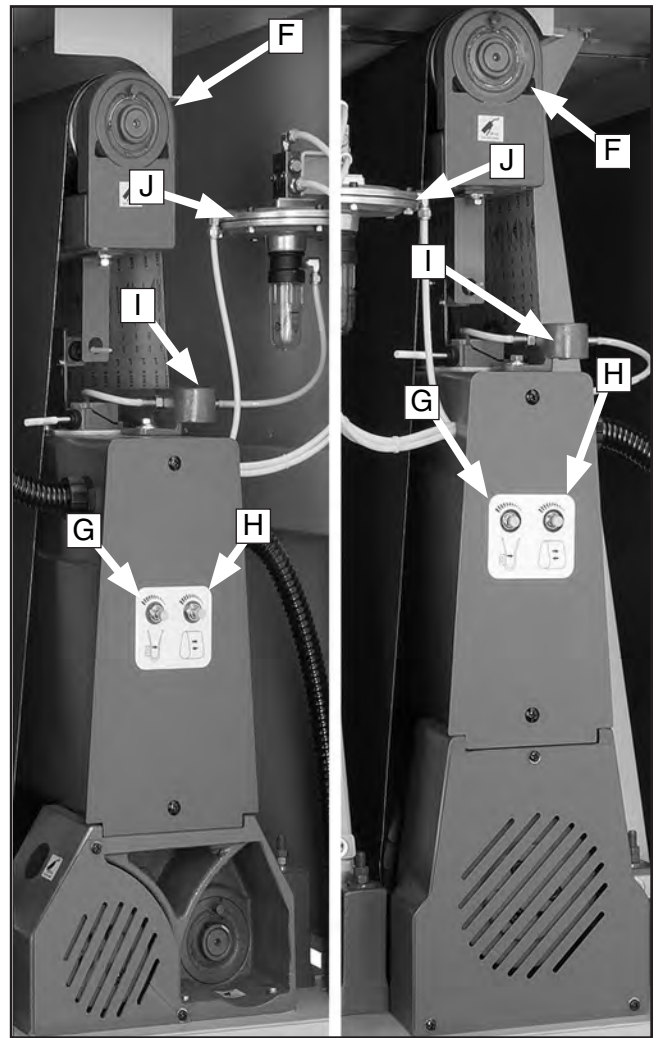

**Figure 5.** Inside the right access door.

- F.** Upper Roller
- G.** Airflow Adjustment Knob
- H.** Speed Control Adjustment Knob
- I.** Air Fork and Air Jet
- J.** Diaphragm Valve Assembly





# MACHINE DATA SHEET

Customer Service #: (570) 546-9663 • To Order Call: (800) 523-4777 • Fax #: (800) 438-5901

## MODEL G0445 TALL 24" WIDE-BELT SANDER

Design Type .....	Floor Model
<b>Overall Dimensions:</b>	
Width .....	42"
Height .....	71½"
Height (With Dust Ports) .....	77½"
Depth .....	40½"
Belt Height.....	50"
Weight (Shipping).....	1984 lbs.
Net Weight .....	1764 lbs.
Approximate Crate Size .....	52" L x 44" W x 74" H
Footprint .....	39¾" x 19⅝"
<b>Capacities:</b>	
Maximum Board Width .....	24"
Maximum Board Thickness.....	6"
Minimum Board Length.....	9"
Minimum Board Thickness.....	⅛"
Surface Speed of Drums.....	2565 FPM
Conveyor Speed .....	14¾-49 FPM
Dust Ports .....	4"
Drum Diameter.....	4"
<b>Sanding Drum Motor:</b>	
Type .....	TEFC Induction
Horsepower .....	10 HP
Voltage / Phase / Cycle.....	220/440V / 3-Phase/60 HZ
..... (440V Operation Requires Purchasing 440V Internal Switching Components)	
Amps .....	25/12.5A
RPM .....	1725 RPM
Power Transfer to Drums.....	Triple V-Belt
<b>Conveyor Feed Motor:</b>	
Type .....	TEFC Induction
Horsepower .....	1 HP
Voltage / Phase / Cycle.....	220/440V / 3-Phase / 60 HZ
..... (440V Operation Requires Purchasing 440V Internal Switching Components)	
Amps .....	3.4/1.7A
RPM .....	1725 RPM
Power Transfer.....	Belt
<b>Table Lift Motor:</b>	
Type .....	TEFC Induction
Horsepower.....	¼ HP
Voltage / Phase / Cycle.....	220/440V / 3-Phase / 60 HZ
..... (440V Operation Requires Purchasing 440V Internal Switching Components)	
Amps .....	1.2/0.6A
RPM .....	1725 RPM
Power Transfer.....	Belt
<b>General Construction:</b>	
Cabinet.....	Steel
Sanding Belt Oscillation .....	⅝-¾" Adjustable
Sanding Belt Brake .....	Disc
Control Panel .....	Push Button For Each Motor, Including Load Indicator
Sanding Method.....	Drum and Platen Type
.....	Requires Sanding Belts 25" x 75"





# MACHINE DATA SHEET

Customer Service #: (570) 546-9663 • To Order Call: (800) 523-4777 • Fax #: (800) 438-5901

## MODEL G0582 24" WIDE-BELT SANDER

Design Type ..... Floor Model

### Overall Dimensions:

Width ..... 42"  
 Height ..... 64"  
 Depth ..... 50"  
 Belt Height ..... 32"  
 Weight (Shipping) ..... 1870 lbs.  
 Net Weight ..... 1650 lbs.  
 Approximate Crate Size ..... 52" L x 44" W x 74" H  
 Footprint ..... 39<sup>3</sup>/<sub>8</sub>" x 19<sup>5</sup>/<sub>16</sub>"

### Capacities:

Maximum Board Width ..... 24<sup>3</sup>/<sub>8</sub>"  
 Maximum Board Thickness ..... 6"  
 Minimum Board Length ..... 14"  
 Minimum Board Thickness ..... 1/8"  
 Surface Speed of Drums ..... 2565 FPM  
 Conveyor Speed ..... 15-49 FPM  
 Dust Ports (2) ..... 4"

### Sanding Drum Motor:

Type ..... TEFC Induction  
 Horsepower ..... 10 HP  
 Voltage / Phase / Cycle ..... 220/440V / 3-Phase/60 HZ  
 ..... (440V Operation Requires Purchasing 440V Internal Switching Components)  
 Amps ..... 25/12.5A  
 RPM ..... 1725 RPM  
 Power Transfer to Drums ..... Belt

### Conveyor Feed Motor:

Type ..... TEFC Induction  
 Horsepower ..... 1 HP  
 Voltage / Phase / Cycle ..... 220/440V / 3-Phase / 60 HZ  
 ..... (440V Operation Requires Purchasing 440V Internal Switching Components)  
 Amps ..... 3.4/1.7A  
 RPM ..... 1725 RPM  
 Power Transfer ..... Belt

### Table Lift Motor:

Type ..... TEFC Induction  
 Horsepower ..... 1/4 HP  
 Voltage / Phase / Cycle ..... 220/440V / 3-Phase / 60 HZ  
 ..... (440V Operation Requires Purchasing 440V Internal Switching Components)  
 Amps ..... 1.2/0.6A  
 RPM ..... 1725 RPM  
 Power Transfer ..... Belt

### General Construction:

Cabinet ..... Steel  
 Sanding Belt Oscillation ..... 5/8 - 3/4" Adjustable  
 Sanding Belt Brake ..... Disc  
 Control Panel ..... Push Button For Each Motor, Including Load Indicator  
 Sanding Method ..... Drum and Platen Type  
 ..... Requires Sanding Belts 25" x 60"

*Specifications, while deemed accurate, are not guaranteed.*





# MACHINE DATA SHEET

Customer Service #: (570) 546-9663 • To Order Call: (800) 523-4777 • Fax #: (800) 438-5901

## MODEL G9962Z 24" WIDE-BELT SANDER

Design Type ..... Floor Model

### Overall Dimensions:

Width ..... 39<sup>5</sup>/<sub>8</sub>"  
 Height ..... 72"  
 Depth ..... 50"  
 Belt Height ..... 30"  
 Weight (Shipping) ..... 1870 lbs.  
 Net Weight ..... 1650 lbs.  
 Approximate Crate Size ..... 52" L x 44" W x 74" H  
 Footprint ..... 39<sup>5</sup>/<sub>8</sub>" x 19<sup>1</sup>/<sub>16</sub>"

### Capacities:

Maximum Board Width ..... 24<sup>3</sup>/<sub>8</sub>"  
 Maximum Board Thickness ..... 6"  
 Minimum Board Length ..... 10"  
 Minimum Board Thickness ..... 1/8"  
 Surface Speed of Drums ..... 3500 FPM  
 Conveyor Speed ..... 15-49 FPM  
 Dust Ports (2) ..... 4"

### Sanding Drum Motor:

Type ..... TEFC Capacitor Start Induction  
 Horsepower ..... 10 HP  
 Voltage / Phase / Cycle ..... 220V / Single-Phase / 60 HZ  
 Amps ..... 50  
 RPM ..... 1725 RPM  
 Power Transfer to Drums ..... Belt

### Conveyor Feed Motor:

Type ..... TEFC Capacitor Start Induction  
 Horsepower ..... 1 HP  
 Voltage / Phase / Cycle ..... 220 / Single-Phase / 60 HZ  
 Amps ..... 7A  
 RPM ..... 1725  
 Power Transfer ..... Belt

### Table Lift Motor:

Type ..... TEFC Capacitor Start Induction  
 Horsepower ..... 1/8 HP  
 Voltage / Phase / Cycle ..... 220V / Single-Phase / 60 HZ  
 Amps ..... 3A  
 RPM ..... 1725  
 Power Transfer ..... Belt

### General Construction:

Cabinet ..... Steel  
 Sanding Belt Oscillation ..... 5/8 - 3/4" Adjustable  
 Sanding Belt Brake ..... Disc  
 Control Panel ..... Push Button for each motor, plus load sensor  
 Sanding Method ..... Single Drum  
 ..... Requires Sanding Belts 25" x 60"

*Specifications, while deemed accurate, are not guaranteed.*





# MACHINE DATA SHEET

Customer Service #: (570) 546-9663 • To Order Call: (800) 523-4777 • Fax #: (800) 438-5901

## MODEL G9962ZX 24" WIDE-BELT SANDER

Design Type ..... Floor Model

### Overall Dimensions:

Width ..... 39<sup>3</sup>/<sub>8</sub>"  
 Height ..... 72"  
 Depth ..... 50"  
 Belt Height ..... 30"  
 Weight (Shipping) ..... 1870 lbs.  
 Net Weight ..... 1650 lbs.  
 Approximate Crate Size ..... 52" L x 44" W x 74" H  
 Footprint ..... 39<sup>3</sup>/<sub>8</sub>" x 19<sup>5</sup>/<sub>16</sub>"

### Capacities:

Maximum Board Width ..... 24<sup>3</sup>/<sub>8</sub>"  
 Maximum Board Thickness ..... 6"  
 Minimum Board Length ..... 10"  
 Minimum Board Thickness ..... 1/8"  
 Surface Speed of Drums ..... 3500 FPM  
 Conveyor Speed ..... 15-49 FPM  
 Dust Ports (2) ..... 4"

### Sanding Drum Motor:

Type ..... TEFC Induction  
 Horsepower ..... 10 HP  
 Voltage / Phase / Cycle ..... 220/440V / 3-Phase/60 HZ  
 ..... (440V Operation Requires Purchasing 440V Internal Switching Components)  
 Amps ..... 25/12.5A  
 RPM ..... 1725 RPM  
 Power Transfer to Drums ..... Belt

### Conveyor Feed Motor:

Type ..... TEFC Induction  
 Horsepower ..... 1 HP  
 Voltage / Phase / Cycle ..... 220/440V / 3-Phase / 60 HZ  
 ..... (440V Operation Requires Purchasing 440V Internal Switching Components)  
 Amps ..... 3.4/1.7A  
 RPM ..... 1725 RPM  
 Power Transfer ..... Belt

### Table Lift Motor:

Type ..... TEFC Induction  
 Horsepower ..... 1/4 HP  
 Voltage / Phase / Cycle ..... 220/440V / 3-Phase / 60 HZ  
 ..... (440V Operation Requires Purchasing 440V Internal Switching Components)  
 Amps ..... 1.2/0.6A  
 RPM ..... 1725 RPM  
 Power Transfer ..... Belt

### General Construction:

Cabinet ..... Steel  
 Sanding Belt Oscillation ..... 5/8" - 3/4" Adjustable  
 Sanding Belt Brake ..... Disc  
 Control Panel ..... Push Button For Each Motor, Including Load Indicator  
 Sanding Method ..... Single Drum  
 ..... Requires Sanding Belts 25" x 60"

*Specifications, while deemed accurate, are not guaranteed.*



# SECTION 1: SAFETY

## WARNING

### For Your Own Safety, Read Instruction Manual Before Operating this Machine

The purpose of safety symbols is to attract your attention to possible hazardous conditions. This manual uses a series of symbols and signal words which are intended to convey the level of importance of the safety messages. The progression of symbols is described below. Remember that safety messages by themselves do not eliminate danger and are not a substitute for proper accident prevention measures.

 **DANGER** Indicates an imminently hazardous situation which, if not avoided, **WILL** result in death or serious injury.

 **WARNING** Indicates a potentially hazardous situation which, if not avoided, **COULD** result in death or serious injury.

 **CAUTION** Indicates a potentially hazardous situation which, if not avoided, **MAY** result in minor or moderate injury. It may also be used to alert against unsafe practices.

**NOTICE** This symbol is used to alert the user to useful information about proper operation of the machine.

## WARNING

### Safety Instructions for Machinery

- 1. READ THROUGH THE ENTIRE MANUAL BEFORE STARTING MACHINERY.** Machinery presents serious injury hazards to untrained users.
- 2. ALWAYS USE ANSI APPROVED SAFETY GLASSES WHEN OPERATING MACHINERY.** Everyday eyeglasses only have impact resistant lenses, they are NOT safety glasses.
- 3. ALWAYS WEAR AN ANSI APPROVED RESPIRATOR WHEN OPERATING MACHINERY THAT PRODUCES DUST.** Wood dust is a carcinogen and can cause cancer and severe respiratory illnesses.
- 4. ALWAYS USE HEARING PROTECTION WHEN OPERATING MACHINERY.** Machinery noise can cause permanent hearing damage.
- 5. WEAR PROPER APPAREL. DO NOT** wear loose clothing, gloves, neckties, rings, or jewelry which may get caught in moving parts. Wear protective hair covering to contain long hair and wear non-pad footwear.
- 6. NEVER OPERATE MACHINERY WHEN TIRED, OR UNDER THE INFLUENCE OF DRUGS OR ALCOHOL.** Be mentally alert at all times when running machinery.



# WARNING

## Safety Instructions for Machinery

7. **ONLY ALLOW TRAINED AND PROPERLY SUPERVISED PERSONNEL TO OPERATE MACHINERY.** Make sure operation instructions are safe and clearly understood.
8. **KEEP CHILDREN AND VISITORS AWAY.** Keep all children and visitors a safe distance from the work area.
9. **MAKE WORKSHOP CHILD PROOF.** Use padlocks, master switches, and remove start switch keys.
10. **NEVER LEAVE WHEN MACHINE IS RUNNING.** Turn power **OFF** and allow all moving parts to come to a complete stop before leaving machine unattended.
11. **DO NOT USE IN DANGEROUS ENVIRONMENTS.** DO NOT use machinery in damp, wet locations, or where any flammable or noxious fumes may exist.
12. **KEEP WORK AREA CLEAN AND WELL LIT.** Clutter and dark shadows may cause accidents.
13. **USE A GROUNDED EXTENSION CORD RATED FOR THE MACHINE AMPERAGE.** Undersized cords overheat and lose power. Replace extension cords if they become damaged. DO NOT use extension cords for 220V machinery.
14. **ALWAYS DISCONNECT FROM POWER SOURCE BEFORE SERVICING MACHINERY.** Make sure switch is in OFF position before reconnecting.
15. **MAINTAIN MACHINERY WITH CARE.** Keep blades sharp and clean for best and safest performance. Follow instructions for lubricating and changing accessories.
16. **MAKE SURE GUARDS ARE IN PLACE AND WORK CORRECTLY BEFORE USING MACHINERY.**
17. **REMOVE ADJUSTING KEYS AND WRENCHES.** Make a habit of checking for keys and adjusting wrenches before turning machinery **ON**.
18. **CHECK FOR DAMAGED PARTS BEFORE USING MACHINERY.** Check for binding and alignment of parts, broken parts, part mounting, loose bolts, and any other conditions that may affect machine operation. Repair or replace damaged parts.
19. **USE RECOMMENDED ACCESSORIES.** Refer to the instruction manual for recommended accessories. The use of improper accessories may cause risk of injury.
20. **DO NOT FORCE MACHINERY.** Work at the speed for which the machine or accessory was designed.
21. **SECURE WORKPIECE.** Use clamps or a vise to hold the workpiece when practical. A secured workpiece protects your hands and frees both hands to operate the machine.
22. **DO NOT OVERREACH.** Keep proper footing and balance at all times.
23. **MANY MACHINES WILL EJECT THE WORKPIECE TOWARD THE OPERATOR.** Know and avoid conditions that cause the workpiece to "kickback."
24. **ALWAYS LOCK MOBILE BASES (IF USED) BEFORE OPERATING MACHINERY.**
25. **BE AWARE THAT CERTAIN WOODS MAY CAUSE AN ALLERGIC REACTION** in people and animals, especially when exposed to fine dust. Make sure you know what type of wood dust you will be exposed to and always wear an approved respirator.



## **WARNING**

# Additional Safety for Wide Belt Sanders

- 1. INFEED/OUTFEED AREA.** When feeding the workpiece into the machine, keep clear of kickback path.
- 2. WORKPIECE FEEDING.** Never force the workpiece into the sander, and feed only one workpiece at a time.
- 3. CLOTHING.** Roll up or button sleeves, tie all loose clothing or hair so it will keep clear of entanglement hazards.
- 4. NARROW WORKPIECES.** Never sand workpieces narrower than  $\frac{1}{8}$ ".
- 5. THIN WORKPIECES.** Never sand workpieces thinner than  $\frac{1}{8}$ ".
- 6. SHORT WORKPIECES.** Never sand workpieces shorter than 14".
- 7. HANDS.** Never place hands near, or in contact with, sanding drums or conveyor belt during operation.
- 8. MAINTENANCE.** Perform machine inspections and maintenance service at the appropriate time intervals.
- 9. POWER AND AIR DISCONNECT.** Unless specifically stated in the manual, always disconnect the power source and air from the machine when performing maintenance, adjustments, or assembly. Always read and follow specific safety instructions for each section.
- 10. UNATTENDED MACHINE.** Never leave the machine running unattended.
- 11. SANDPAPER.** Replace sanding belt when it becomes worn or damaged.
- 12. FOREIGN MATERIAL.** Always inspect workpiece for nails, staples, knots, and other imperfections that could be dislodged and thrown from the machine during sanding operations.
- 13. DUST COLLECTION.** Never operate the sander without an adequate dust collection system in place and running.
- 14. ALLERGIES.** Certain woods may cause an allergic reaction in people and animals, especially when exposed to fine dust. Make sure you know what type of wood dust you will be exposed to and always wear an approved respirator.
- 15. ACCESS DOORS.** Never perform sanding operations when the side access doors are open.
- 16. UNDERSTAND INSTRUCTIONS.** Never allow unsupervised or untrained personnel to operate the machine. Make sure any instructions you give in regards to machine operation are approved, correct, safe, and clearly understood.

## **WARNING**

Unfamiliarity with this manual could result in serious personal injury. Spend a sufficient amount of time becoming familiar with the contents of this manual, including all the safety warnings.

## **WARNING**

No list of safety guidelines can be complete. Operating this machinery may require additional safety precautions specific to your shop environment. Failure to use reasonable caution while operating this machine could result in serious personal injury.



# SECTION 2: CIRCUIT REQUIREMENTS

## 220V/440V Connection

Hard wire this machine to a power panel that can safely supply power to your machine, that has the proper overload protection, and has a locking shut-off lever (**Figure 6**). If you are unsure about electrical wiring, consult a qualified electrician before attempting any wiring.

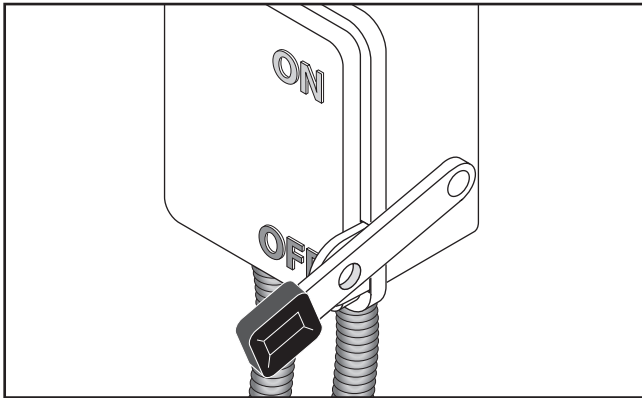

**Figure 6.** Locking Shut-Off Lever.

## Extension Cords

Do not use an extension cord with 220V/440V machinery. An extension cord increases the risk of electrocution and fire. Instead, position your equipment near the power supply to eliminate the extension cord requirement.

## Grounding

	<p><b>⚠️ WARNING</b></p> <p>Electrocution or fire may result if machinery is incorrectly grounded or the power supply violates local and state codes. Contact a qualified electrician for safe wiring practices!</p>
--	--

## Amperage Loads

The following list outlines the electrical phase and voltage required to operate the various sander models, as well as the amperage draw of their motors. **Note:** *If you do not have three-phase power available, you will have to install a phase converter such as the Grizzly Phase Converter.*

### Amperage Draw Specifications:

#### G9962Z—220V, Single-Phase ~60 Amp

10 HP Sanding Motor.....	50 Amps
1 HP Feed Motor.....	7 Amps
1/3 HP Table Motor.....	3 Amps

#### G9962ZX—220V, Three-Phase ~30 Amp

10 HP Sanding Motor.....	25 Amps
1 HP Feed Motor.....	3.4 Amps
1/4 HP Table Motor.....	1.2 Amps

#### G9962ZX—440V, Three-Phase ~15 Amp

10 HP Sanding Motor.....	12.5 Amps
1 HP Feed Motor.....	1.7 Amps
1/4 HP Table Motor.....	0.6 Amp

#### G0582—220V, Three-Phase ~30 Amp

10 HP Sanding Motor.....	25 Amps
1 HP Feed Motor.....	3.4 Amps
1/4 HP Table Motor.....	1.2 Amps

#### G0582—440V, Three-Phase ~15 Amp

10 HP Sanding Motor.....	12.5 Amps
1 HP Feed Motor.....	1.7 Amps
1/4 HP Table Motor.....	0.6 Amp

#### G0445—220V, Three-Phase ~30 Amp

10 HP Sanding Motor.....	25 Amps
1 HP Feed Motor.....	3.4 Amps
1/4 HP Table Motor.....	1.2 Amps

#### G0445—440V, Three-Phase ~15 Amp

10 HP Sanding Motor.....	12.5 Amps
1 HP Feed Motor.....	1.7 Amps
1/4 HP Table Motor.....	0.6 Amp



# 440V Connection

To connect this machine to 440V three-phase, you must purchase two overload relays. Each machine model may require unique relays, so refer to **440V Conversion Relays** on **Page 65** for the relay part numbers.

If you do not have three-phase power available for your wide belt sander, you must install a phase converter such as a Grizzly Phase Converter.

**Note:** When using a phase converter, the power from the manufactured power leg (sometimes called the wild wire) can fluctuate. Connect the manufactured power leg to the S terminal to prevent damage to the transformer. The wire from the S terminal can handle some fluctuation because it goes directly to the motor. The power going to the R and T terminals goes to the transformer and must be consistent to prevent damage.

## To wire the sander to 440V:

1. DISCONNECT THE SANDER FROM THE POWER SOURCE!
2. Open the electrical box located on the back of the machine.
3. On the transformer, remove the wire labeled "1" connected to the 220V terminal for your model of sander, and connect it to the 440V terminal as shown in **Figure 7**.

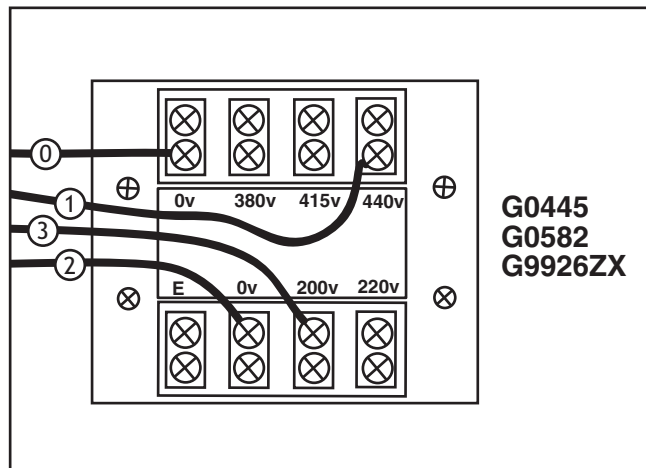

**Figure 7.** 440V transformer connection.

4. Swap out the applicable thermal relay at the locations shown in **Figure 8**, and set it to the overload values listed.

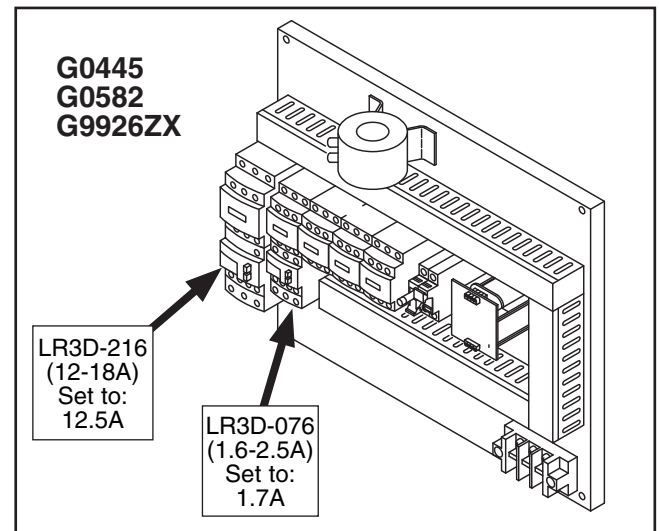

**Figure 8.** Overload relays.

5. Wire the sanding belt, conveyor belt, and table elevation motors as shown on the diagrams on the inside of each motor wire cover, or refer to **Motor Wiring** on **Page 44**.



# Clean Up

Any unpainted surfaces like the upper drums are coated with a waxy oil to protect them from corrosion during shipment. Remove this protective coating with a solvent cleaner or citrus-based degreaser such as Grizzly's G7895 Degreaser. To clean thoroughly, some parts may need to be removed. **For optimum performance from your machine, make sure you clean all moving parts or sliding contact surfaces that are coated.** Avoid chlorine-based solvents as they may damage painted surfaces should they come in contact.

	<p><b>!WARNING</b> Gasoline and petroleum products have low flash points and could explode if used to clean machinery. <b>DO NOT</b> use gasoline or petroleum products to clean the machinery.</p>
--	---

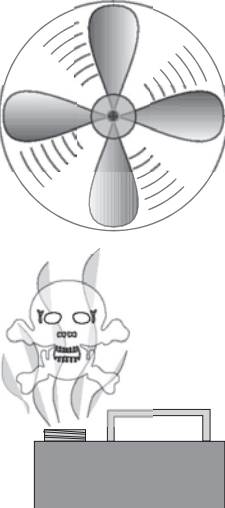
	<p><b>!WARNING</b> Lack of ventilation while using solvents could cause serious personal health risks, fire, or environmental hazards. Always work in a well ventilated area to prevent the accumulation of dangerous fumes. Supply the work area with a constant source of fresh air.</p>
---	--

# Site Considerations

## Floor Load

Refer to the **Machine Data Sheet** for the weight and footprint specifications of your machine. Some shop floors may require additional reinforcement to support both the machine and operator.

## Working Clearance

Working clearances can be thought of as the distances between machines and obstacles that allow safe operation of every machine without limitation. Refer to the **Machine Data Sheet** for the dimensions of your machine. Consider existing and anticipated machine needs, size of material to be processed through each machine, and space for auxiliary stands and/or work tables. Also, consider the relative position of each machine to one another for efficient material handling. Be sure to allow yourself sufficient room to safely run your machines in any foreseeable operation and keep dust collection hoses off the floor and out of the way.

## Lighting

Lighting should be bright enough to eliminate shadows and prevent eye strain. Electrical circuits should be dedicated or large enough to handle combined motor amp loads. Be sure to observe local electrical codes for proper installation of new lighting or circuits.

	<p><b>!WARNING</b> Unsupervised children and visitors entering a shop could suffer serious personal injury. Ensure child and visitor safety by keeping all entrances to the shop locked at all times. <b>DO NOT</b> allow unsupervised children or visitors in the shop at any time.</p>
--	--



# SECTION 3: SETUP

## Beginning Assembly

**Your safety is important!** Complete the assembly in the order provided in this manual. Then read the rest of the manual before attempting any type of sanding operation.

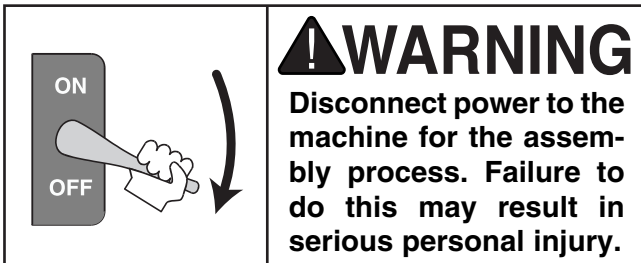

## Air Line Installation

**To install the air line:**

1. Connect the hose from your air compressor to the air inlet (**Figure 9**) on the regulator.

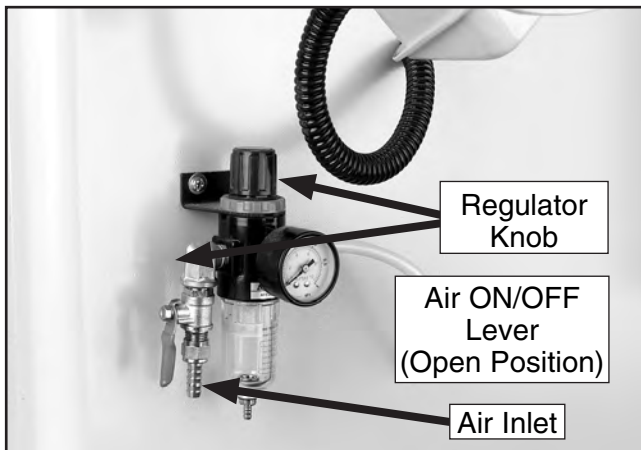

**Figure 9.** Air inlet located on regulator.

2. Move the red handle on the regulator to the open position (parallel with the air inlet).
3. Lift the regulator knob (**Figures 9** and **11**) and turn it until the air pressure gauge reads 75 PSI. **Note:** Turn the knob clockwise to increase the air pressure and counterclockwise to lower the air pressure.
4. Push the regulator knob down until it snaps.

## Unpacking

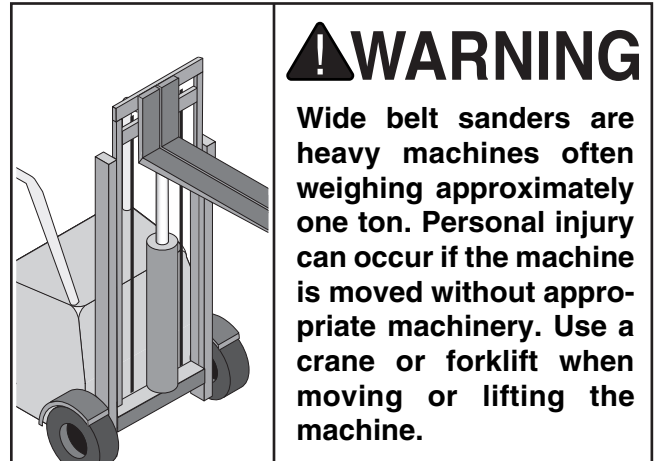

The Model G0445/G0582/G9962Z/G9962ZX was carefully packed when it left our warehouse. If you discover the machine is damaged after you have signed for delivery, *please immediately call Customer Service at (570) 546-9663 for advice.*

Save the containers and all packing materials for possible inspection by the carrier or its agent. *Otherwise, filing a freight claim can be difficult.*

When you are completely satisfied with the condition of your shipment, you should inventory the contents.

## NOTICE

**A parts diagram and parts list are located near the end of the manual. Use the diagram and list to identify missing parts or to supplement the assembly instructions provided in this manual.**



# Inventory

Crate contents, see **Figure 10**.

- A. Sanding Unit (Not Pictured)
- B. (2) Dust Ports 4"
- C. Sanding Belt 100 Grit (G0582/G0445)  
Sanding Belt 100 Grit (G9962Z/G9962ZX)
- D. Sanding Belt 180 Grit (G0582/G0445)  
Sanding Belt 150 Grit (G9962Z/G9962ZX)
- E. (2) Platen Graphite Flap (G0582/G0445)
- F. Platen Felt (G0582/G0445)
- G. Tool Box
  - Phillips Head Screwdriver #2
  - Standard Screwdriver #2
  - Open-End Wrench 8/10mm
  - Open-End Wrench 12/14mm
  - Open-End Wrench 17/19mm
  - Metric Hex Wrench Set 10 Pcs.
  - (2) Door Keys
  - (2) Ceramic Limit Switch Rub Rods
  - (1) Flexible Grease Gun Extension
  - (1) Graphite Holder Bar (G0582/G0445)

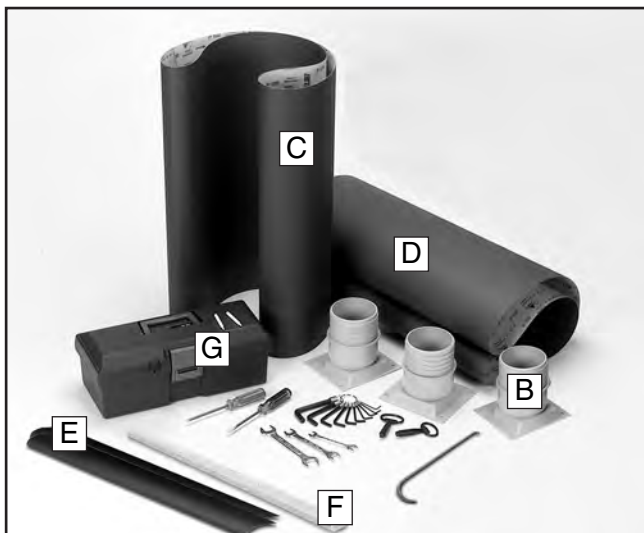

**Figure 10.** Parts layout.

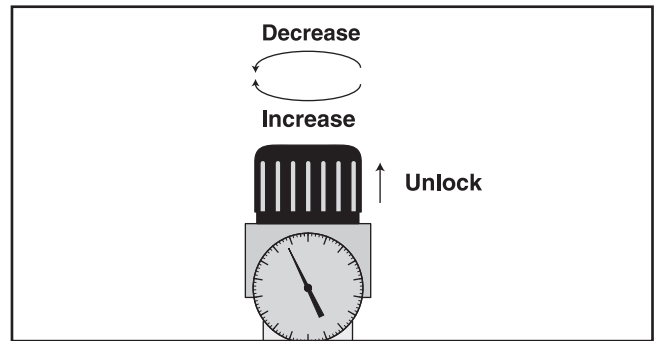

**Figure 11.** Regulator knob.

## Dust Collection

An efficient and clean dust collection system is essential to the proper function of the sander. Ensuring a healthy work environment is also dependent upon cleaning and maintaining your dust collection system. For the G0582/G9962Z/9962ZX we recommend a minimum of 800CFM at the machine, and for the G0445 we recommend a minimum of 1200 CFM at the machine.

**To hook up a dust collection system:**

1. Install the dust ports (**Figure 12**) to the mounting locations on the top of the sanding unit with the supplied M6-1 x 10 Phillips head screws.



**Figure 12.** Typical three-port configuration.

2. Using 4" hose clamps, secure the hoses from your dust collection system to the dust ports.



# Sanding Belt

## To install the sanding belt:

1. DISCONNECT THE SANDER FROM THE POWER SOURCE!
2. De-activate the belt tension piston by turning the belt tension knob (**Figure 13**).
3. Remove the lock post release lever (**Figure 13**) by turning it counterclockwise  $\frac{1}{2}$  turn and pulling it up and out of the mounting hole.
4. Remove the spacer block (**Figure 13**).

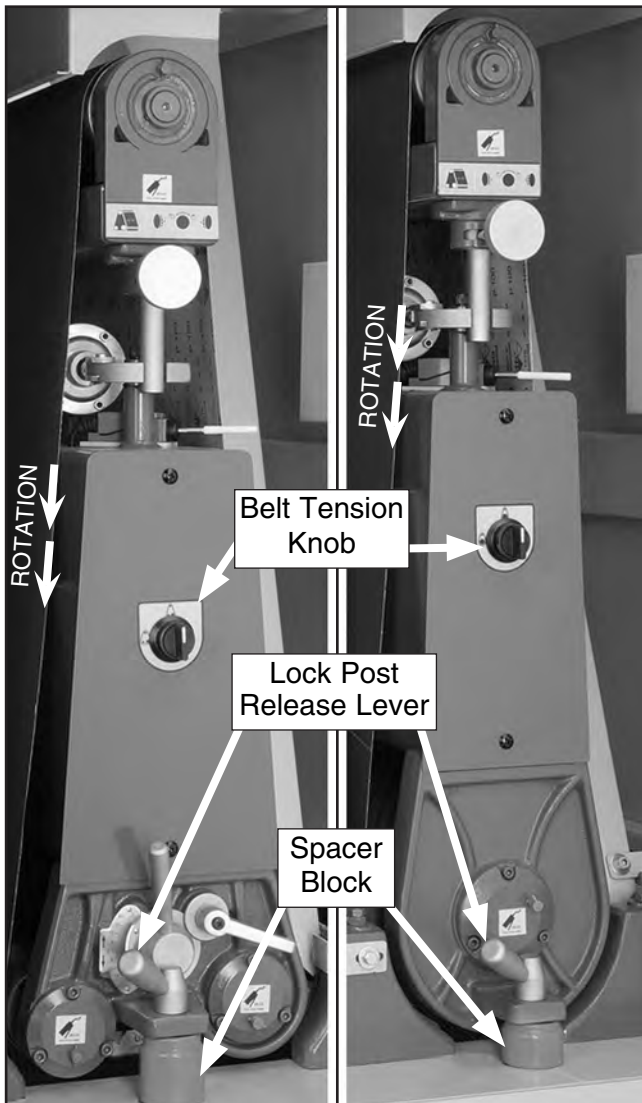

**Figure 13.** Components used when changing a sanding belt on single drum or platen-style wide belt sanders.

5. Making sure the rotation arrows on the sanding belt point the same direction as those shown in **Figure 13**, install the sanding belt by starting first on the upper roller, and then the lower roller.

**Note:** The sanding belt must be centered between the limit switches and the edge of the sanding belt must be between the tongs of the oscillation controller as shown in **Figure 14**. Damage to the sanding belt could occur if the sander is turned **ON** before the sanding belt is correctly positioned.

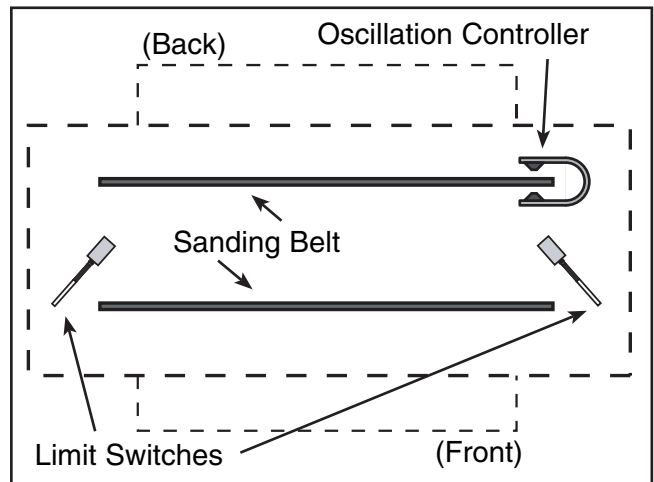

**Figure 14.** Sander Outline (Top View). Proper position of belt between the limit switches.

## **NOTICE**

The directional arrow on the back of the sanding belt must be pointing in a counterclockwise direction during installation. Failure to install the sanding belt correctly could result in damage to the sanding belt or the sander itself.

6. Replace the spacer block and tighten down the lock handle bolt.
7. With your hands clear of all moving parts, tension the belt by turning the belt tension knob.



# Pressure Roller Test

The pressure rollers have been set at the factory, but for your safety, you should verify that they are set below the level of the sanding roller.

## WARNING

It is absolutely essential to keep the pressure rollers set below the level of the sanding roller. If the pressure rollers are even, or higher than the sanding roller, the wood **WILL** be propelled from the sander at a high rate of speed. This situation could cause serious kick-back injury.

### To check the pressure roller height:

1. DISCONNECT THE SANDER FROM THE POWER SOURCE!
2. Place a piece of scrap wood of uniform thickness across the table so it spans both the front and the rear pressure rollers at the same time.
3. With the air pressure connected and the sanding belt installed and tensioned, manually raise the table and verify that the board touches both pressure rollers before it touches the sanding belt.

**Note:** *If the board does not touch both pressure rollers before it touches the sanding belt, then the pressure rollers must be adjusted before operation. Refer to **Pressure Rollers** on **Page 33**.*

# Start Up

## WARNING

Serious personal injury could result if the machine is connected to the power source during assembly or adjustment. Wait until the machine is turned **OFF**, unplugged, and all working parts have come to a complete stop before you attempt to assemble or adjust the machine!

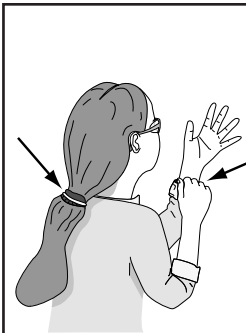

## WARNING

Loose hair and clothing could get caught in machinery causing serious personal injury. Keep loose clothing rolled up and long hair tied up and away from machinery.



## WARNING

Projectiles thrown from the machine could cause serious eye injury. Wear safety glasses during start up.

### Before starting the machine:

1. Read this manual and make sure you take all safety precautions before operating this machine.
2. Make sure the machine is connected to an air compressor and the pressure gauge reads 75 PSI.
3. Make sure all tools or foreign objects have been removed from the conveyor surface, the top of the machine, and the inside of the machine.
4. Make sure all the wiring is correct.



## To start the machine:

1. **Wear safety glasses and respirator at all times when running the machine!**
2. Connect the machine to the power source.
3. Press the TABLE UP and TABLE DOWN keys. The table should go up and down smoothly.

**Note:** *On 3-phase machines, make sure the table moves in the same direction as the button description. If not, then the power needs to be disconnected and any two power wires need to be switched at the circuit breaker in the electrical box. If using a phase converter, switch the R and T wires.*

4. Press the FEED BELT START and FEED BELT STOP buttons. The feed belt should start, run, and stop smoothly.
5. Press the SANDING BELT START and SANDING BELT STOP buttons. The sanding belt should start, run, and stop smoothly.

The machine should run smoothly, with little or no vibration or rubbing noises. Strange or unnatural noises should be investigated and corrected before operating the machine further.

If the machine seems to be running correctly, let it run for a short time to ensure that the moving parts are working properly with no excessive vibration. **DO NOT** operate the machine if problems cannot be corrected.

If you cannot locate the source of unusual noises, refer to **Troubleshooting**, and feel free to contact our Technical Support Department at (570) 546-9663.

# Recommended Adjustments

---

---

For your convenience, the adjustments listed below have been performed at the factory and require no further adjustment. However, we recommend that you verify that the adjustments are correct and to your satisfaction.

## Recommended adjustment checklist:

- Table Calibration, Page 28.
- Feed Belt Tension, Page 38.
- Feed Belt Tracking, Page 38.
- Air System, Page 27.
- Oscillation Timing, Page 30.
- Oscillation Speed, Page 32.
- Pressure Rollers, Page 33.
- Table Parallelism, Page 32.
- V-Belt Adjustment, Page 34.



# SECTION 4: OPERATIONS

## Operation Safety

Your safety is important! Please follow the warnings below during this entire section:

### **WARNING**

To avoid serious personal injury, read and become familiar with the entire instruction manual before using this wide belt sander.

### **WARNING**

Damage to your eyes, lungs, and ears could result from failure to wear safety glasses, a dust mask, and hearing protection while sanding with this machine.

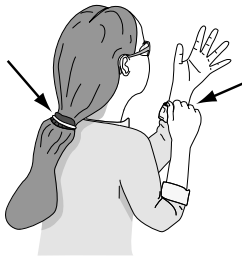

### **WARNING**

Loose hair and clothing could get caught in machinery and cause serious personal injury. Keep loose clothing rolled up and long hair tied up and away from machinery.

## Choosing Sandpaper

The grit you choose will depend on the type of work, the species of wood and the stage of finishing. Below is a chart that groups abrasives into different categories and shows which grits fall into each-one. We recommend using aluminum oxide sanding belts for the best results.

Grit	Type
60	Coarse
80-100	Medium
120-150	Fine

The general rule of thumb is to sand a workpiece with progressively higher grit numbers, with no one grit increase of more than 50; however, the type of wood and desired finish will determine the best grit to use.



# Table Movement

Table height can be adjusted manually or with the digital key pad and motor (see **Figure 15**).

**Manual Table Movement:** Turn the handwheel located under the front of the infeed table for manual table positioning.

**Motorized Table Movement:** Press the TABLE UP or TABLE DOWN key once for motorized table positioning in 0.005" (0.1mm) increments.

**Numerical Key Pad:** Push the keys to enter the sanding depth needed.

**Metric or Standard Key:** Press and hold the SET button for 3 seconds to calibrate display at the current board thickness; or press and hold key for 10 seconds to toggle the display between metric and standard measurement.

**Table Start Key:** Push to move table to a preset sanding depth.

**Table Stop Key:** Push to stop the table movement immediately.

**Digital Display:** Shows final table sanding depth.

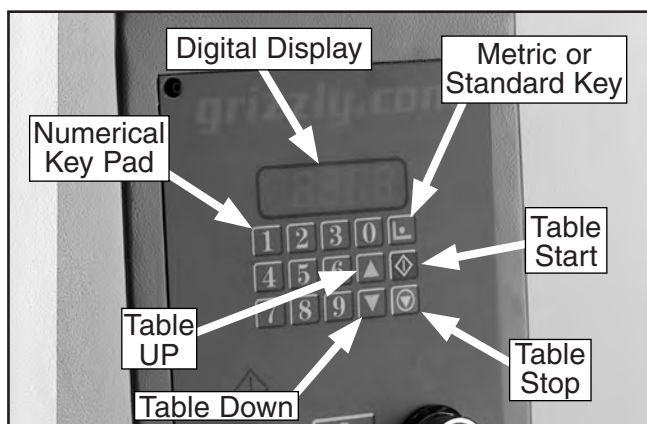

**Figure 15.** Keys for adjusting the table height.

## **NOTICE**

The thickness gauge is pre-calibrated from the factory; however, correct calibration should be verified.

# Adjusting Feed Rate

The dial attached to the side of the feed belt gear box (**Figure 16**) adjusts the feed rate of the sander.

**Note:** *Never adjust the feed rate dial unless the conveyor belt is running, otherwise you can damage the control.*

**Changing Feed Rate:** Turn the dial clockwise to decrease the feed rate and counterclockwise to increase it.

**Determining Ideal Feed Rates:** Softwoods typically require a faster feed rate than hardwoods; however, there is no definitive rule to follow when determining the best feed rate. As a general rule, always start with the slowest feed rate and work your way up. We always recommend testing the feed rate using scrap wood similar to your work-piece. Be sure to monitor the amperage meter when adjusting the feed rate. Decrease the feed rate if the load amperage level shown on the load meter is enters the yellow zone or sanding RPM begins to slow.

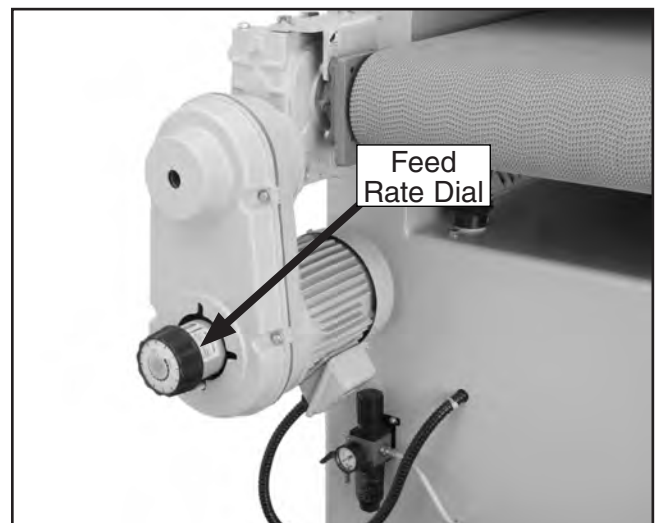

**Figure 16.** Feed rate dial.



# Amp Draw Meter

The amperage draw meter (**Figure 17**) is located above the control panel. Use the meter to monitor the amperage draw on the machine while performing sanding operations.

As a general rule, always start with a small load and work your way up. **DO NOT** work your machine to its maximum load, where you can hear the motor lose RPM; instead, make multiple passes or install a coarser grit paper.

Amp load will be directly affected by many factors such as feed rate, depth of cut, wood type, sandpaper grit, and workpiece width. If the amp load is in the red load range, the machine is overloaded and motor damage will occur. Keep the amp load in the green range during operation.

**NOTICE**  
**DO NOT VOID WARRANTY!** Keep the amp draw within the **GREEN** load range shown on the **AMP LOAD CHART**. If you operate the sander in the **RED** load range, capacitor or motor failure will occur and will not be covered under warranty.



**Figure 17.** Typical amp draw meter and load chart.



# Sanding Workpiece

Typically, no more than 0.5mm (approx.  $\frac{1}{64}$ " ) of material is removed during each pass. Attempts to remove too much material can cause jamming, wood burning, rapid paper wear or tearing, poor finish, short motor life. Make sure that you measure the workpiece thickness before and after every pass.

**The following is the correct sanding operating procedure:**

1. Put on safety glasses, a dust mask, and hearing protection!
2. Turn **ON** the dust collector.
3. On the initial pass, set the table so the sandpaper is 0.25" above the workpiece.

**Note:** *This initial pass setting eliminates the chance of overloading the sander on undetected high points on the workpiece.*

4. Continue to raise the table 0.0625" between each successive pass until the sander begins to sand the workpiece.

## **NOTICE**

**It may be necessary to send wide stock through the sander two or three times between table height adjustments. This reduces the likelihood of burning the wood if there is a high spot.**

# Platen Adjustment

Your sander is equipped with an adjustable felt platen and graphite pad for those extra sensitive sanding operations. The platen position allows for 3 basic types of sanding. These different positions can be adjusted by rotating the height lever shown in **Figure 18**.

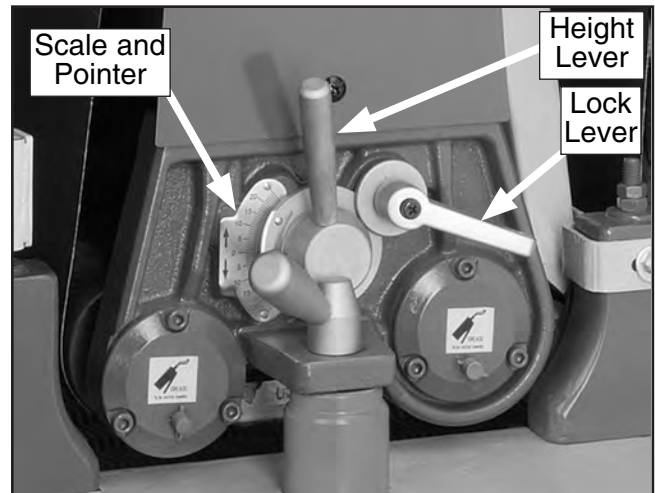

**Figure 18.** Platen height controls.

## **Using the platen:**

For an initial heavy-sanding pass, the platen is raised above the level of the drums, and the table is adjusted to set sanding depth. The drums do all the work using #100 grit or coarser sandpaper, but you will have a rough finish.

For an intermediate-finishing pass, the platen is lowered so it is level with the drums, and the table is adjusted to set sanding depth. The best belt grit for this position is #100-#180.

For a final-sanding pass, do not adjust the table to adjust the sanding depth. The drums must touch the workpiece without doing any sanding. The platen should be lowered to 0.2 to 0.5 mm below the sanding drums. You can lower the platen up to 2 mm below the drums for short intervals, but streaking, burn marks, and premature graphite/platen wear can occur if this setting is abused. The best belt grit for the final-sanding pass is #180 or finer.

**Note:** *The platen scale is broken down in arbitrary increments.*



# SECTION 5: ACCESSORIES

---

---

## Rotary Phase Converter

Add 3-phase, multi-motor capability to your single-phase electrical supply. Operate single or multiple motors, transformers, and resistance loads at 100% power and 95% efficiency while saving big dollars at cheaply metered, single-phase electrical rates. Complete step by step instructions are furnished along with complete wire and fusing requirements for various motor loads. Each model operates up to twice its nameplate rating in a mixed-motor load. See the individual 3-phase machine pages for more phase converter recommendations. For application assistance, please call our technical support at (570) 546-9663.



**Figure 19.** Rotary phase converter.

## H2845 Cleaning Pads

Cleaning pads are the perfect accessory for wide belt sanders. Simply set the conveyor table to height and feed the pad through to “unload” a dirty sanding belt. Regular cleaning greatly increases the lifespan of sanding belts. Check with the current Grizzly catalog or [www.grizzly.com](http://www.grizzly.com) for more details.

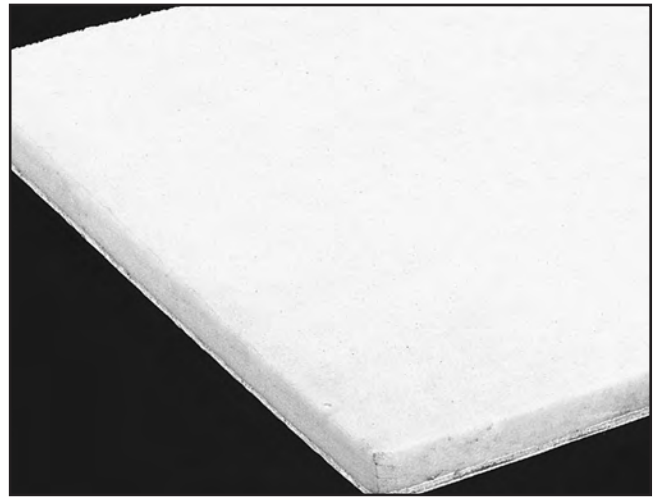

**Figure 20.** Sanding belt cleaning pad.



# SECTION 6: MAINTENANCE

## General

Your safety is important! Please follow the warnings below during this entire section:

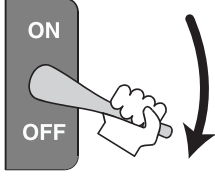
	<p><b>! WARNING</b> Disconnect power to the machine when performing maintenance, assembly or adjustments. Failure to do this may result in serious personal injury.</p>
---	---

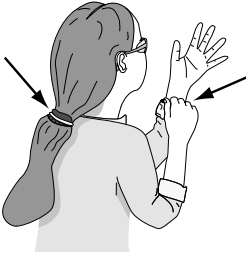
	<p><b>! WARNING</b> Loose hair and clothing could get caught in machinery and cause serious personal injury. Keep loose clothing and long hair away from moving machinery.</p>
--	--

## Schedule

The following items should be checked each time the sander is used:

- Loose mounting bolts.
- Damaged sanding belt.
- Worn or damaged wires.
- Water collection cups filled with water.
- Dust trap.
- Safety features.
- Any other condition that could hamper the safe operation of this machine.

### **NOTICE**

Keep in mind that the service intervals recommended below should occur sooner if the machine is operating under extreme duty or in a dirty shop environment.

#### **Weekly**

Grease the grease fittings located on the feed belt roller axles and the sanding belt roller axles. They are identified with yellow labels.

#### **Monthly**

Apply a generous amount of grease to the table elevation screws. Be sure to recover the adjustment screws with the dust covers when finished.

Remove the lower side panel to access the table lifting mechanism. Apply grease to the chain and gears associated with the table lifting mechanism. Be careful to not get grease on the V-belts. This could cause them to pad off of the pulleys.

#### **After the First 100 Hours**

The oil inside the conveyor gear reducer should be replaced after the first 100 working hours of operation. We recommend 90 Wt. gear oil.

#### **Every 2500 Hours**

After the first conveyor gear reducer oil change, replace the oil after every 2500 working hours of operation. We recommend 90 Wt. gear oil.



# Sanding Belts

You can greatly increase the lifespan of your sanding belts if you clean them often. As mentioned on **Page 25**, cleaning pads are the fastest way to remove saw dust build-up.

## Air System

The air system is durable and reliable; however, components do wear with age. If you suspect that an item in your air system may be having problems, see the air line circuit on **Page 35**.

- Adjust regulator to 75 PSI.
- Carefully inspect all air lines for cracks, tears or hardening. Replace faulty hoses.
- Check the air connections for leaks. A small amount of soapy water in a questionable area will bubble if there is a leak.
- Make sure lines are not clogged. Remove a questionable line and blow through it as a test.

### **CAUTION**

If a component in the air system is malfunctioning, bleed all air from the system, and fix the problem before you resume sanding.

# Dust and Water Traps

There are two traps on this wide belt sander. One water trap is attached to the bottom of the air regulator, and the other trap is attached on the air diaphragm assembly. Cleaning is easy, with the system under air pressure, you can push the lower drain valve and empty regulator water trap (**Figure 21**). Replace the internal white moisture filter yearly. To empty the dust trap bowl, relieve the air pressure and then unscrew and empty the bowl (**Figure 22**). DO NOT allow the water trap or dust bowl to become full.

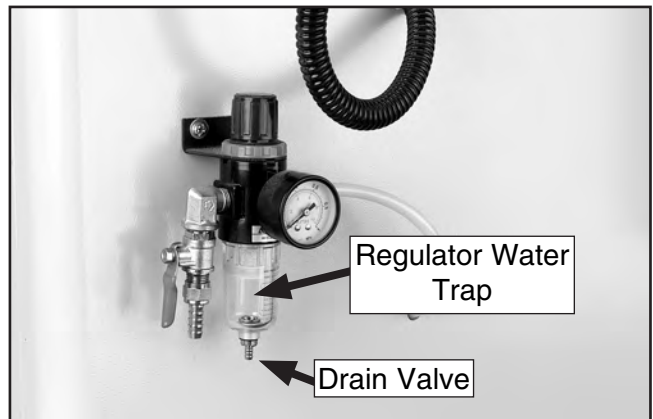

**Figure 21.** Water trap on the regulator.

### **CAUTION**

Bleed all air from the system before you remove the dust bowl, or you may experience a cloud of wood dust.

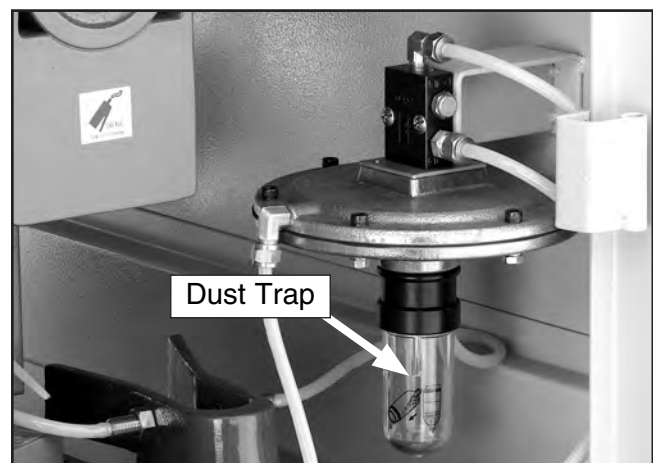

**Figure 22.** Dust trap.



# SECTION 7: SERVICE

## Table Calibration

Use the first board fed through the sander to test the accuracy of the digital thickness gauge.

### To calibrate the digital thickness scale:

1. Using a properly set-up planer, plane a board to uniform thickness.
2. Lower the sander table far enough to place the planed board under the sander roller.
3. Manually raise the table until the board just touches the sanding roller.
4. Remove the board without changing the table height. This ensures the table will be properly adjusted for the first sanding pass.
5. Run the board through the sander several times at the initial height setting. Manually raise the table 0.020" and pass the board through the sander several more times. Monitor the amperage meter and the resulting load on the sander.
6. Measure the thickness at various points around the board using a precise micrometer or set of calipers. Continue sanding the board at that height until the average thickness measurement is within  $\pm 0.003$ ".

**Note:** *These final passes should be done without adjusting the table height. This ensures the most consistent average thickness.*

7. Observe the digital display read-out, it should indicate the average thickness of the sanded wood.

—If it does, the sander is properly calibrated and accurate to the nearest 0.005".

—If it does not, you must recalibrate the digital thickness scale.

### To recalibrate the digital thickness scale:

1. Without moving the table height, enter the numerical measurement of the average thickness of the sanded wood into the digital key pad on the control panel.

**Note:** *The average thickness of the sanded wood should now be flashing on the digital read-out.*

2. Press and hold the  key until the display stops flashing. The sander is now correctly calibrated.

## Platen Service

### To replace the platen felt and graphite pad:

1. DISCONNECT THE SANDER FROM THE POWER SOURCE!
2. Open the left access door, and use the platen tool, shown in **Figure 23**, to remove platen.



**Figure 23.** Removing platen.

3. Replace platen felt pad and graphite pad.
4. Reinsert the platen until it stops.
5. Close the access door.



# Brake Service

Tools Needed:	Qty
14mm Open End Wrench .....	1
Small Snap Ring Pliers .....	1
6mm Hex Wrench.....	1
#2 Phillips Screwdriver .....	1

Eventually the brake pads will wear out. Checking and replacing these is a simple project that can be done in the shop, with the exception of having the rotor resurfaced on a lathe.

## To check the brake pads:

1. DISCONNECT THE SANDER FROM THE POWER SOURCE AND REMOVE AIR PRESSURE COMPLETELY!
2. Remove the four screws that secure the access panel on the right-hand side of the machine.
3. The brake caliper is located underneath the rotor, which is attached to the motor arbor.
4. The brake pads consist of a metal plate with a composite pad. With a fine ruler, measure the thickness of the composite pad only. If one of the pads is below  $\frac{1}{8}$ " (approx. 3mm), replace both.

## To replace the brake pads:

1. DISCONNECT THE SANDER FROM THE POWER SOURCE AND REMOVE AIR PRESSURE COMPLETELY!
2. Remove the nuts from the two mounting bolts and the two snap rings on the mounting pins behind the bracket (see **Figure 24**).

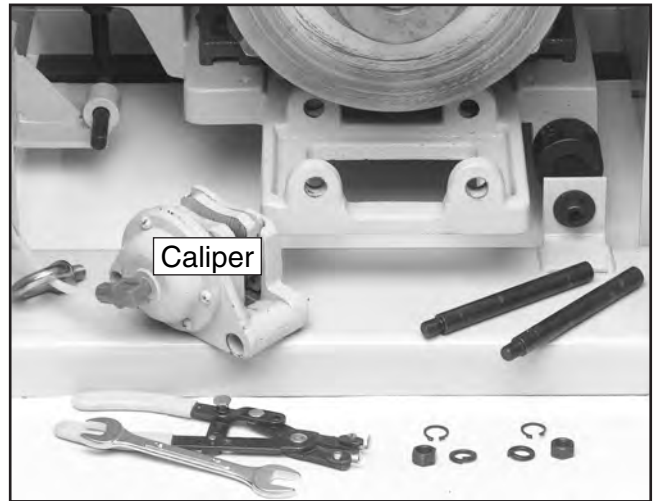

**Figure 24.** Disc brake.

3. Pull the mounting pins out of the caliper bracket and remove the air line from the caliper. The caliper should now be able to be removed.
4. Disassemble the brake caliper and remove the cap screws securing the brake pads.
5. Remove the brake rotor and have it professionally resurfaced at an automotive machine shop if it has gouges in it. If visible cracks are present in the brake rotor, replace it with a new one. Remove oil and dirt from the rotor with automotive brake cleaner. Once clean, only handle the rotor with a dry rag and install exactly the reverse of removal.
6. Install new brake pads, mount the caliper and reconnect the air line.
7. Test the safety shutdown operation by running the sander and pressing the emergency stop controls.



# Oscillation Timing

## **NOTICE**

The oscillation adjustments have been performed at the factory and should require no further attention. However, we recommend verifying the settings.

When the oscillation is correctly adjusted, the sanding belt oscillates to the left and to the right at the same speed. If the sanding belt makes contact with a limit switch, as shown in **Figure 25**, the emergency braking system will activate and stop the sander immediately.

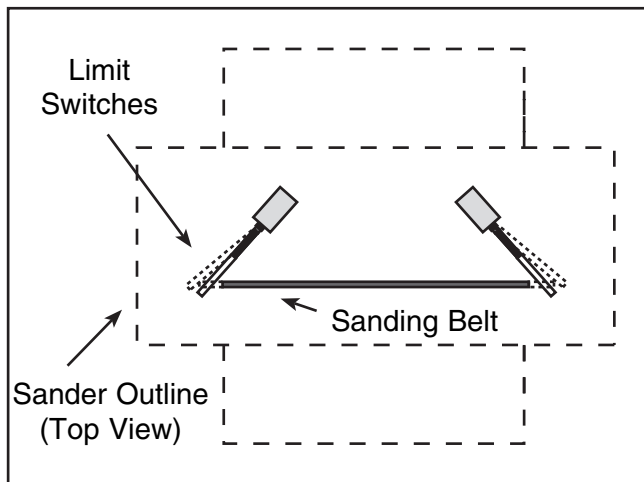
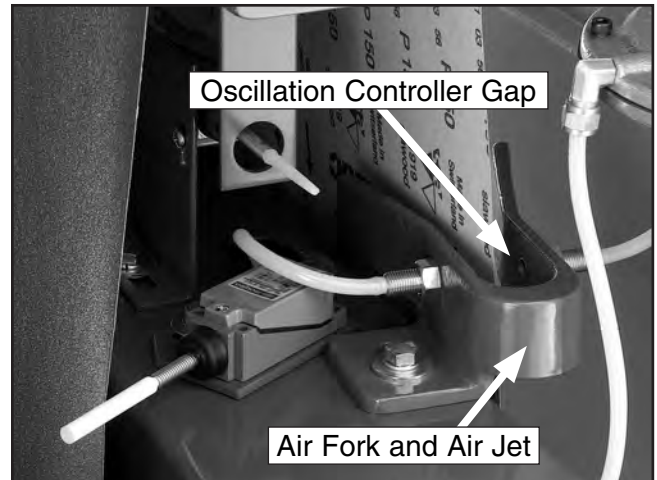

**Figure 25.** Improper oscillation.

### To check the sanding belt oscillation:

1. Be sure the sanding belt is properly installed and the belt tension knob and air supply are **ON**.
2. Turn **ON** the sanding belt.
  - If the belt oscillates without contacting the limit switches, but the oscillation time to the left and right are **NOT** equal, proceed to **Step 7**, on **Page 31**.
  - If the belt tracks away from the air fork and air jet, colliding into the limit switch, continue with **Step 3**.

3. An adequate stream of air through the air fork gap (**Figure 26**) is essential for proper oscillation. If the jet of air is weak through the gap, the belt will track away from the controller and into the limit switch on the opposite end of the roller. The pivot action of the upper roller, and the resulting oscillation of the belt, are dependent upon adequate airflow through the air fork gap.



**Figure 26.** Oscillation components.

### To set the correct amount of airflow through the air fork gap:

1. Remove the sanding belt and turn the belt tension knob to the tensioned position.
2. Loosen the lock nut on the airflow adjustment knob (**Figure 27**).
3. Turn the airflow adjustment knob (**Figure 27**) clockwise until the airflow is completely **OFF**. The upper roller should pivot to the right.
4. Slowly turn the airflow adjustment knob counterclockwise, and continue turning up the air pressure until the roller pivots to the left.

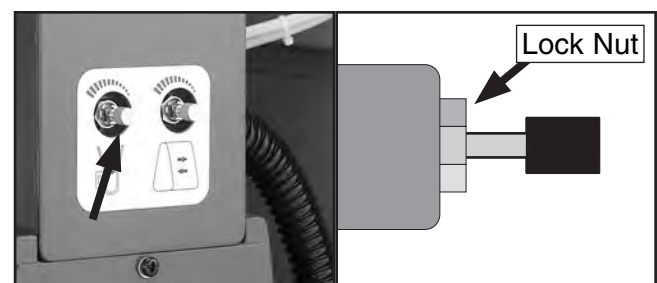

**Figure 27.** Airflow adjustment knob.



5. Tighten the lock nut (**Figure 27**) to secure the airflow adjustment knob.
6. Restrict the airflow across the air fork gap with a scrap piece of wood. You should notice the roller pivot to the right. When the stick is removed, the roller should pivot back to the left.
7. Test the oscillation by running the sander. Make note of the time it takes for the belt to oscillate from left-to-right and from right-to-left.

When correctly timed, the oscillation should take a similar amount of time to oscillate.

- If the oscillation time to the **right** is 2 seconds, but the oscillation time to the **left** is longer, loosen the oscillation adjustment knob (**Figure 28**) and move it to the **left** until proper tracking is achieved. Tighten down the oscillation adjustment knob when satisfied.

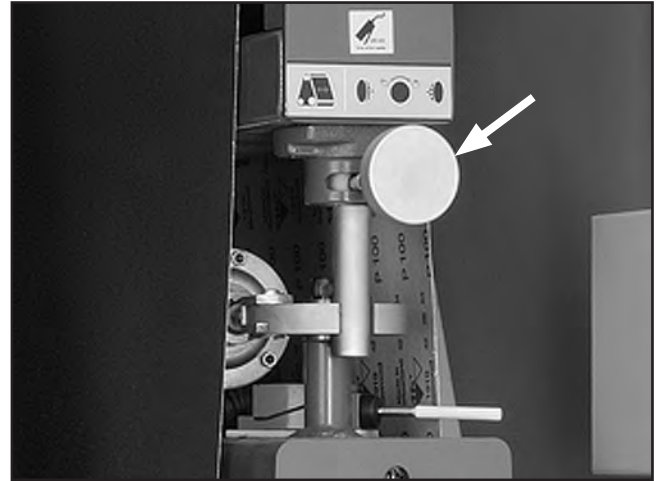

**Figure 28.** Oscillation adjustment knobs.

- If the oscillation time to the **left** is 2 seconds, but the oscillation time to the **right** is longer, loosen the oscillation adjustment knob and move it to the **right** until proper tracking is achieved. Tighten the oscillation adjustment knob when satisfied.
8. Continue to the next page to adjust the oscillation speed.



# Oscillation Speed

The oscillation speed of the sanding belt is adjustable. Different oscillating speeds yield different sanding results. We recommend trying various speeds on a scrap piece of wood similar to the final workpiece.

## To adjust the oscillation speed:

1. Loosen the lock nut on the speed control adjustment knob (**Figure 29**).

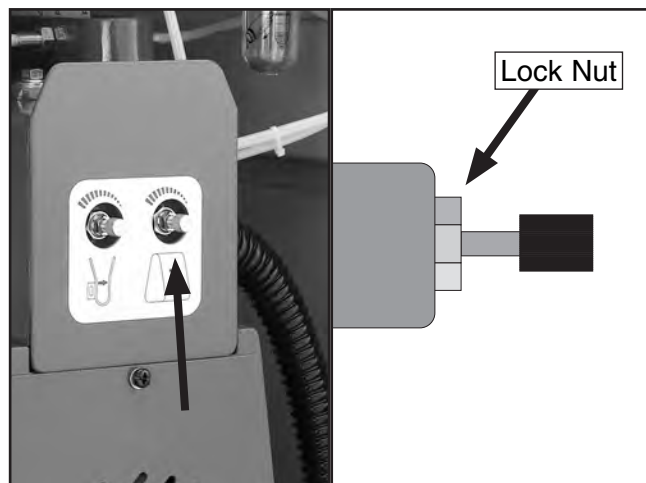

**Figure 29.** Speed control adjustment knob.

2. Turn the knob clockwise to decrease the oscillation speed and counterclockwise to increase it.
3. Tighten the lock nut loosened in **Step 1** to secure the knob.

# Table Parallelism

## **NOTICE**

**The table has been adjusted at the factory and should require no further attention. However, we recommend verifying that it is parallel with the sanding roller.**

The corners of the table can be independently adjusted up or down. Table parallelism can be achieved by disconnecting the chain and turning the pertinent table elevation screw sprocket (**Figure 30**).

Adjusting the table parallelism can be a very tedious task that takes a great amount of patience. DO NOT adjust the table unless you are having trouble sanding your workpiece to a uniform thickness.

If a table adjustment is needed, take precise notes on the positioning of the table elevation screws. This will allow the original setting to be re-established.

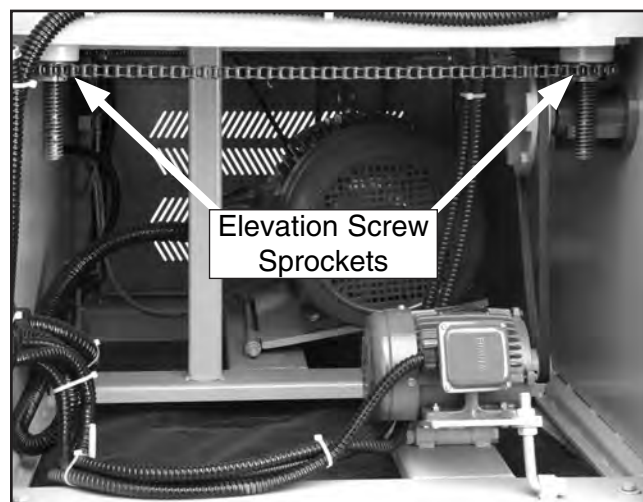

**Figure 30.** View of elevation screw sprockets.



### To adjust the table parallelism:

1. Pass a 24" wide board through the sander until the **entire** surface of the board is making contact with the sanding belt.
2. Measure the thickness of the board at various points around the edge.
3. If there is a variation of thickness, the table can be adjusted accordingly.
4. DISCONNECT THE SANDER FROM THE POWER SOURCE!

—For minor adjustment, loosen the table mounting bolts shown in **Figure 31** and rotate the elevation screw flange.

—For major adjustment, mark the chain location on all sprockets, remove the chain from the sprocket to be adjusted, and turn the sprocket counterclockwise to raise the table. One quarter of a turn raises or lowers an elevation screw approximately 0.020"

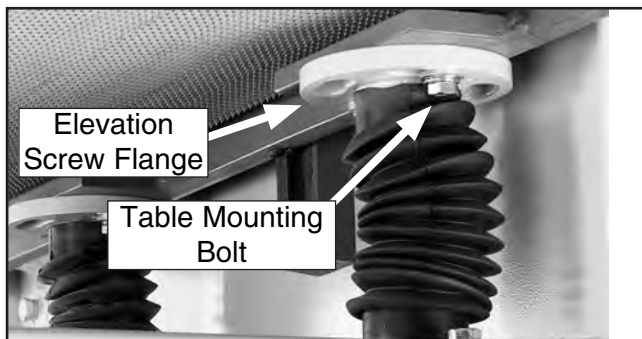

**Figure 31.** Table mounting bolts.

## **NOTICE**

**When adjusting the left front elevation screw, make the same adjustment to the left rear elevation screw. This ensures the height from the front to the back of the table remains unchanged. Do the same when adjusting the right elevation screws.**

5. Reinstall the chain, tighten the bolts, and test the machine.

# Pressure Rollers

### To adjust the pressure rollers:

1. DISCONNECT THE SANDER FROM THE POWER SOURCE!
2. Plane a 72" long 2x4 to a uniform thickness and cut it in half. Place one board along the length of the feed belt on the right-hand side and place the other board on the left-hand side.
3. With the sanding belt tensioned (**Figure 32**), move the sanding rollers by hand and manually raise the table until you hear the sandpaper just contact the surface of the wood. DO NOT continue to raise the table beyond that point.



**Figure 32.** Belt tension knob.

4. Connect the sander to the power source and make note of the reading on the digital display. Then manually lower the table 0.020" to 0.030". This is how much lower the infeed pressure roller should be set when compared to the sanding surface of the sanding roller.
5. DISCONNECT THE SANDER FROM THE POWER SOURCE!



- Loosen the roller lock nuts (**Figure 33**) on the infeed pressure roller. Turn the adjustment studs (**Figure 33**) to lower the pressure roller until it just touches the board.

**Note:** *DO NOT continue to lower the roller beyond that point.*

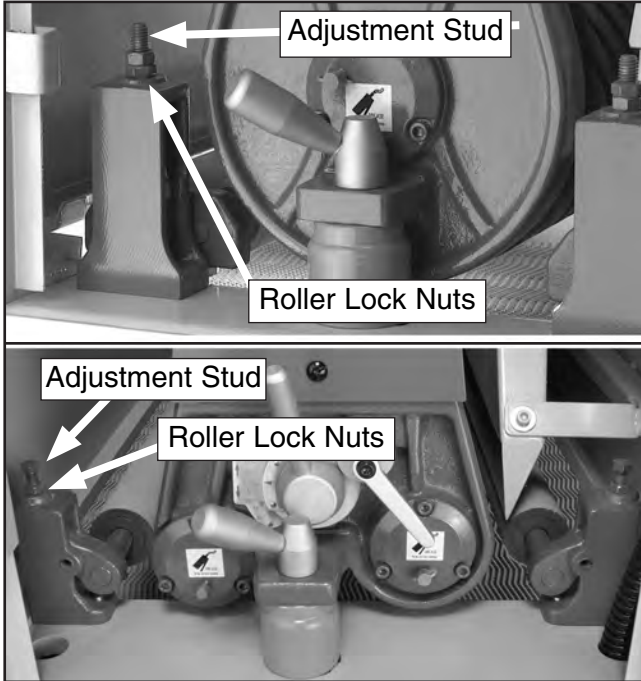

**Figure 33.** Pressure roller adjustment locations for platen and drum type sanders.

- Tighten the roller lock nuts.
- Connect power to the sander and observe the reading on the digital display. Then manually lower the table an additional 0.020" to 0.030".
- Loosen the roller lock nuts on the outfeed pressure roller. Turn the adjustment bolts and lower the pressure roller until it just touches the board. **Note:** *DO NOT continue to lower the roller beyond that point.*
- Tighten the roller lock nuts.

**Note:** *Variables such as feed rate, depth of the cut, and the type of sanding belt can play a big part in determining the proper amount of downward pressure exerted by the rollers. Experimentation is necessary to get the desired results. However, under no circumstances should the pressure rollers be set even, or higher than, the sanding roller.*

## V-Belt Adjustment

**To adjust either V-belt:**

- DISCONNECT THE SANDER FROM THE POWER SOURCE!
- Loosen the lock nut (**Figures 34 & 35**).

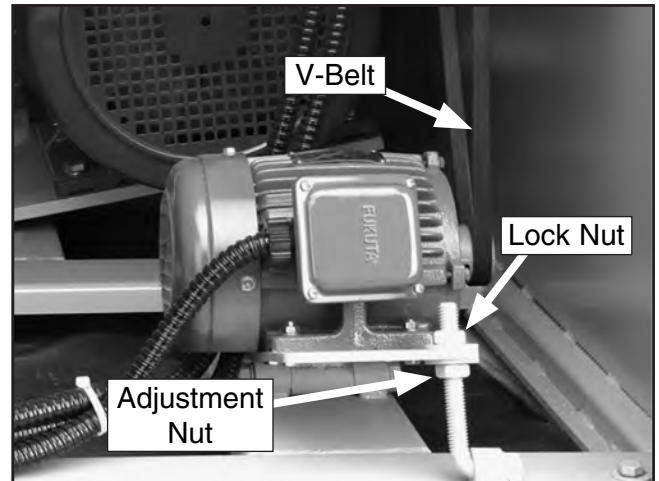

**Figure 34.** Table elevation V-belt.

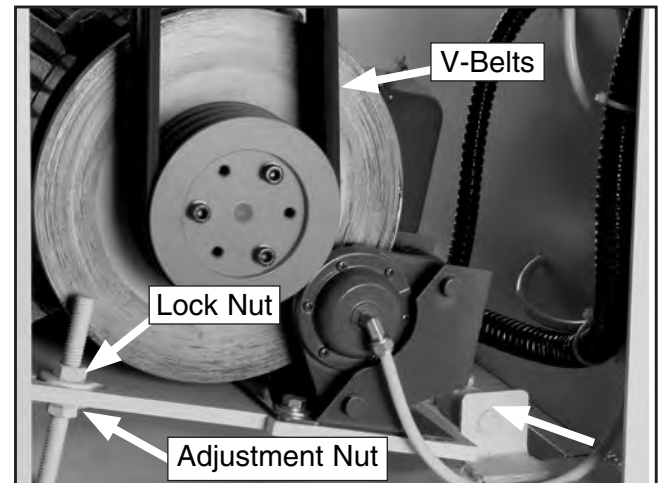

**Figure 35.** Sanding drum V-belts.

- Turn the adjustment nut up or down until the V-belts deflect 1" off of center when pushed with your finger.
- Retighten the lock nut.



# Air System Diagram

- |  |   |
|--|---|
| <b>A.</b> Shop Compressor                                      | <b>I.</b> Oscillation Timing Piston and Diaphragm Assy. |
| <b>B.</b> Air Pressure Regulator                               | <b>J.</b> Oscillation Speed Control Piston              |
| <b>C.</b> Emergency Brake Solenoid                             | <b>K.</b> Belt Tension Control Piston                   |
| <b>D.</b> Emergency Brake                                      | <b>L.</b> Belt Tension Control Switch                   |
| <b>E.</b> Air Distribution Manifold                            | <b>M.</b> Emergency Stop Button Switch                  |
| <b>F.</b> Airflow Adjustment Knob<br>(Oscillation Timing)      | <b>N.</b> Emergency Stop Push Brake Switch              |
| <b>G.</b> Speed Control Adjustment Knob<br>(Oscillation Speed) | <b>O.</b> Left Belt Limit Switch                        |
| <b>H.</b> Oscillation Controller Air Fork                      | <b>P.</b> Right Belt Limit Switch                       |
|  | <b>Q.</b> Belt Tension Limit Switch                     |
|  | <b>R.</b> Emergency Brake Contactor                     |

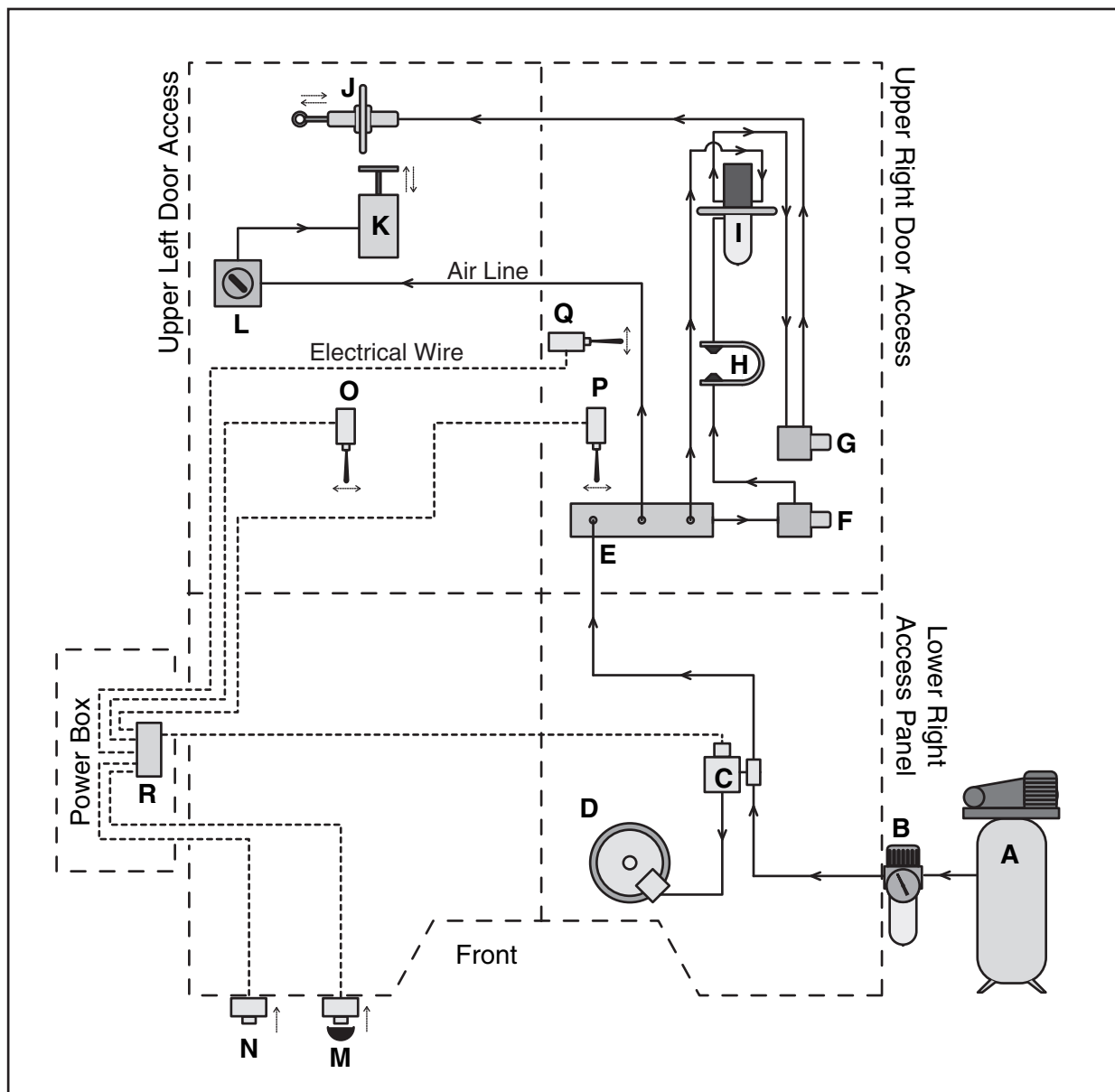

# Conveyor Belt Replacement

Make sure that you have a lifting device or another person to help in table removal.

Tools Needed:	Qty
Hex Wrench 9 mm.....	1
Combination Wrench 19 mm.....	1
Combination Wrench 12 mm.....	1
Combination Wrench 14 mm.....	1
Phillips Screwdriver #2.....	1
8' 2x4's .....	2
Permanent Marker .....	1

To remove the conveyor belt use **Figure 37** and follow the steps below:

1. Raise the table up so the conveyor belt is approximately two-inches away from the sanding roller or platen, and then **DISCONNECT THE SANDER FROM THE POWER SOURCE!**
2. Remove the gearbox mounting bracket, and with an assistant's help, slide the motor and gearbox from the roller shaft and lower it to the floor.  
  
**Note:** Do not loosen the two vibration dampener washers shown in **Figure 37**.
3. Remove two table height limit switches.
4. Remove both lower access panels.
5. Remove the left and right table guides.
6. Using a permanent marker, mark all four lead screw flange positions (**Figure 36**), and remove all hex bolts from the flanges.

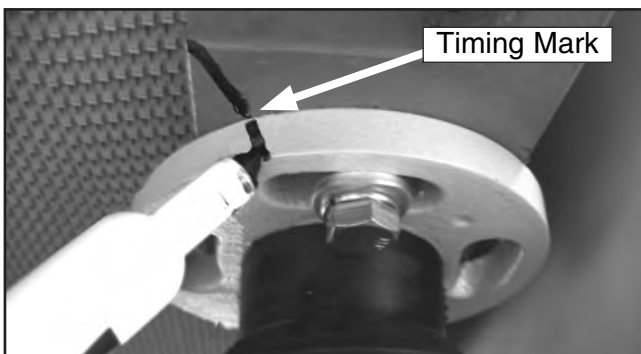

**Figure 36.** Marking lead screw for reassembly.

7. Insert the 2x4' wooden studs under the table for support, and with help, lift the table slightly and move it out of the rear of the machine.
8. Disconnect the limit switch, remove all mounting screws, and remove the emergency stop push-panel assembly.
9. Turn both tracking adjustment bolts counter-clockwise five turns, remove one roller support, and slide the drum out of the table assembly.
10. Remove the old conveyor belt. Inspect rollers, bearings, table for wear and replace as required.
11. Install the new conveyor belt. **Note:** *The belt is non-directional.*
12. Install the front roller, the roller support, and turn both tracking adjustment bolts clockwise equally so the conveyor belt becomes taut and does not hang loose. **DO NOT OVERTIGHTEN** the belt.
13. With a helper, install the table from the rear in a similar fashion as it was removed.
14. Install the table guides and both lower access panels.
15. Align the lead screw flanges with the marks made in **Step 6**, and install the hex bolts.
16. Install the table height limit switches so the upper switch clicks when the conveyor surface is 1/4" away from the sandpaper, and the lower switch clicks when the conveyor table is 1/4" higher than its lowest position. Make sure that you test your settings with the handwheel manually so you don't crash the table if incorrectly set the first time around.
17. With a helper, install the gearbox, vibration dampener washers, and mounting bracket.
18. Install the emergency stop push-panel assembly and the limit switch.
19. Start the conveyor motor and turn the conveyor tracking bolts as required until the conveyor belt tracks straight without loading up on one side of the table.



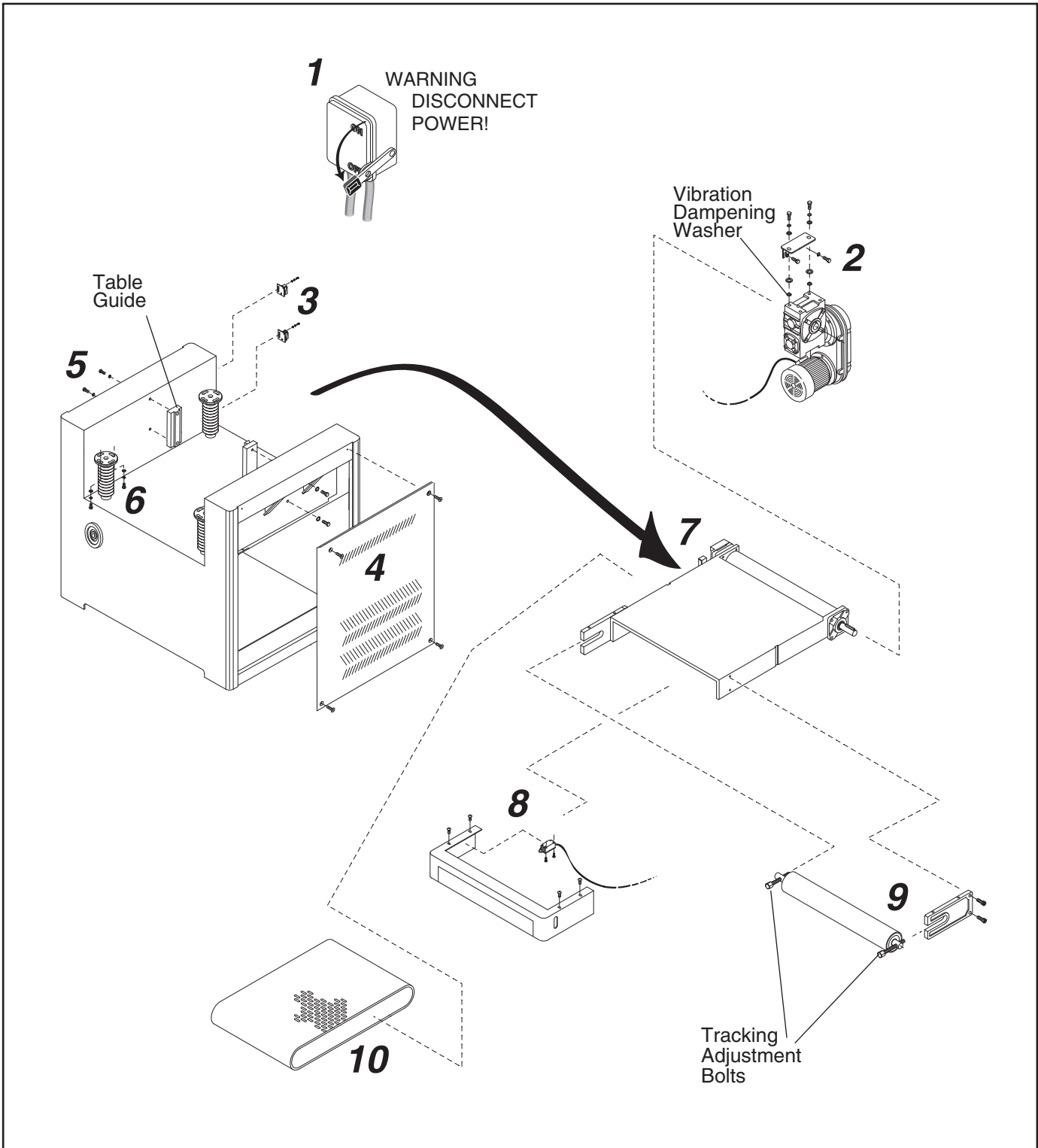

**Figure 37.** Conveyor belt removal sequence.



# Feed Belt Tension

Tools Needed:	Qty
Wrench or Socket 20mm.....	1
Phillips Screwdriver #2 .....	1

## To adjust the feed belt tension:

1. DISCONNECT THE SANDER FROM THE POWER SOURCE!
2. Find the adjustment ports in the safety guard (**Figure 38**) at the front end of the feed table.
3. Turn both left and right adjustment bolts (**Figure 38**) clockwise equally to increase tension.

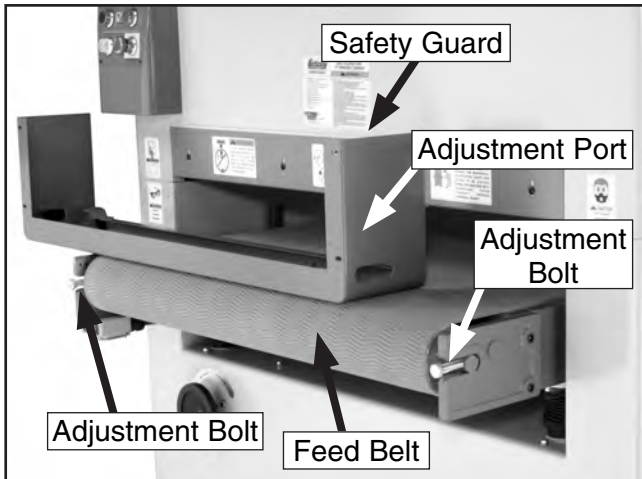

**Figure 38.** Feed belt tension adjustment bolts.  
**Note:** Safety guard removed for clarity.

4. When tensioned properly you should not be able to lift the feed belt off of the table surface or slide it back and forth.

## **!WARNING**

**DO NOT sand boards with the guard removed. Failure to follow this warning could result in serious personal injury.**

# Feed Belt Tracking

Tools Needed:	Qty
Hex Wrench 6mm .....	1

## **NOTICE**

**Adjust the feed belt tension before adjusting the feed belt tracking.**

## To adjust the feed belt tracking:

1. Turn the feed belt **ON**.
2. If the feed belt is tracking to the **right** side of the table, turn the **right** adjustment bolt (**Figure 38**) clockwise.
3. If the feed belt is tracking to the **left** side of the table, turn the **left** adjustment bolt clockwise.

**Note:** The edge of the feed belt should just touch the guide wheels as shown in **Figure 39**.

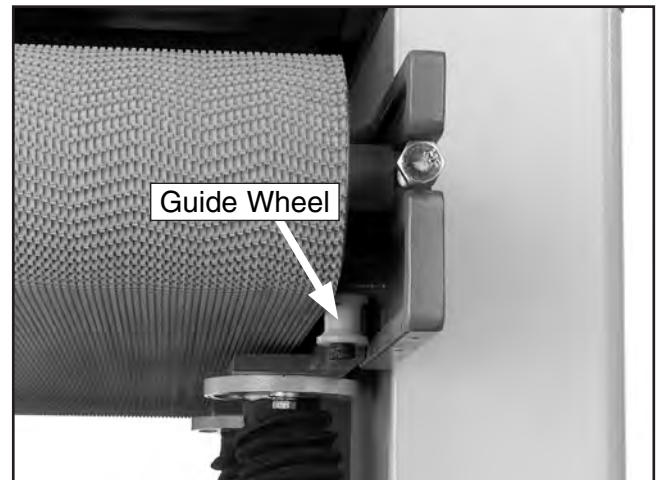

**Figure 39.** Guide wheels.

4. Run the feed belt for 3-5 minutes and recheck the tracking.
5. If the belt is still tracking correctly, replace the safety cover removed in the previous subsection.





# Troubleshooting

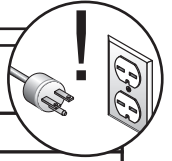

## Machine Operations

SYMPTOM	POSSIBLE CAUSE	CORRECTIVE ACTION
Motor will not start.	<ol style="list-style-type: none"> <li>1. Limit switch or emergency stop is at fault.</li> <li>2. Low voltage.</li> <li>3. Open circuit in motor or loose connections.</li> </ol>	<ol style="list-style-type: none"> <li>1. Correct situation that caused limit switch to engage, reset the emergency stop button.</li> <li>2. Check power line for proper voltage.</li> <li>3. Inspect all lead connections on motor for loose or open connections.</li> </ol>
Motor will not start; fuses or circuit breakers blow.	<ol style="list-style-type: none"> <li>1. Short circuit in line cord or plug.</li> <li>2. Short circuit in motor or loose connections.</li> <li>3. Incorrect fuses or circuit breakers in power line.</li> </ol>	<ol style="list-style-type: none"> <li>1. Inspect cord or plug for damaged insulation and shorted wires.</li> <li>2. Inspect all connections on motor for loose or shorted terminals or worn insulation.</li> <li>3. Install correct fuses or circuit breakers.</li> </ol>
Motor overheats.	<ol style="list-style-type: none"> <li>1. Motor overloaded.</li> <li>2. Air circulation through the motor restricted.</li> </ol>	<ol style="list-style-type: none"> <li>1. Reduce load on motor.</li> <li>2. Clean out motor to provide normal air circulation.</li> </ol>
Motor stalls (resulting in blown fuses or tripped circuit).	<ol style="list-style-type: none"> <li>1. Short circuit in motor or loose connections.</li> <li>2. Low voltage.</li> <li>3. Incorrect fuses or circuit breakers in power line.</li> <li>4. Motor overloaded.</li> </ol>	<ol style="list-style-type: none"> <li>1. Inspect connections on motor for loose or shorted terminals or worn insulation.</li> <li>2. Correct the low voltage conditions.</li> <li>3. Install correct fuses or circuit breakers.</li> <li>4. Reduce load on motor.</li> </ol>
Machine slows when operating.	<ol style="list-style-type: none"> <li>1. Feed rate too high.</li> <li>2. Depth of cut too great.</li> </ol>	<ol style="list-style-type: none"> <li>1. Feed workpiece slower.</li> <li>2. Reduce depth of cut.</li> </ol>
Loud, repetitious noise coming from machine.	<ol style="list-style-type: none"> <li>1. Pulley set screws or keys are missing or loose.</li> <li>2. Motor fan is hitting the cover.</li> <li>3. V-belt is defective.</li> </ol>	<ol style="list-style-type: none"> <li>1. Inspect keys and set screws. Replace or tighten if necessary.</li> <li>2. Tighten fan or shim cover.</li> <li>3. Replace V-belt. Refer to the <b>Maintenance</b> section.</li> </ol>

## Sanding Operations

Machine is loud, overheats or bogs down in the cut.	<ol style="list-style-type: none"> <li>1. Excessive depth of cut.</li> <li>2. Dull or dirty sanding belt.</li> </ol>	<ol style="list-style-type: none"> <li>1. Decrease depth of cut.</li> <li>2. Replace or clean sanding belt.</li> </ol>
Rounded workpiece edges.	<ol style="list-style-type: none"> <li>1. Excessive depth of cut.</li> </ol>	<ol style="list-style-type: none"> <li>1. Reduce depth of cut.</li> </ol>
Uneven thickness from left to right of board.	<ol style="list-style-type: none"> <li>1. Feed table not parallel to sanding roller.</li> <li>2. Conveyor belt is worn.</li> </ol>	<ol style="list-style-type: none"> <li>1. Adjust the table.</li> <li>2. Replace conveyor belt.</li> </ol>
Workpiece pads on feed belt.	<ol style="list-style-type: none"> <li>1. Pressure rollers set too high.</li> <li>2. Dirty conveyor belt.</li> <li>3. Conveyor belt is worn.</li> </ol>	<ol style="list-style-type: none"> <li>1. Lower pressure rollers.</li> <li>2. Clean conveyor belt.</li> <li>3. Replace conveyor belt.</li> </ol>
Straight strip of notches on workpiece.	<ol style="list-style-type: none"> <li>1. Pressure rollers are dirty or damaged.</li> </ol>	<ol style="list-style-type: none"> <li>1. Clean or repair pressure rollers.</li> </ol>

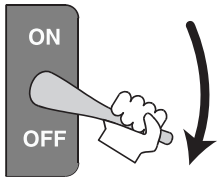

### ! WARNING

**For your safety, turn the power switch off and disconnect the sander from the power source and the air supply before starting the applicable troubleshooting.**



# Troubleshooting

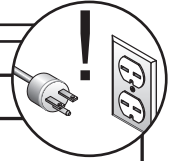

SYMPTOM	POSSIBLE CAUSE	CORRECTIVE ACTION
Snake shaped marks on workpiece.	1. Sanding belt damaged or dirty.	1. Clean or replace sanding belt.
Lines across width of workpiece.	1. Sanding belt seam is open or damaged.	1. Replace sanding belt.
Glossy spots or streaks on workpiece.	1. Worn sanding belt. 2. Rear pressure roller too low.	1. Replace sanding belt. 2. Raise rear pressure roller. <b>(See warning in Pressure Roller section!)</b>
Sanding belt clogs quickly.	1. Sanding belt grit too small for particular job. 2. Excessive depth of cut. 3. Wood is too moist. 4. Dust Collection is at fault.	1. Replace with a coarser grit sanding belt. 2. Reduce depth of cut. 3. Allow wood to dry out. 4. Service dust collection system or dust collector is undersized.
Sanding belt does not tension correctly; rollers pad under belt.	1. Low air pressure. 2. Air leaks in system.	1. Adjust air pressure to 75 PSI at primary regulator. 2. Inspect all hoses and connections for leaking air; use water on suspected area to detect bubbles.
Sanding belt runs off to one side, stopping the sander.	1. Air eye fork clogged. 2. Oscillation return valve closed. 3. Oscillation timing incorrect.	1. Clean the intake hole on the air eye fork. 2. Open valve. 3. Adjust oscillation timing.
Sanding belt will not start.	1. Sanding belt is not tensioned. 2. Limit switches engaged. 3. Emergency stop plate engaged.	1. Tension sanding belt. 2. Center sanding belt so it is not touching the limit switches. 3. Make sure emergency stop switch is released.
Poor, non-aggressive sanding results.	1. Worn sanding belt. 2. Sanding belt loaded with sawdust.	1. Replace sanding belt with a new one. 2. Clean sanding belt to unload sawdust.
Conveyor belt not tracking in center.	1. Conveyor rollers moved out of adjustment.	1. Re-adjust conveyor rollers.
Conveyor belt padding.	1. Conveyor rollers have incorrect tension. 2. Conveyor rollers contaminated with dirt or dust.	1. Adjust conveyor rollers to place more tension on the workpiece. 2. Clean conveyor rollers.
Emergency brake stops slow.	1. Air pressure incorrect. 2. Air leak in system. 3. Brake rotor contaminated with oil. 4. Brake pads worn out.	1. Adjust air pressure to 75 PSI. 2. Find and fix air leaks. 3. Clean brake rotor with automotive brake parts cleaner. 4. Replace brake pads.
Grinding noise when braking.	1. Brakes severely worn out.	1. Replace brake pads, have rotor turned (possibly replaced).

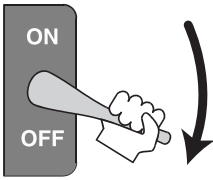

## ! WARNING

**For your safety, turn the power switch off and disconnect the sander from the power source and the air supply before starting the applicable troubleshooting.**





# Control Panel Component Locations

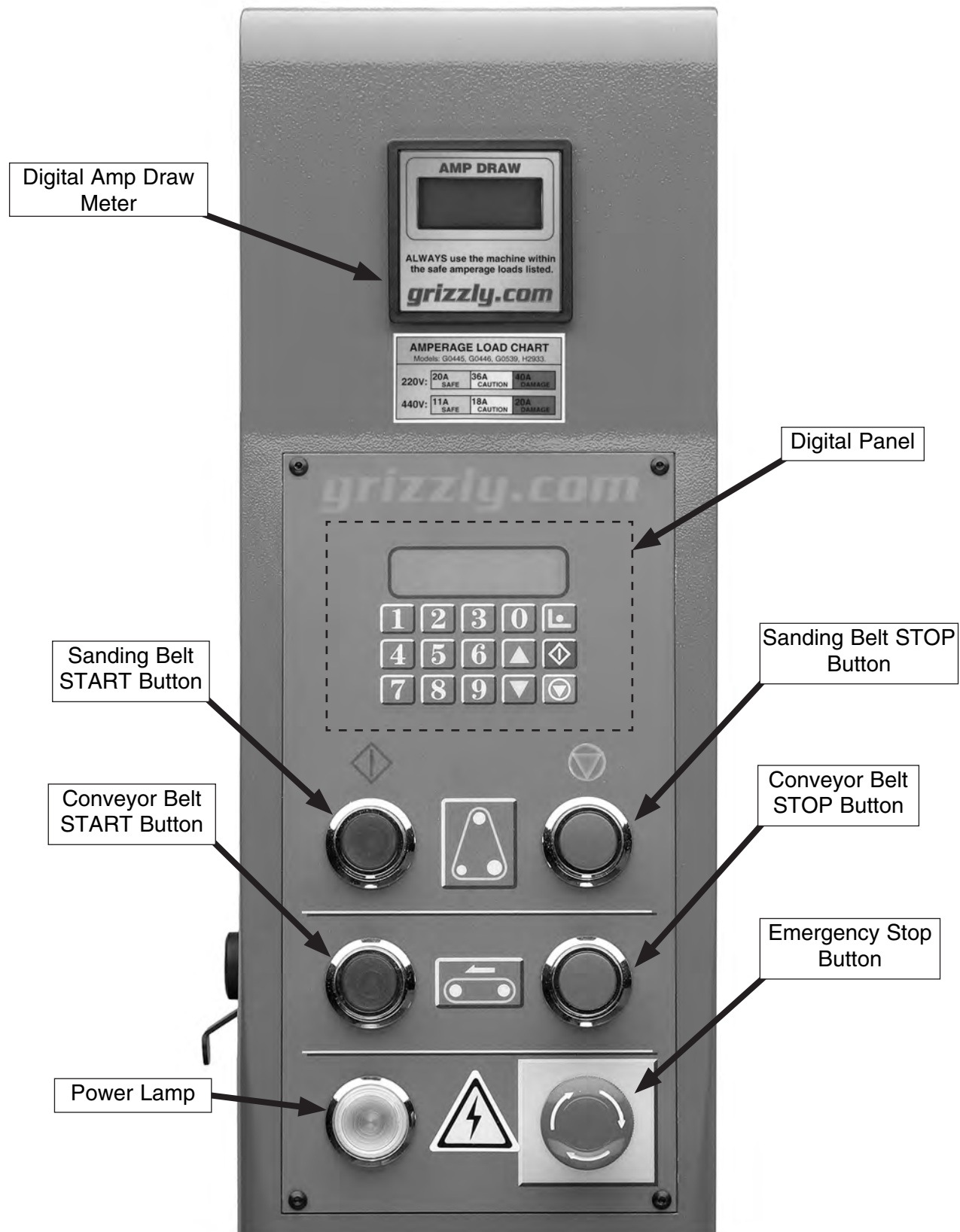

# Connection Wiring Diagram 220V/440V 3-Phase (G0445/G0582/G9962ZX)

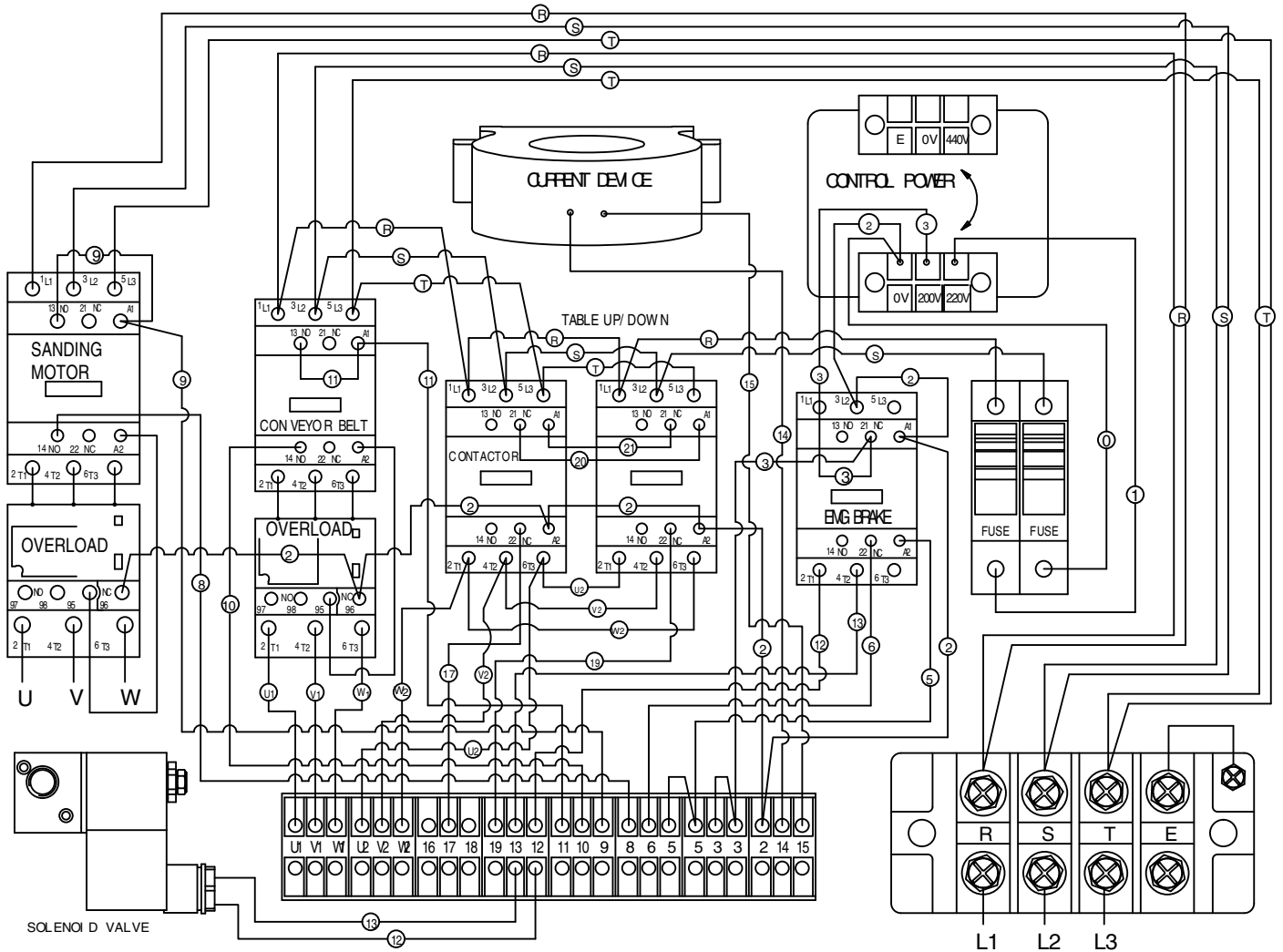

SANDING BELT MOTOR

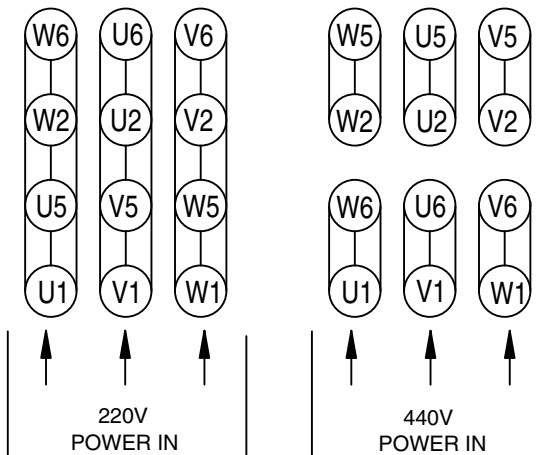

CONVEYOR BELT MOTOR,  
TABLE UP/DOWN MOTOR

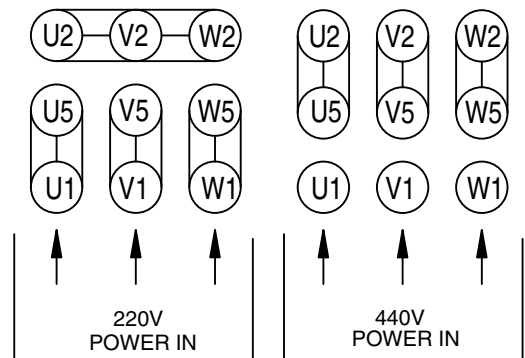

# Wiring Box Components (G0445/G0582/G9962ZX)

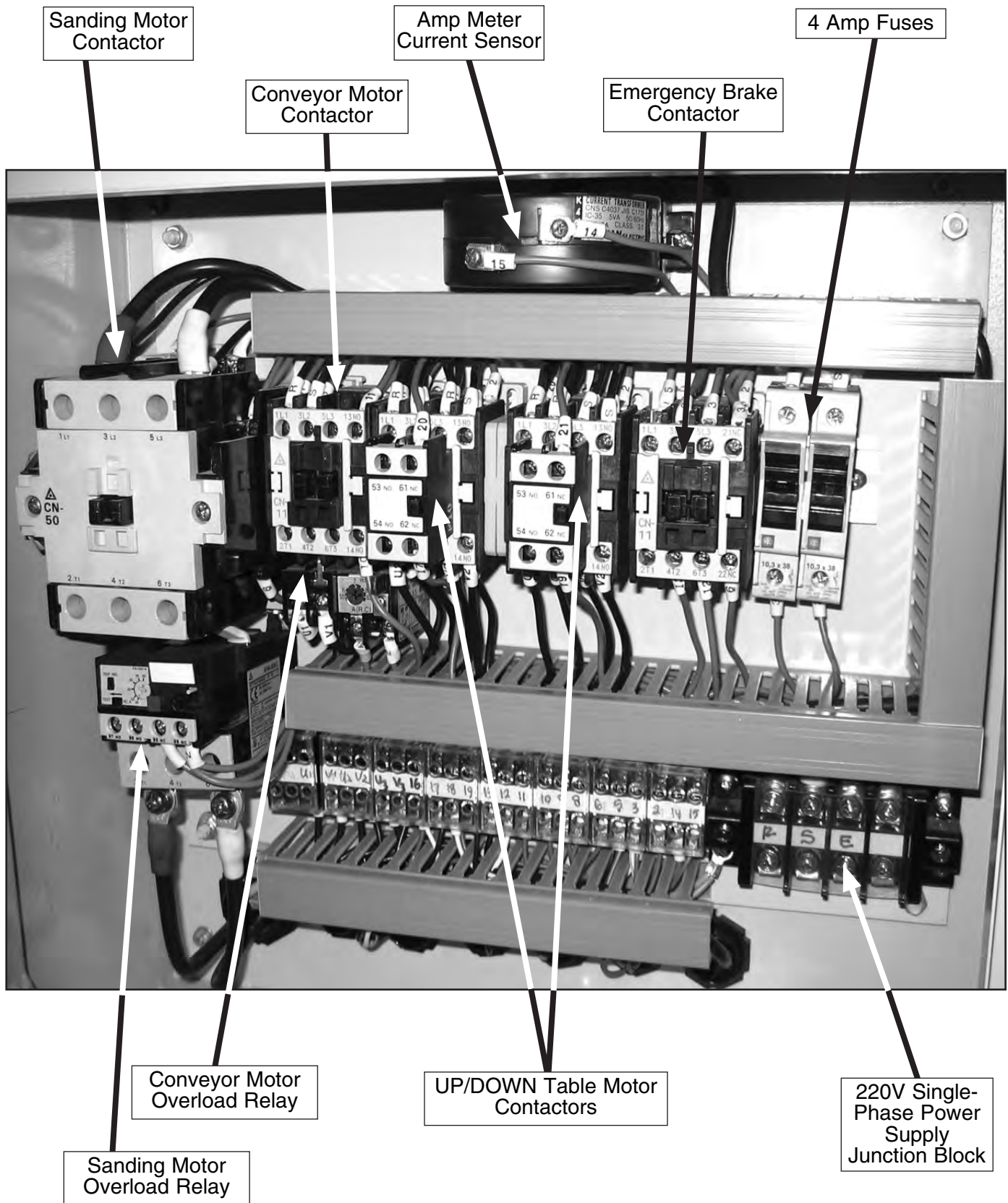

# Connection Wiring Diagram (G9962Z) 220V Single-Phase

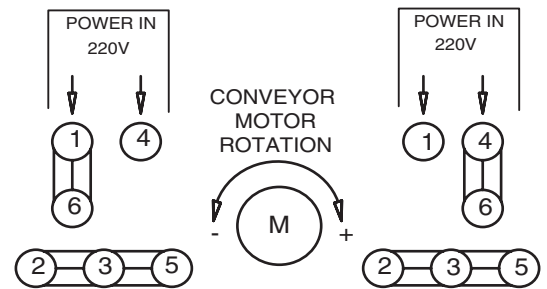
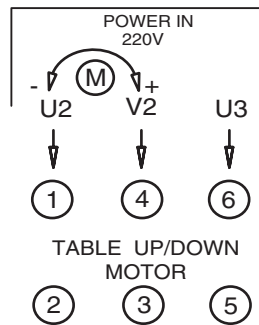
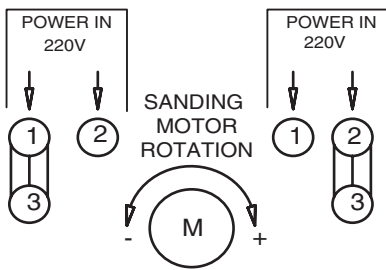
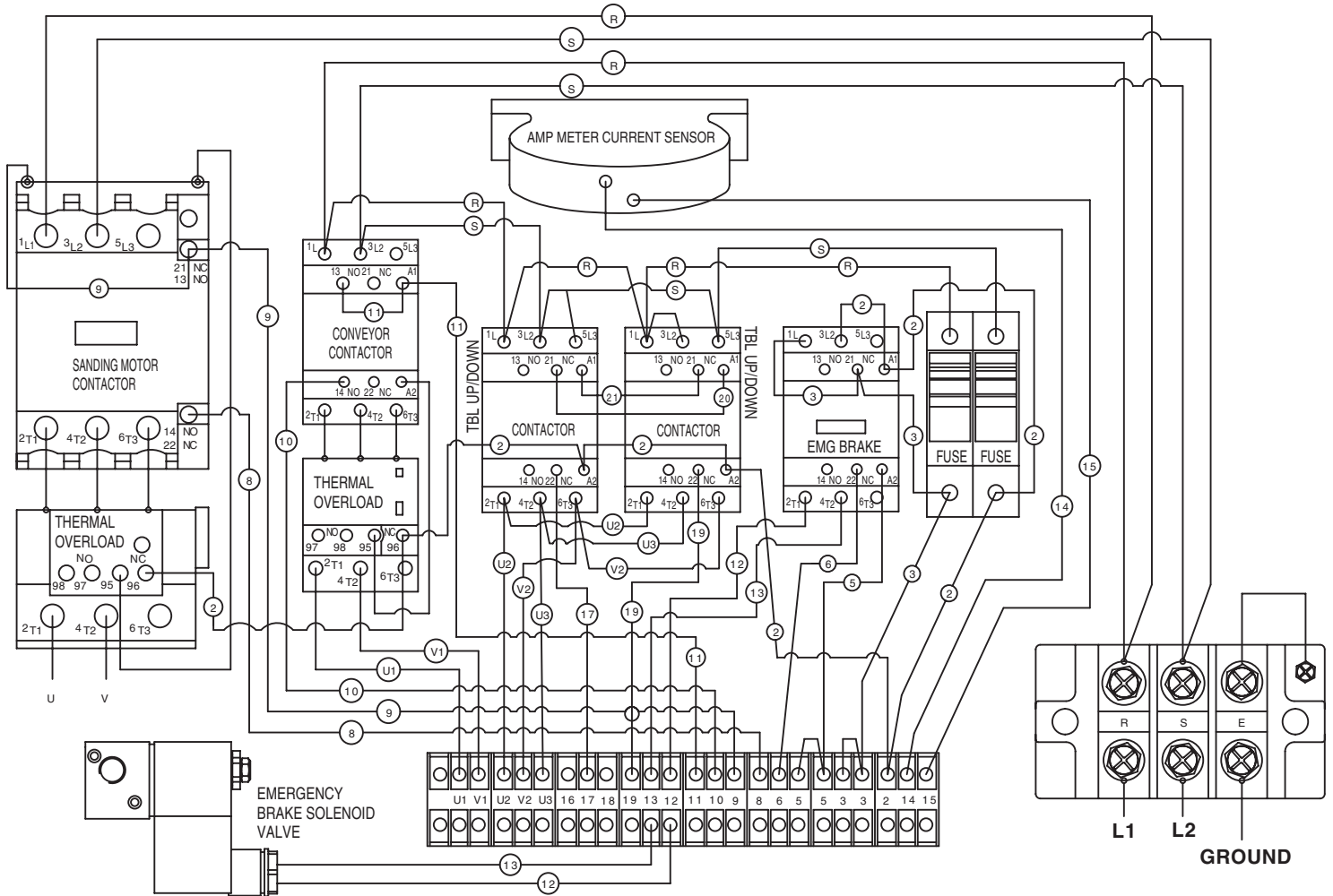

# Wiring Box Components (G9962Z)

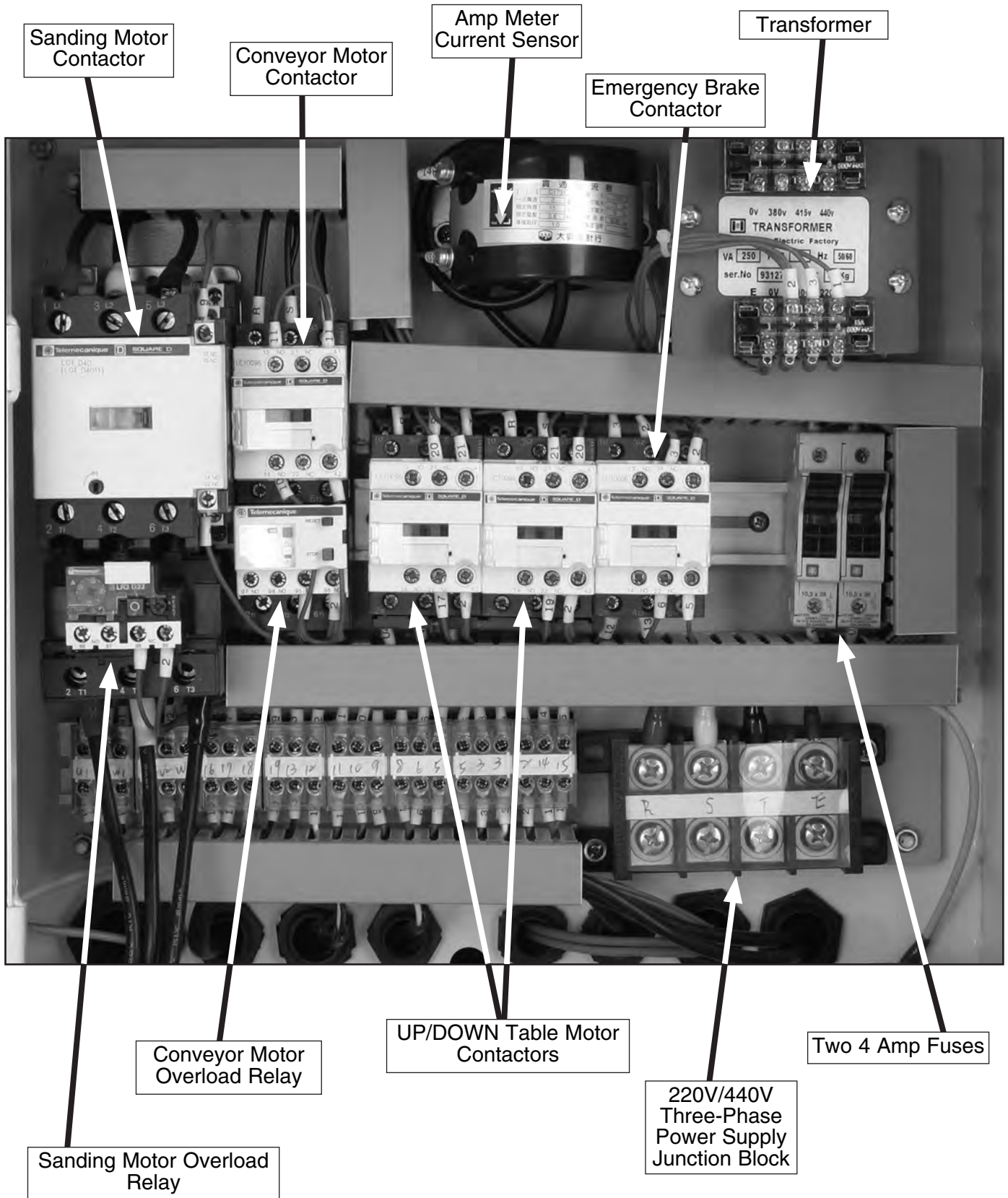

# General Electrical Diagram (G0445/G0582/G9962ZX) 220V/440V 3-Phase

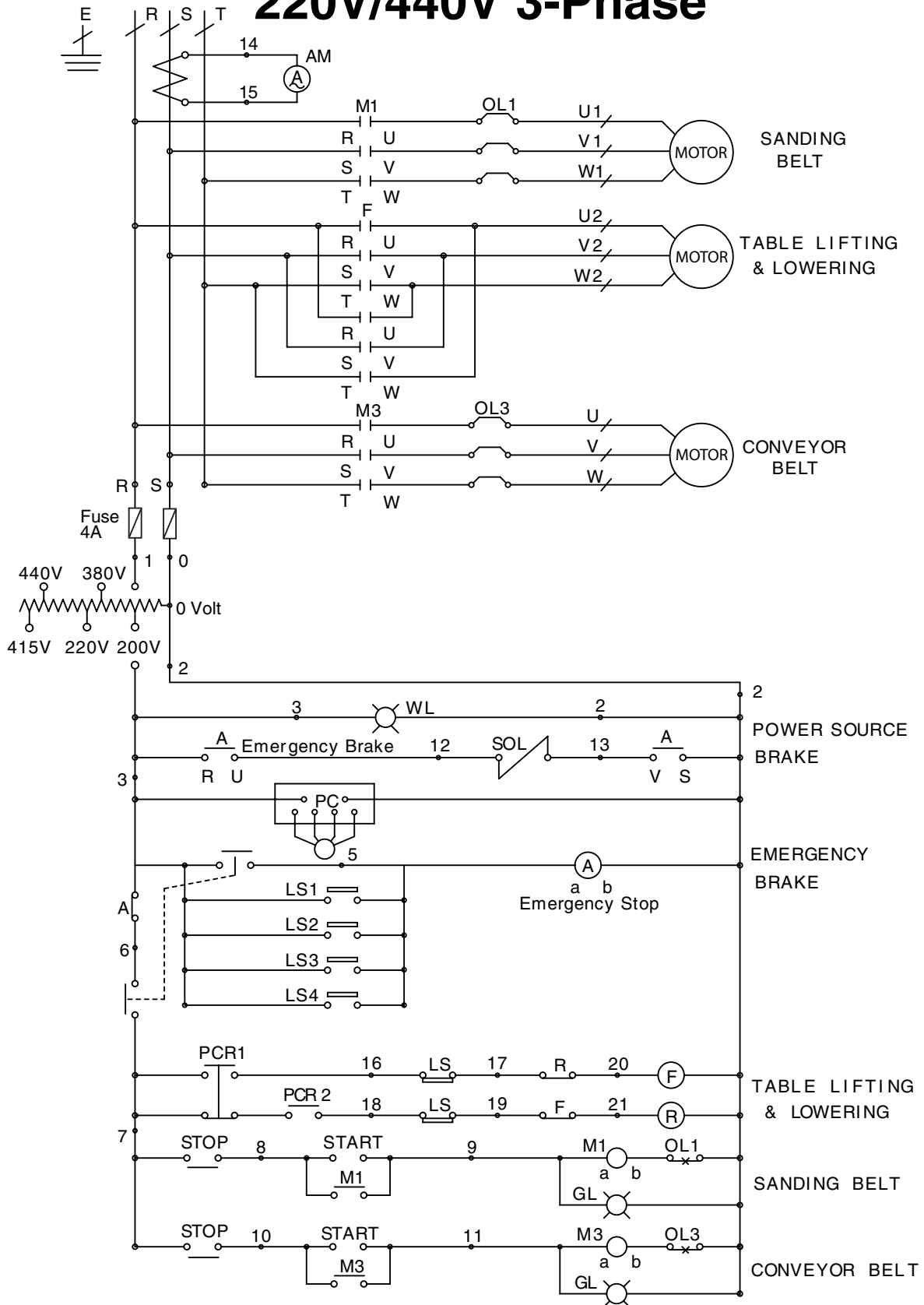

# General Electrical Diagram (G9962Z) 220V Single-Phase

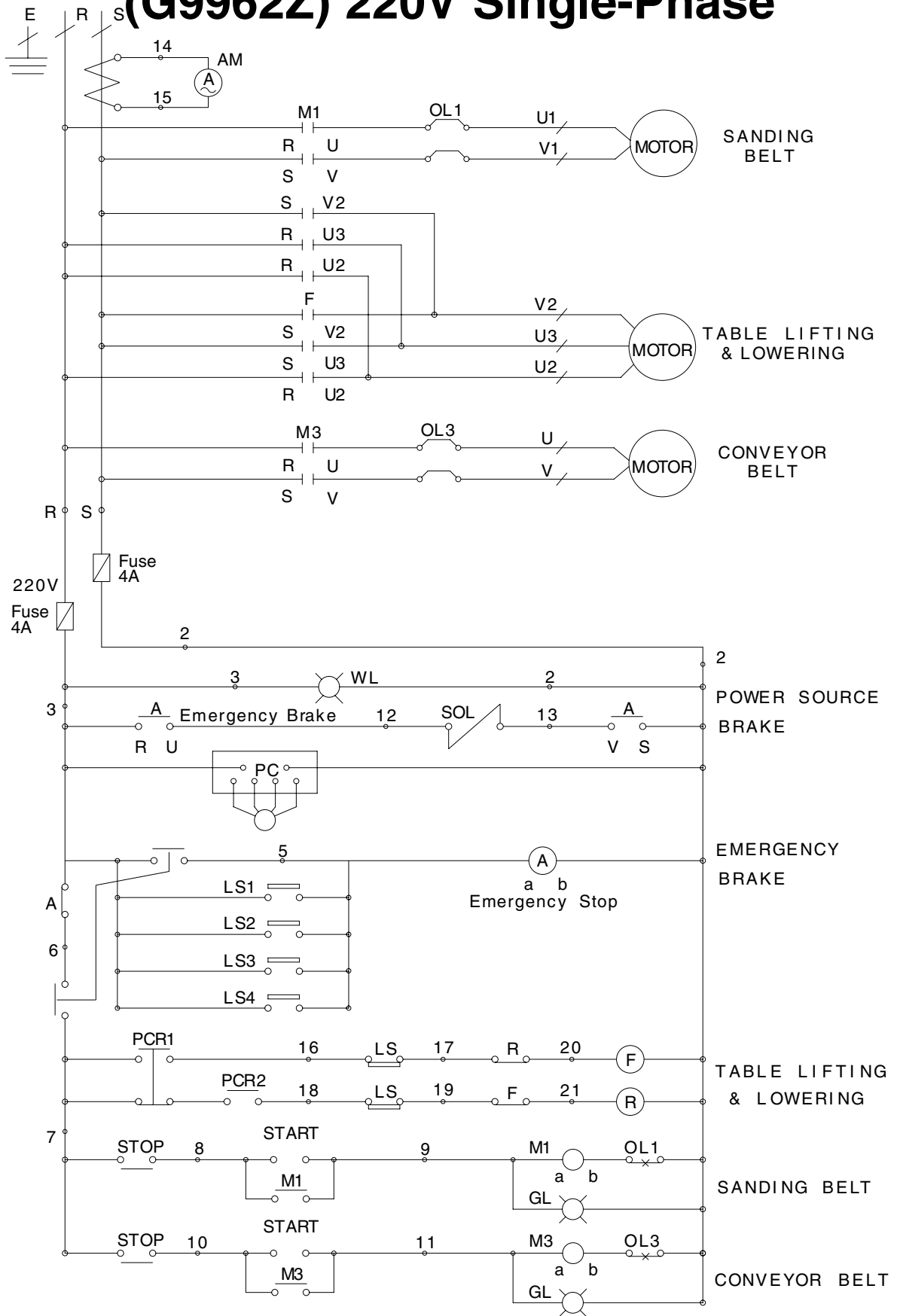

# Tool Box and Accessories Diagram

---

---

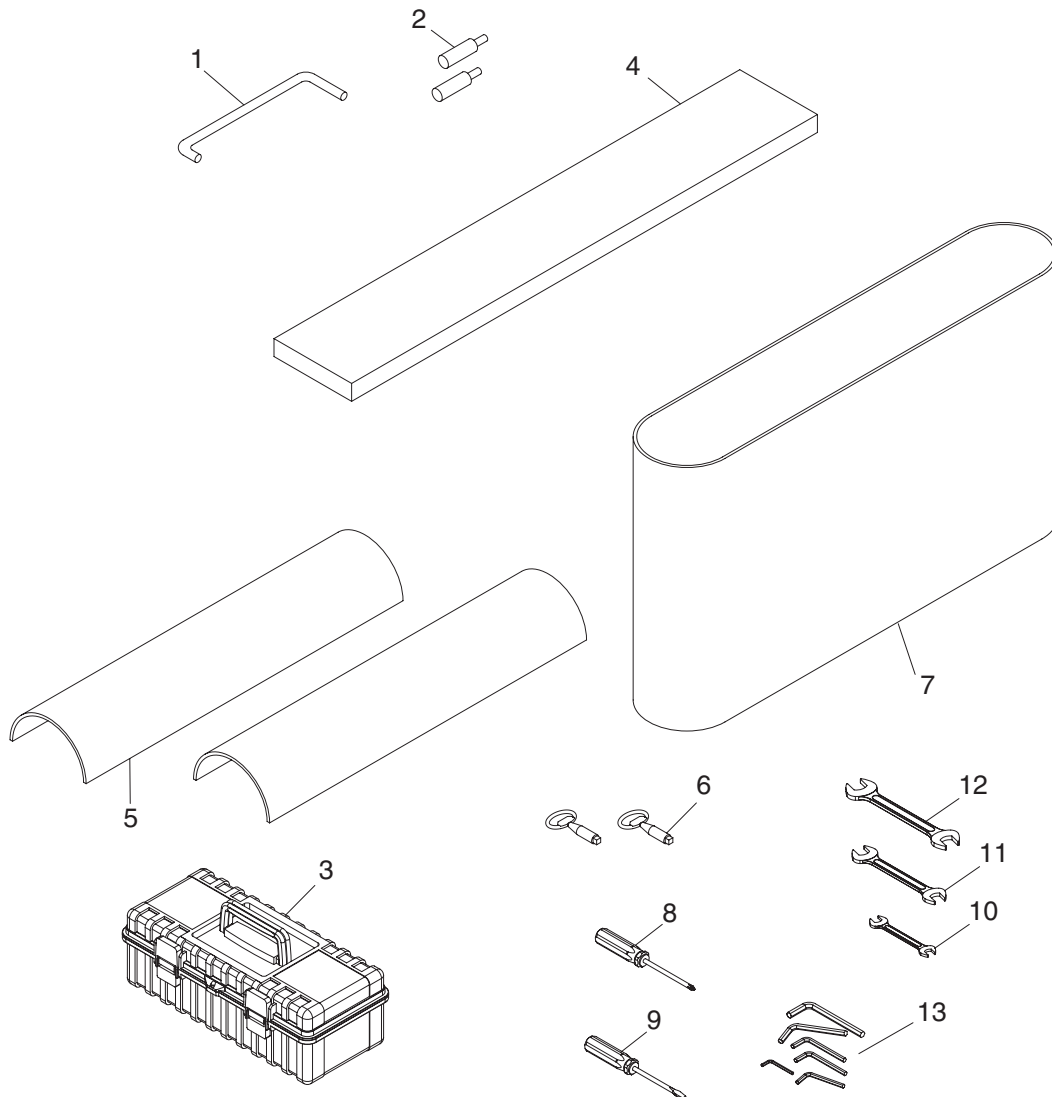

# Tool Box and Accessories Parts List

REF	PART #	DESCRIPTION
1	PH29330001	PLATEN REMOVAL TOOL (G0445/G0582)
2	P9962Z0002	LIMIT SWITCH ROD
3	P9962Z0003	TOOL BOX
4	P0582004	FELT PAD (G0445/G0582)
5	P0582005	GRAPHITE PAD (G0445/G0582)
6	P9962Z0006	DOOR HANDLE
7	G8677	SANDING BELT (#100) (G9962Z/G9962ZX)
7	G8679	SANDING BELT (#150) (G9962Z/G9962ZX)

REF	PART #	DESCRIPTION
7	P0582007	SANDING BELT (#100, 75" LONG) (G0445/G0582)
7	P0582009	SANDING BELT (#180, 75" LONG) (G0445/G0582)
8	P9962Z0008	PHILLIPS SCREWDRIVER
9	P9962Z0009	FLAT SCREWDRIVER
10	PWR810	8 X 10 WRENCH
11	PWR1214	12 x 14 WRENCH
12	PWR1719	17 x 19 WRENCH
13	P9962Z0013	HEX WRENCH SET





# Sanding Motor System Parts List

REF	PART #	DESCRIPTION
1101	P9962Z1101	MACHINE FRAME
1102	P9962Z1102	MOTOR BASE
1103	P9962Z1103	MOTOR BASE HINGE
1104	PN13	HEX NUT 1/2-13
1105	P9962Z1105	MOTOR BASE ADJUSTMENT ROD
1106	PLW07	LOCK WASHER 1/2
1107	PB78	HEX BOLT 1/2-13 x 1-1/4
1108	PW01	FLAT WASHER 1/2
1109	P9962Z1109	10 HP MOTOR (G9962Z)
1109	P9962ZX1109	10 HP MOTOR (G9962ZX/G0582/G0445)
1109-1	P9962Z1109-1	MOTOR FAN (G9962Z)
1109-2	P9962Z1109-2	MOTOR FAN COVER (G9962Z)
1109-1	P9962ZX1109-1	MOTOR FAN (G9962ZX/G0582/G0445)
1109-2	P9962ZX1109-2	FAN COVER (G9962ZX/G0582/G0445)
1110	P9962Z1110	PULLEY (G9962Z/G9962ZX)
1110	P05821110	PULLEY (G0582/G0445)
1111	PSB11	CAP SCREW 5/16-18 x 1-1/4
1112	PLW01	LOCK WASHER 5/16
1113	P9962Z1113	KEY 10 X 8 X 75
1114	PB03	HEX BOLT 5/16-18 X 1
1115	PLW01	LOCK WASHER 5/16
1116	P9962Z1116	DISC BRAKE
1118	P9962Z1118	PULLEY BUSHING
1119	PVB77	V-BELT B-77 (G9962Z/G9962ZX)
1119	PVA71	V-BELT A-71 (G0582/G0445)

REF	PART #	DESCRIPTION
1121	P9962Z1121	BRAKE BRACKET
1122	PW02	FLAT WASHER 3/8
1123	PB21	HEX BOLT 3/8-16 x 3/4
1124	P9962Z1124	TABLE LIFTING COLLAR
1125	PSB05	CAP SCREW 1/4-20 X 3/4
1126	P9962Z1126	LIMIT SWITCH
1127	P9962Z1127	LIMIT SWITCH PLATE
1128	PB19	HEX BOLT 1/4-20 X 1/2
1129	PW06	FLAT WASHER 1/4
1130	PSS18	SET SCREW 5/16-18 X 3/4
1131	P9962Z1131	COVER OF MOTOR BASE
1132	PW02	FLAT WASHER 3/8
1301	P9962Z1301	BRAKE BRACKET
1301-1	P9962Z1301-1	BRAKE BRACKET FRONT
1302-1	P9962Z1302-1	BRAKE LINING
1302-2	P9962Z1302-2	BRAKE LINING
1303	P9962Z1303	BRAKE ARBOR
1304	P9962Z1304	BRAKE SPRING
1305	P9962Z1305	BRAKE INSIDE PIECE
1306	PFH12M	FLAT HD SCR M6-1 X 25
1307	P9962Z1307	BRAKE PIN
1308	PSB10M	CAP SCREW M5-.8 X 15
1309	PR03M	EXT RETAINING RING 12MM
1310	PLW04	LOCK WASHER 3/8
1311	PN08	HEX NUT 3/8-16
1312	PSB26M	CAP SCREW M6-1.0 X 12
1313	P9962Z1313	BRAKE GASKET



# Table Lift System Diagram

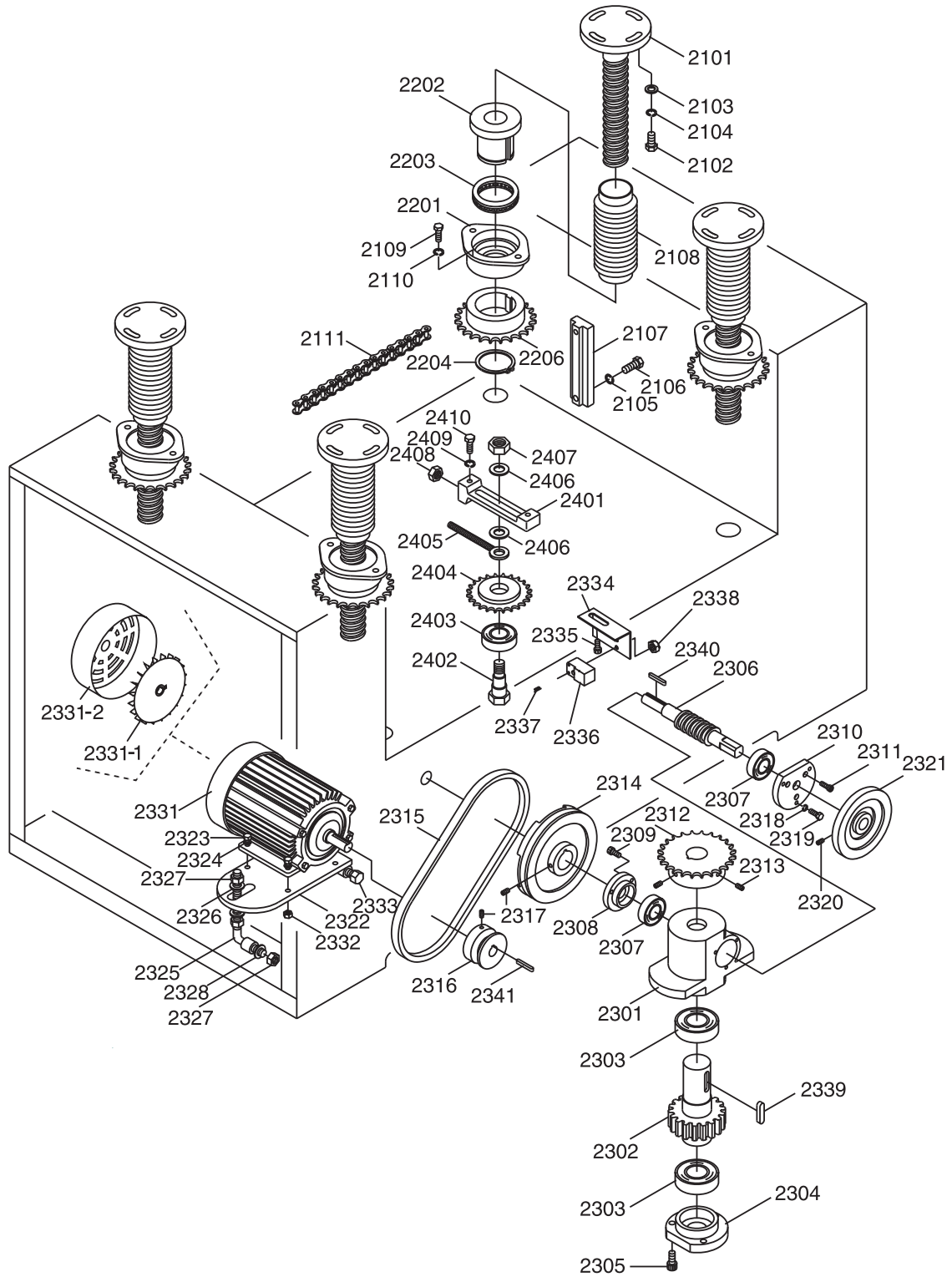

# Table Lift System Parts List

REF	PART #	DESCRIPTION
2101	P9962Z2101	ELEVATION SCREW
2102	PB03	HEX BOLT 5/16-18 X 1
2103	PW07	FLAT WASHER 5/16
2104	PLW01	LOCK WASHER 5/16
2105	PLW04	LOCK WASHER 3/8
2106	PB18	HEX BOLT 3/8-16 X 1
2107	P9962Z2107	ELEVATION SLIDE
2108	P9962Z2108	DUST GUARD BELLOW
2109	PB07	HEX BOLT 5/16-18 X 3/4
2110	PLW01	LOCK WASHER 5/16
2111	P9962Z2111	CHAIN
2201	P9962Z2201	COLLAR HOUSING
2202	P9962Z2202	COLLAR
2203	P9962Z2203	THRUST BEARING 51107
2204	P9962Z2204	CLIP
2206	P9962Z2206	SPROCKET WHEEL
2301	P9962Z2301	ELEVATION GEAR BOX
2302	P9962Z2302	WORM GEAR
2303	P6005	BEARING 6005Z
2304	P9962Z2304	BEARING CAP
2305	PSB05	CAP SCREW 1/4-20 X 3/4
2306	P9962Z2306	WORM SHAFT
2307	P6002	BEARING 6002Z
2308	P9962Z2308	BEARING CAP
2309	PSB33	CAP SCREW 10-24 X 3/4
2310	P9962Z2310	BEARING CAP
2311	PSB01	CAP SCREW 1/4-20 X 5/8
2312	P9962Z2312	SPROCKET WHEEL
2313	PSS08	SETSCREW 5/16-18 X 1/2
2314	P9962Z2314	PULLEY
2315	P9962Z2315	V-BELT A36: (1-PH)
2315A	P9962Z2315A	V-BELT A37: (3-PH)
2316	P9962Z2316	PULLEY
2317	PSS07	SETSCREW 1/4-20 X 1/2
2318	PLW01	LOCK WASHER 5/16
2319	PB07	HEX BOLT 5/16-18 X 3/4
2320	PSS07	SETSCREW 1/4-20 X 1/2

REF	PART #	DESCRIPTION
2321	P9962Z2321	HANDWHEEL
2322	P9962Z2322	MOTOR BASE
2323	PB31	HEX BOLT 1/4-20 X 1
2324	PLW02	LOCK WASHER 1/4
2325	P9962Z2325	MOTOR BASE ROD
2326	PW01	FLAT WASHER 1/2
2327	PN06	HEX NUT 1/2-12
2328	PLW07	LOCK WASHER 1/2
2331	P9962Z2331	1/3 HP MOTOR (G9962Z)
2331-1	P9962Z2331-1	MOTOR FAN (G9962Z)
2331-2	P9962Z2331-2	MOTOR FAN COVER (G9962Z)
2331	P9962ZX2331	1/4 HP MOTOR (G9962ZX/G0582/G0445)
2331-1	P9962ZX2331-1	MOTOR FAN (G9962ZX/G0582/G0445)
2331-2	P9962ZX2331-2	MOTOR COVER (G9962ZX/G0582/G0445)
2332	PN05	HEX NUT 1/4-20
2333	PB89	HEX BOLT 1/2-12 X 4-1/2
2334	P9962Z2334	PROXIMITY SWITCH PLATE
2335	PB19	HEX BOLT 1/4-20 X 1/2
2336	P9962Z2336	PROXIMITY SWITCH
2337	PS55M	PHLP HD SCR M3-0.5 X 35
2338	PN07M	HEX NUT M3-0.5
2339	P9962Z2339	KEY 5/16 X 5/16 X 3/4
2340	P9962Z2340	KEY 4 X 4 X 20
2341	P9962Z2341	KEY 4 X 4 X 10
2401	P9962Z2401	SPROCKET WHEEL ADJUST PIECE
2402	P9962Z2402	SPROCKET WHEEL SHAFT
2403	P6003	BEARING 6003ZZ
2404	P9962Z2404	ADJUST SPROCKET WHEEL
2405	P9962Z2405	SPROCKET WHEEL ADJUST ROD
2406	PW02	FLAT WASHER 3/8
2407	PN08	HEX NUT 3/8-16
2408	PN02	HEX NUT 5/16-18
2409	PLW01	LOCK WASHER 5/16
2410	PB07	HEX BOLT 5/16-18 X 3/4



# Conveyor System Diagram

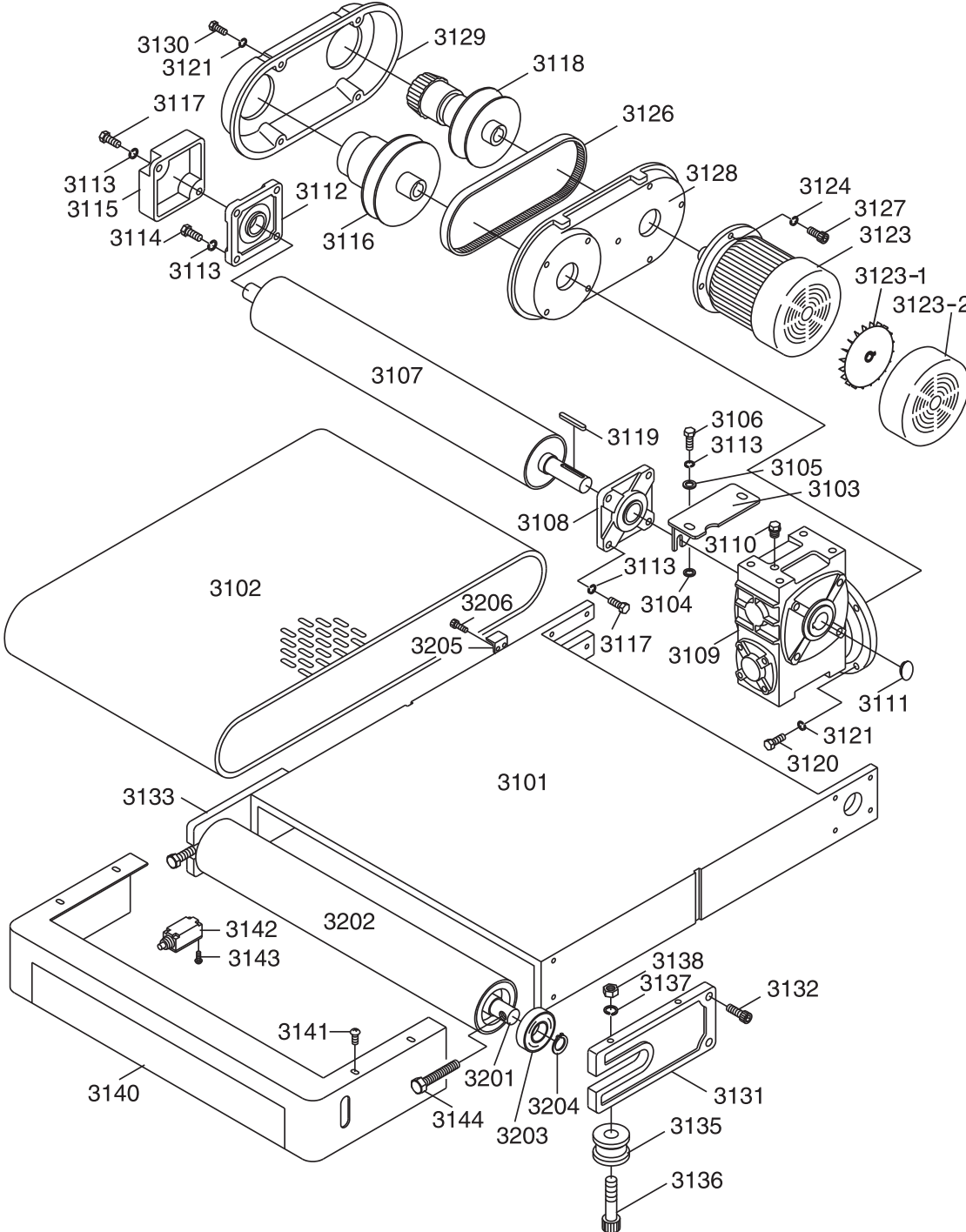

# Conveyor System Parts List

REF	PART #	DESCRIPTION
3101	P9962Z3101	CONVEYOR TABLE
3102	P9962Z3102	CONVEYOR BELT
3103	P9962Z3103	GEARBOX FIX PLATE
3104	P9962Z3104	CUSHION
3105	PW02	FLAT WASHER 3/8
3106	PB18	HEX BOLT 3/8-16 X 1
3107	P9962Z3107	OUTFEED ROLLER
3108	P9962Z3108	BEARING UCF205
3109	P9962Z3109	REDUCER
3110	P9962Z3110	PLUG
3111	P9962Z3111	PLUG
3112	P9962Z3112	BEARING UCF205
3113	PLW04	LOCK WASHER 3/8
3114	PB24	HEX BOLT 3/8-16 X 1-1/4
3115	P9962Z3115	BEARING CAP
3116	P9962Z3116	DRIVE PULLEY
3117	PB16	HEX BOLT 3/8-16 X 1-1/2
3118	P9962Z3118	DRIVE PULLEY
3119	PK66M	KEY 7 X 7 X 55
3120	PB07M	HEX BOLT M8-1.25 X 25
3121	PLW04M	LOCK WASHER 8MM
3123	P9962Z3123	1 HP MOTOR 1-PH (G9962Z)
3123-1	P9962Z3123-1	MOTOR FAN COVER (G9962Z)
3123-2	P9962Z3123-2	MOTOR FAN (G9962Z)
3123	P9962ZX3123	1 HP MOTOR 3-PH (G9962ZX/G0582/G0445)
3123-1	P9962ZX3123-1	MOTOR FAN (G9962ZX/G0582/G0445)

REF	PART #	DESCRIPTION
3123-2	P9962ZX3123-2	FAN COVER (G9962ZX/G0582/G0445)
3124	PLW06M	LOCK WASHER 10MM
3126	P9962Z3126	TIMING BELT
3127	PB32M	HEX BOLT M10-1.5 X 25
3128	P9962Z3128	VARIABLE SPEED BASE PLATE
3129	P9962Z3129	VARIABLE SPEED COVER
3130	PB09M	HEX BOLT M8-1.25 X 20
3131	P9962Z3131	INFEED ROLLER BRACKET
3132	PSB16	CAP SCREW 3/8-16 X 3/4
3133	P9962Z3133	INFEED ROLLER BRACKET
3135	P9962Z3135	POSITIONING WHEEL
3136	PSB70	CAP SCREW 5/16-18 X 2
3137	PLW01	LOCK WASHER 5/16
3138	PN02	HEX NUT 5/16-18
3140	P9962Z3140	FRONT BRAKE COVER
3141	PS04	PHLP HD SCR 1/4-20 X 1/2
3142	P9962Z3142	LIMIT SWITCH
3143	PS31	PHLP HD SCR #10-24 X 1-3/4
3144	PB74	HEX BOLT 1/2-13 X 3
3201	P9962Z3201	INFEED ROLLER SHAFT
3202	P9962Z3202	INFEED ROLLER
3203	P6206	BEARING 6206ZZ
3204	PR15M	EXT RETAINING RING 30MM
3205	P9962Z3205	ELEVATION LIMITER
3206	PSB32	CAP SCREW 1/4-20 X 1-1/4



# Feed, Drum, and Pressure Roller Diagram

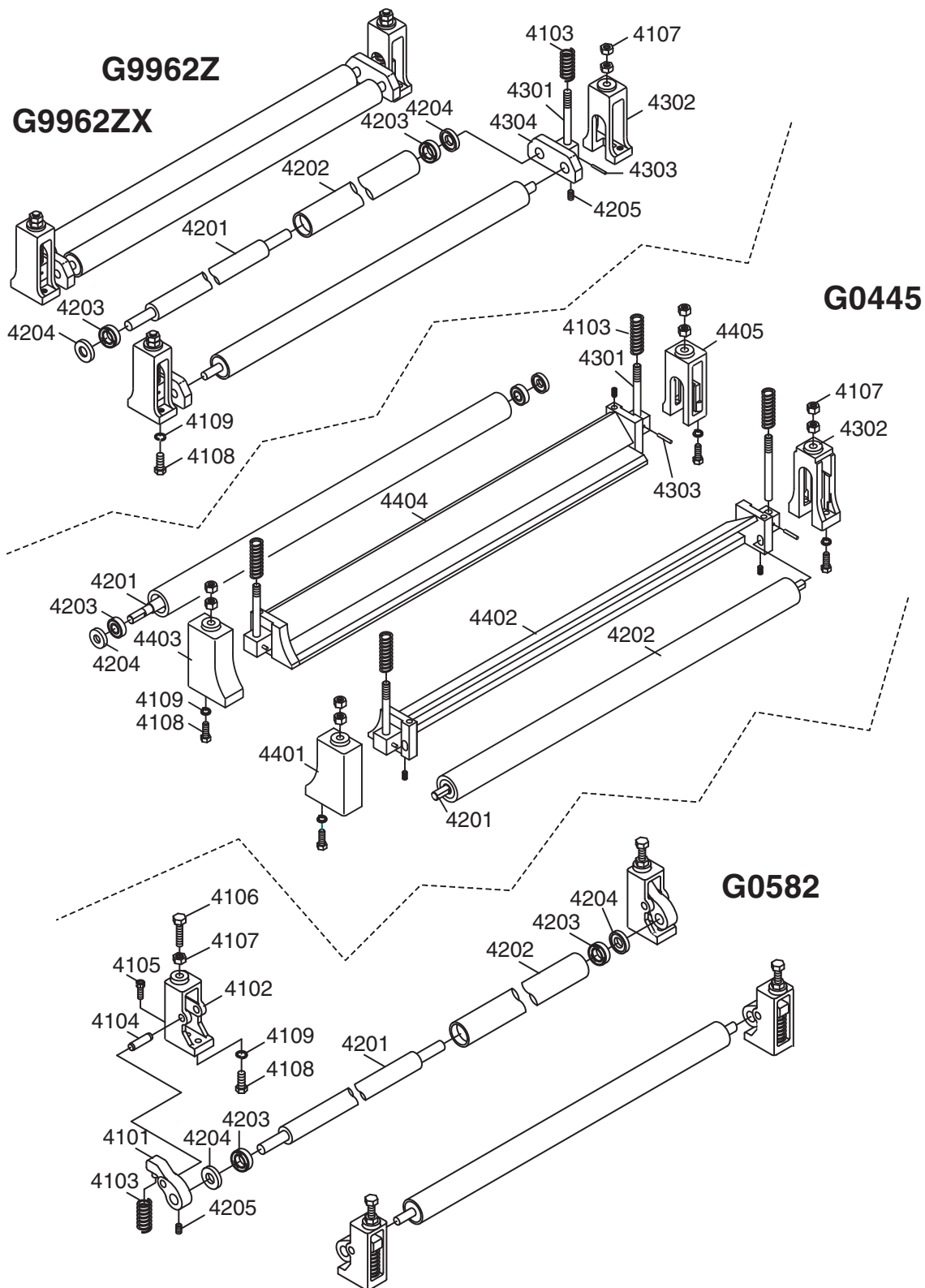

# Feed, Drum, and Pressure Roller Parts List

REF	PART #	DESCRIPTION
4101	P05824101	PISTON SLIDE RAIL (G0582)
4102	P05824102	PISTON BRACKET (G0582)
4103	P9962Z4103	COMPRESSION SPRING
4104	P9962Z4104	ROD 10 X 35 (G0582)
4105	PSS07	SET SCREW 1/4-20 X 1/2 (G0582)
4106	PB11	HEX BOLT 5/16-18 X 1-1/2 (G0582)
4107	PN02	HEX NUT 5/16-18
4108	PB12	HEX BOLT 5/16-18 X 1-1/4
4109	PLW01	LOCK WASHER 5/16
4201	P9962Z4201	PISTON ROLLER SHAFT
4202	P9962Z4202	PISTON ROLLER
4203	P6001	BEARING 6001ZZ
4204	P9962Z4204	SHAFT BEARING COLLAR

REF	PART #	DESCRIPTION
4205	PSS07	SETSCREW 1/4-20 X 1/2
4301	P9962Z4301	PISTON ROD (G9962Z/G9962ZX/G0445)
4302	P9962Z4302	BRACKET (G9962Z/G9962ZX/G0445)
4303	PRP55M	ROLL PIN 3 x 27
4304	P9962Z4304	SLIDERAIL (G9962Z/G9962ZX)
4401	P04454301	BRACKET (G0445)
4402	P04454302	DEFLECTOR (G0445)
4403	P04454303	BRACKET (G0445)
4404	P04454304	DEFLECTOR (G0445)
4405	P04454305	BRACKET (G0445)



# Sanding Drum and Platen System Diagram

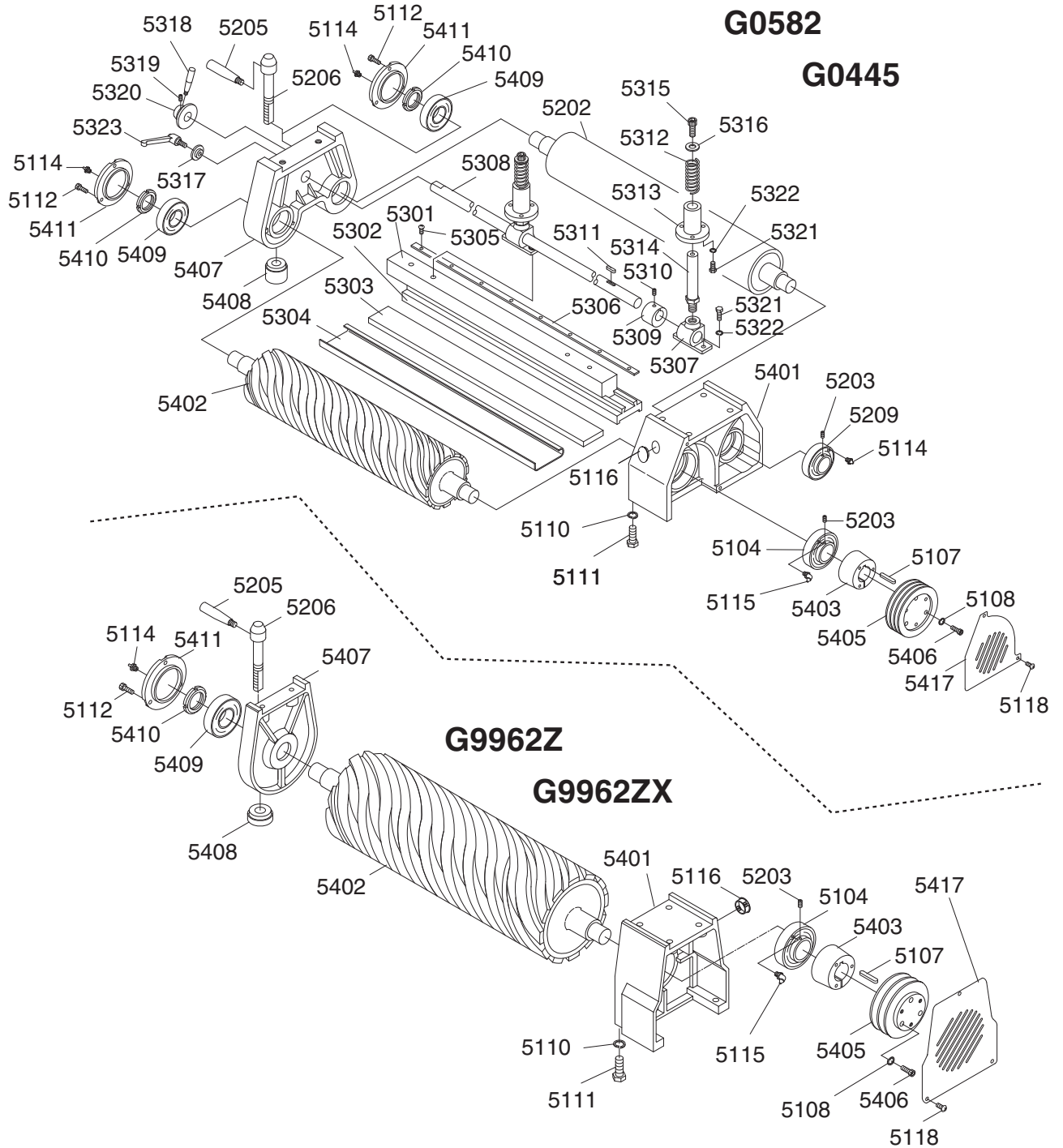

# Sanding Drum, and Platen System Parts List

REF	PART #	DESCRIPTION
5104	P9962Z5104	BEARING UCC206
5107	PK11	KEY 5/16 X 5/16 X 1-3/16
5108	PLW01	LOCK WASHER 5/16
5110	PLW07	LOCK WASHER 1/2
5111	PB41	HEX BOLT 1/2-12 X 1-1/2
5112	PSB04	CAP SCREW 1/4-20 X 1/2
5114	P9962Z5114	GREASE FITTING W/ CAP
5115	P9962Z5115	45° GREASE FITTING W/CAP
5116	P9962Z5116	PLUG
5118	PS04	PHLP HD SCR 1/4-20 X 1/2
5203	PSS02M	SET SCREW M6-1.0 X 6
5104	P05825204	BEARING UCC205
5205	P9962Z5205	HANDLE
5206	P9962Z5206	ROLLER LOCKDOWN SHAFT
5301	P05825301	BRACKET MALE (G0582/G0445)
5302	P05825302	BRACKET FEMALE (G0582/G0445)
5303	P05825303	FELT PAD (G0582/G0445)
5304	P05825304	GRAPHITE (G0582/G0445)
5305	PS01	PHLP HD SCR 10-24 X 1/2
5306	P05825306	PLATE (G0582/G0445)
5307	P05825307	BRACKET BASE (G0582/G0445)
5308	P05825308	BRACKET SHAFT (G0582/G0445)
5309	P05825309	LOCK COLLAR (G0582/G0445)
5310	PSS03	SET SCREW 1/4-20 X 3/8 (G0582/G0445)
5311	P05825311	KEY 1/4-20 X 25 (G0582/G0445)
5312	P05825312	COMPRESSION SPRING (G0582/G0445)
5313	P05825313	HOUSING (G0582/G0445)
5314	P05825314	BRACKET SHAFT (G0582/G0445)

REF	PART #	DESCRIPTION
5315	PSB16	CAP SCREW 3/8-16 X 3/4 (G0582/G0445)
5316	PW02	FLAT WASHER 3/8 (G0582/G0445)
5317	PW02	FLAT WASHER 3/8 (G0582/G0445)
5318	P05825318	HANDLE (G0582/G0445)
5319	PSS08	SET SCREW 5/16-18 X 1/2
5320	P05825320	ADJUSTMENT RING (G0582/G0445)
5321	PB03	HEX BOLT 5/16-18 X 1 (G0582/G0445)
5322	PW07	FLAT WASHER 5/16 (G0582/G0445)
5323	P05825323	HANDLE (G0582/G0445)
5401	P05825401	HOUSING (G0582/G0445)
5401	P9962Z5401	HOUSING (G9962Z/G9962ZX)
5402	P05825402	ROLLER (G0582/G0445)
5402	P9962Z5402	ROLLER (G9962Z/G9962ZX)
5403	P9962Z5403	FASTENING TUBE
5405	P05825405	PULLEY (G0582/G0445)
5405	P9962Z5405	PULLEY(G9962Z/G9962ZX)
5406	PSB11	CAP SCREW 5/16-18 X 1-1/4
5407	P05825407	HOUSING (G0582/G0445)
5407	P9962Z5407	HOUSING (G9962Z/G9962ZX)
5408	P9962Z5408	BRACKET PAD (G9962Z/G9962ZX)
5408	P05825408	BRACKET PAD (G0582/G0445)
5409	P6205	BEARING 6205-2RS
5410	P9962Z5410	COLLAR
5411	P9962Z5411	BEARING CAP
5417	P05825417	COVER (G0582/G0445)
5417	P9962Z5417	COVER (G9962Z/G9962ZX)



# Upper Roller System Diagram

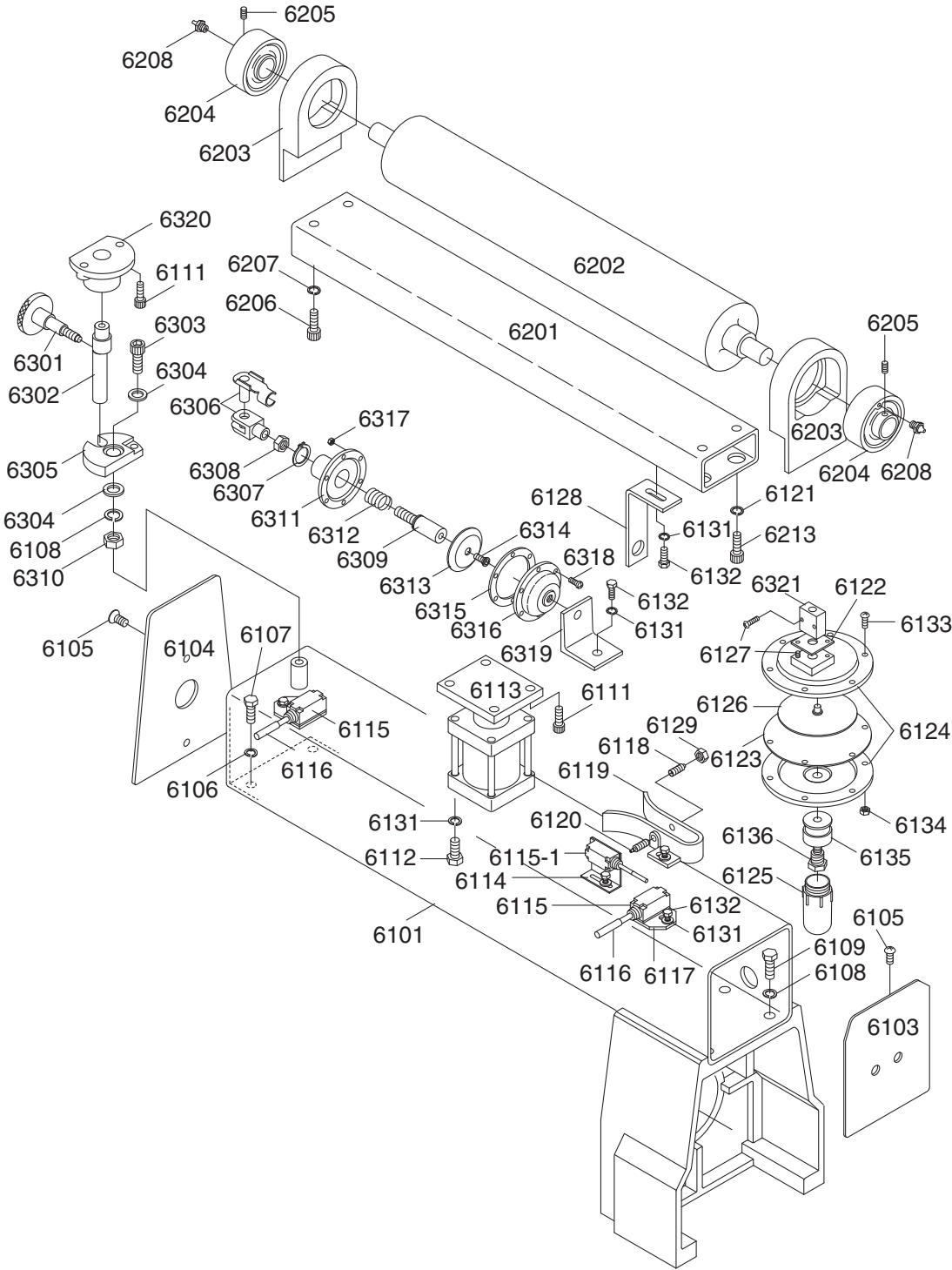

# Upper Roller System Parts List

REF	PART #	DESCRIPTION
6101	P04456101	SQUARE FRAME (G0445)
6101	P9962Z6101	SQUARE FRAME (G9962Z/G9962ZX/G0582)
6103	P04456103	FRAME SEAL (RIGHT) (G0445)
6103	P9962Z6103	FRAME SEAL (RIGHT) (G9962Z/G9962ZX/G0582)
6104	P04456104	FRAME SEAL (LEFT) (G0445)
6104	P9962Z6104	FRAME SEAL (LEFT) (G9962Z/G9962ZX/G0582)
6105	PFH05	FLAT HD SCR 1/4-20 X 3/4
6106	PLW04	LOCK WASHER 3/8
6107	PB18	HEX BOLT 3/8-16 X 1
6108	PLW07	LOCK WASHER 1/2
6109	PSB78	CAP SCREW 1/2-12 X 1
6111	PSB07	CAP SCREW 5/16-18 X 3/4
6112	PB09M	HEX BOLT M8-1.25 X 20
6113	P9962Z6113	AIR CYLINDER
6114	P9962Z6114	LIMIT SWITCH HOLDER (L TYPE)
6115	P9962Z6115	LIMIT SWITCH
6115-1	P9962Z6115-1	LIMIT SWITCH
6116	P9962Z6116	LIMIT SWITCH POST
6117	P9962Z6117	LIMIT SWITCH HOLDER
6118	P9962Z6118	AIR SENSOR NOZZLE (FEMALE)
6119	P9962Z6119	AIR CYLINDER BRACKET
6120	P9962Z6120	AIR SENSOR NOZZLE (MALE)
6121	PLW04	LOCK WASHER 3/8
6122	P9962Z6122	THROTTLE VALVE BASE
6123	P9962Z6123	PLATE
6124	P9962Z6124	ALUMINUM DISC
6125	P9962Z6125	OIL CAP
6126	P9962Z6126	ALUMINUM PLATE
6127	PS52M	PHLP HD SCR M4-0.7 X 20
6128	P9962Z6128	BRACKET
6129	PN11	HEX NUT 3/8-24
6131	PLW01	LOCK WASHER 5/16

REF	PART #	DESCRIPTION
6132	PB07	HEX BOLT 5/16-18 X 3/4
6133	PS08	PHLP HD SCR 10-24 X 3/4
6134	PN07	HEX NUT #10-24
6135	P9962Z6135	OIL CAP CONNECTOR
6136	P9962Z6136	OIL CAP SHAFT
6201	P9962Z6201	UPPER ROLLER BRACKET
6202	P9962Z6202	UPPER ROLLER
6203	P9962Z6203	UPPER ROLLER BRACKET
6204	P9962Z6204	BEARING UCC205
6205	PSS02M	SETSCREW M6-1.0 X 6
6206	PSB16	CAP SCREW 3/8-16 X 3/4
6207	PLW04	LOCK WASHER 3/8
6208	P9962Z6208	GREASE FITTING
6212	PSB16	CAP SCREW 3/8-16 X 3/4
6213	PLW04	LOCK WASHER 3/8
6301	P9962Z6301	FIRING ADJUSTER
6302	P9962Z6302	ECCENTRIC ROD
6303	PSB79	CAP SCREW 1/2-12 X 3-1/2
6304	PW01	FLAT WASHER 1/2
6305	P9962Z6305	ECCENTRIC PIECE
6306	P9962Z6306	UNIVERSAL JOINT FORK
6307	PR05M	EXT RETAINING RING 15MM
6308	PN02M	HEX NUT M10-1.5
6309	P9962Z6309	AIR CYLINDER SHAFT
6310	PN06	HEX NUT 1/2-12
6311	P9962Z6311	BOTTOM COVER
6312	P9962Z6312	SPRING
6313	P9962Z6313	ALUMINUM PLATE
6314	PS14M	PHLP HD SCR M6-1.0 X 12
6315	P9962Z6315	PLATE
6316	P9962Z6316	TOP COVER
6317	PN06M	HEX NUT M5-0.8
6318	PS20M	PHLP HD SCR M5-0.8 X 15
6319	P9962Z6319	AIR CYLINDER BRACKET
6320	P9962Z6320	ECCENTRIC SHAFT COLLAR
6321	P9962Z6321	VALVE ASSY.



# Cabinet Assembly Diagram

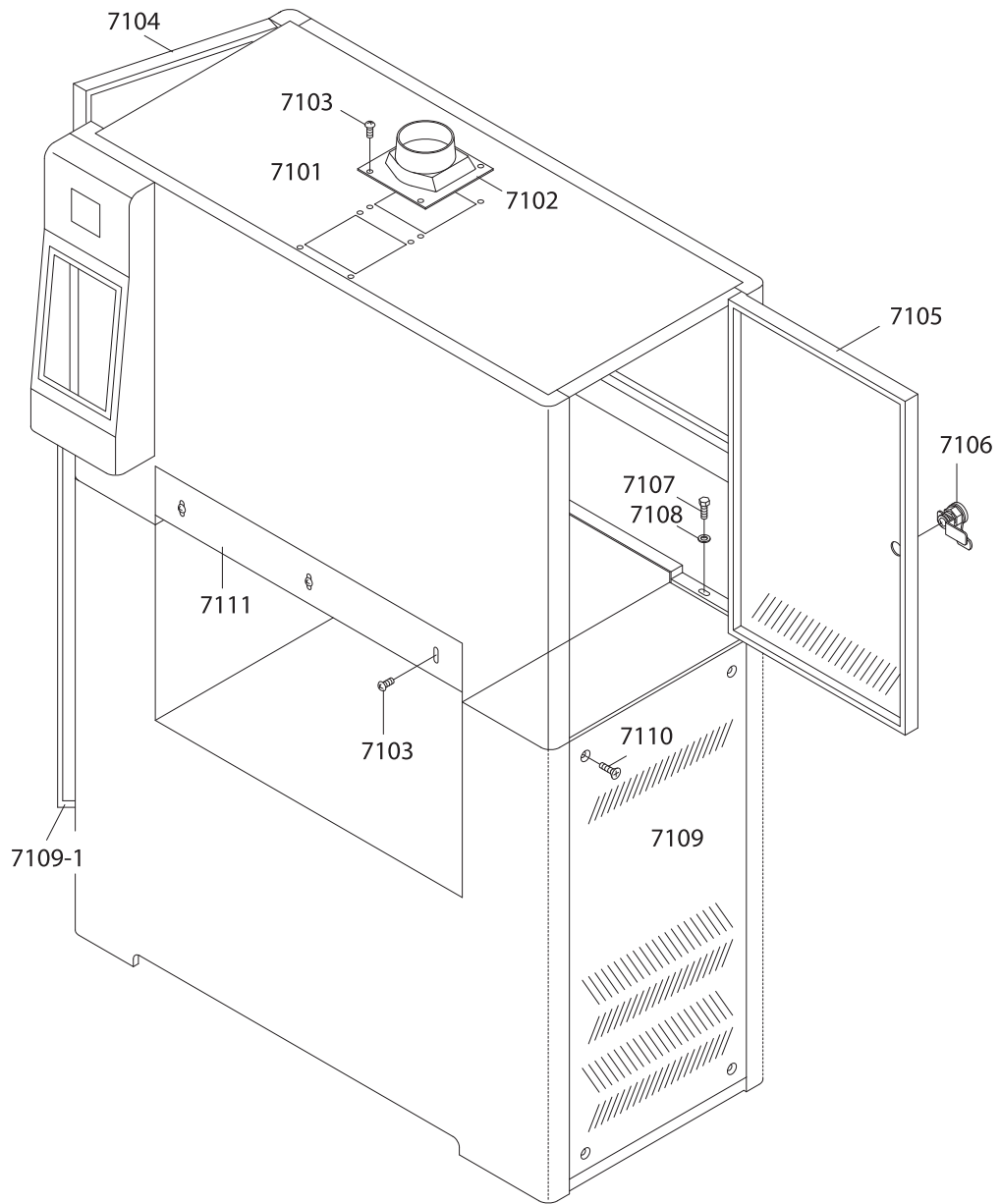

# Cabinet Assembly Parts List

REF	PART #	DESCRIPTION
7101	P9962Z7101	UPPER FRAME COVER (G9962Z/G9962ZX)
7101	P04457101	UPPER FRAME COVER (G0445)
7101	P05827101	UPPER FRAME COVER (G0582)
7102	P9962Z7102	DUST HOOD
7103	PS39M	PHLP HD SCR M6-1.0 X 10
7104	P9962Z7104	LEFT DOOR, UPPER FRAME (G9962Z/G9962ZX)
7104	P04457104	LEFT DOOR, UPPER FRAME (G0445)
7104	P05827104	LEFT DOOR, UPPER FRAME (G0582)
7105	P04457105	RIGHT DOOR, UPPER FRAME (G0445)

REF	PART #	DESCRIPTION
7105	P9962Z7105	RIGHT DOOR, UPPER FRAME (G9962Z/G9962ZX)
7105	P05827105	RIGHT DOOR, UPPER FRAME (G0582)
7106	P9962Z7106	DOOR LOCK
7107	PB03	HEX BOLT 5/16-18 X 1
7108	PW07	FLAT WASHER 5/16
7109	P9962Z7109	RIGHT DOOR, LOWER FRAME
7109-1	P9962Z7109-1	LEFT DOOR, LOWER FRAME
7110	PFH03	FLAT HD SCR 1/4-20 X 1/2
7111	P9962Z7111	FRONT PLATE



# Main Electrical Panel and Controls Diagram

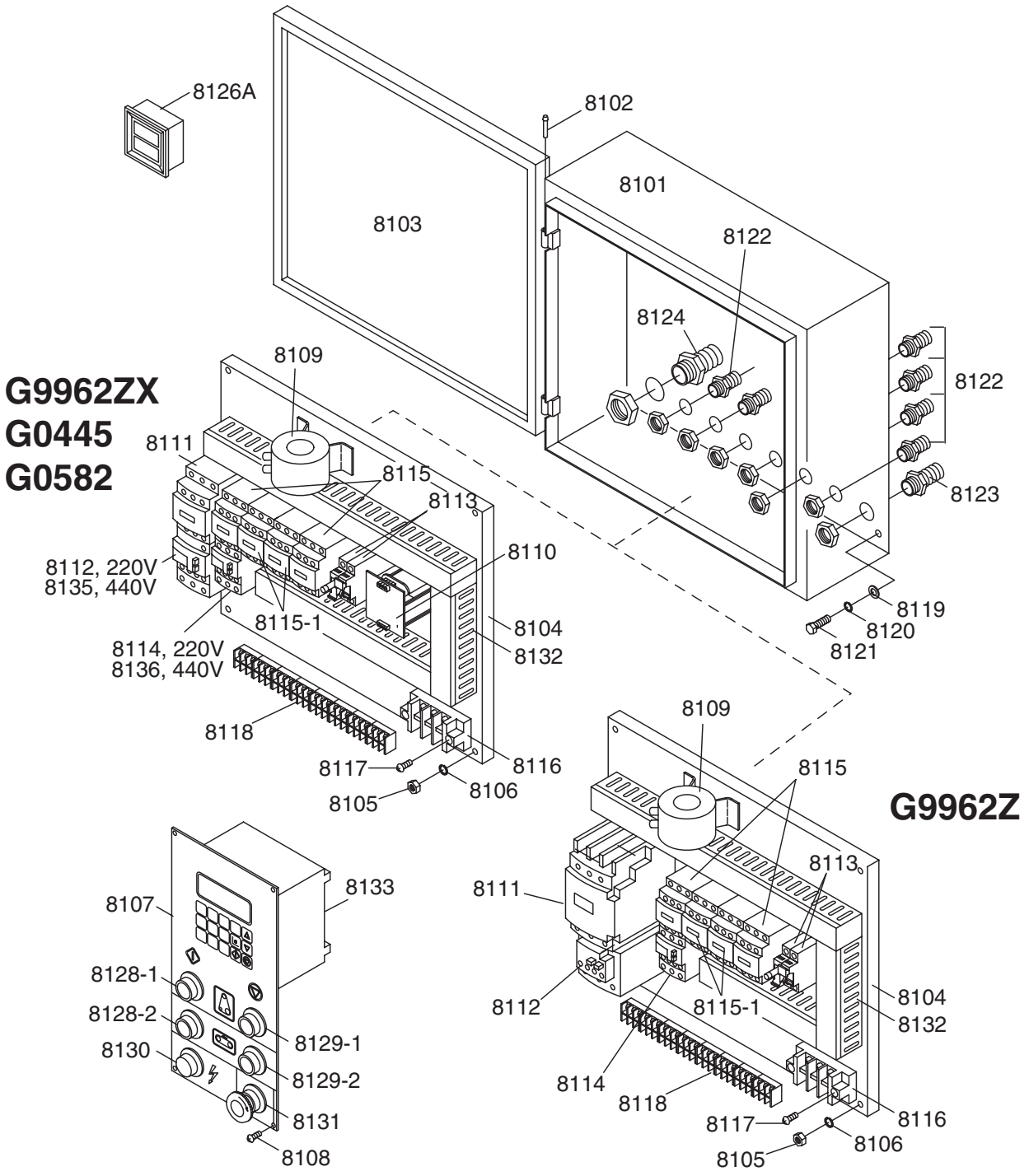

# Main Electrical Panel and Controls Parts List

REF	PART #	DESCRIPTION
8101	P9962Z8101	ELECTRICAL CONTROL BOX
8102	P9962Z8102	HINGE
8103	P9962Z8103	CONTROL BOX DOOR
8104	P9962Z8104	BASE PLATE
8105	PN05	HEX NUT 1/4-20
8106	PLW02	LOCK WASHER 1/4
8107	P9962Z8107	CONTROL PANEL
8108	PS07M	PHLP HD SCR M4-0.7 X 8
8109	P9962Z8109	AMP SENSOR (G9962Z)
8109	P9962ZX8109	AMP SENSOR (G0445/G9962ZX/G0582)
8110	P9962ZX8110	TRANSFOMER 220V/440V (G0445/G9962ZX/G0582)
8111	P9962Z8111	CONTACTOR LC1-D50 (G9962Z) 220V
8111	P9962ZX8111	CONTCTR LC1-D386 220V/440V (G0445/G9962ZX/G0582)
8112	P9962Z8112	OVRLD RELAY LR3D-3359 220V (48-65A SET TO 50A) (G9962Z)
8112	P9962ZX8112	OVRLD RELAY LR3D-326 220V (23-32A SET TO 25A) (G0445/G9962ZX/G0582)
8113	P9962Z8113	FUSE HOUSING
8113-1	P9962Z8113-1	FUSE 4 AMP
8114	P9962Z8114	OVRLD RELAY LR3D-126 220V (5.5-8A SET TO 7A)(G9962Z)

REF	PART #	DESCRIPTION
8114	P9962ZX8114	OVRLD RELAY LR3D-086 220V (2.5-4A SET TO 3.4A) (G0445/G9962ZX/G0582)
8115	P9962Z8115	CONTACTOR LC1-D096 220V/440V
8115-1	P9962Z8115-1	CONTACTOR (SET OF 2) LC1-D096 220V/440V
8116	P9962Z8116	POWER WIRE TERMINAL
8117	PS52M	PHLP HD SCR M4-0.7 X 30
8118	P9962Z8118	TERMINAL PLATE
8119	PW06	FLAT WASHER 1/4
8120	PLW02	LOCK WASHER 1/4
8121	PB26	HEX BOLT 1/4-20 X 1/2
8122	P9962Z8122	PU CONNECTOR 1/2
8123	P9962Z8123	PU CONNECTOR 3/4
8124	P9962Z8124	CABLE CONNECTOR 1
8126A	PH29338126A	DIGITAL AMP METER N/S
8128-1	P9962Z8128-1	START SWITCH
8128-2	P9962Z8128-2	START SWITCH
8129-1	P9962Z8129-1	STOP SWITCH
8129-2	P9962Z8129-2	STOP SWITCH
8130	P9962Z8130	POWER INDICATION LIGHT
8131	P9962Z8131	EMERGENCY STOP SWITCH
8132	P9962Z8132	WIRE COLUMN
8133	P9962Z8133	CPU

## G0445/G0582/G9962ZX 440V CONVERSION RELAYS

8135	P9962ZX8135	OVRLD RELAY LR3D-216 440V (12-18A SET TO 12.5A) (G0445/G9962ZX/G0582)
8136	P9962ZX8136	OVRLD RELAY LR3D-076 440V (1.6-2.5A SET TO 1.7A) (G0445/G9962ZX/G0582)



# Belt Oscillation System Diagram

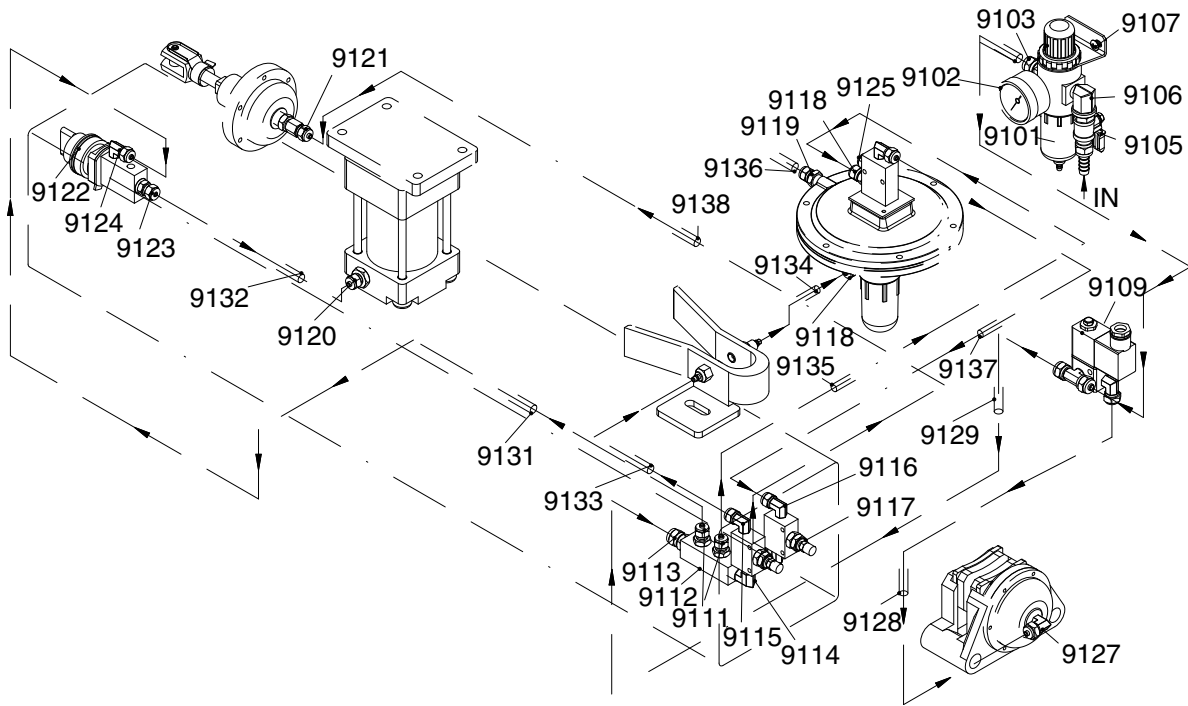

# Belt Oscillation System Parts List

REF	PART #	DESCRIPTION
9101	P9962Z9101	FILTER CUP
9102	P9962Z9102	PRESSURE REGULATOR
9103	P9962Z9103	BRONZE CONNECTOR
9105	P9962Z9105	AIR SWITCH
9106	P9962Z9106	ELBOW
9107	PS01	PHLP HD SCR 10-24 X 1/2
9109	P9962Z9109	SOLENOID VALVE
9111	P9962Z9111	PLASTIC CONNECTOR
9112	P9962Z9112	AIR MANIFOLD
9113	P9962Z9113	PLASTIC CONNECTOR
9114	P9962Z9114	ELBOW 1/4N X 1/4N X 90°
9115	P9962Z9115	CONNECTOR 1/4N X 1/8T X 90°
9116	P9962Z9116	CONNECTOR 1/4N X 1/8T X 90°
9117	P9962Z9117	THROTTLE VALVE
9118	P9962Z9118	PLASTIC CONNECTOR
9119	P9962Z9119	BRONZE ELBOW
9120	P9962Z9120	CONNECTOR 1/4N X 1/8T

REF	PART #	DESCRIPTION
9121	P9962Z9121	CONNECTOR 1/4N X 1/8T
9122	P9962Z9122	AIR SWITCH
9123	P9962Z9123	CONNECTOR 1/4N X 1/8T
9124	P9962Z9124	CONNECTOR 1/4N X 1/8T X 90°
9125	P9962Z9125	BUFFER
9127	P9962Z9127	CONNECTOR 1/4N X 1/8T X 90°
9128	P9962Z9128	8MM FLEXIBLE HOSE
9129	P9962Z9129	8MM FLEXIBLE HOSE
9131	P9962Z9131	6MM FLEXIBLE HOSE
9132	P9962Z9132	6MM FLEXIBLE HOSE
9133	P9962Z9133	6MM FLEXIBLE HOSE
9134	P9962Z9134	6MM FLEXIBLE HOSE
9135	P9962Z9135	6MM FLEXIBLE HOSE
9136	P9962Z9136	6MM FLEXIBLE HOSE
9137	P9962Z9137	6MM FLEXIBLE HOSE
9138	P9962Z9138	6MM FLEXIBLE HOSE



# Label Diagram

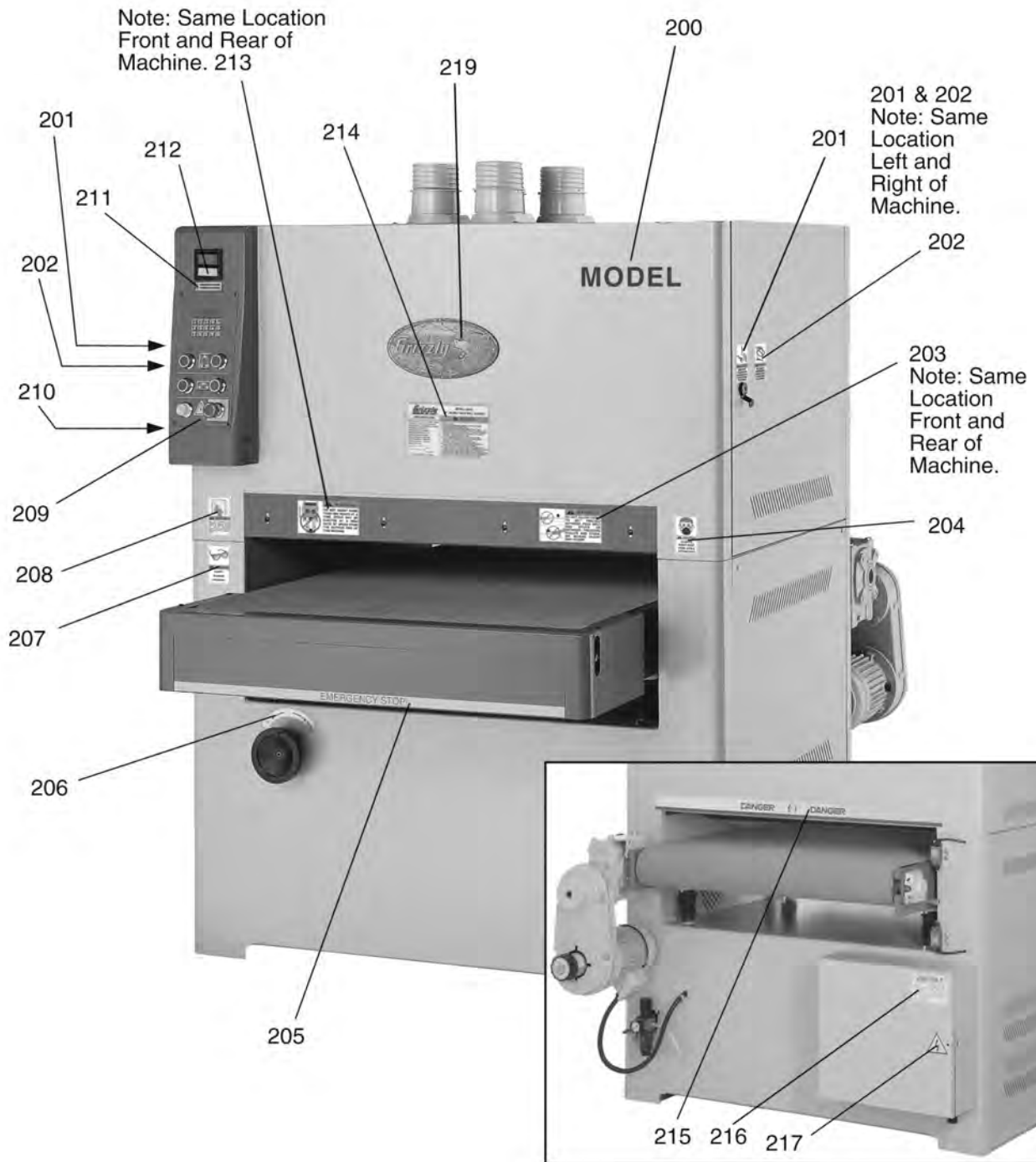

## **⚠️ WARNING**

Safety labels warn about machine hazards and ways to prevent injury. The owner of this machine **MUST** maintain the original location and readability of the labels on the machine. If any label is removed or becomes unreadable, **REPLACE** that label before using the machine again. Contact Grizzly at (800) 523-4777 or [www.grizzly.com](http://www.grizzly.com) to order new labels.



# Labels List

REF	PART #	DESCRIPTION
200	P9962Z200	LABEL (MODEL G9962Z)
200	P9962ZX200	LABEL (MODEL G9962ZX)
200	P0582200	LABEL (MODEL G0582)
200	P0445200	LABEL (MODEL G0445)
201	PLABEL-13	LABEL (UNPLUG)
202	PLABEL-30	LABEL (CLOSE DOOR)
203	PLABEL-22	LABEL (HAND PINCH)
204	PLABEL-32	LABEL (USE RESPIRATOR)
205	P9962Z205	LABEL (EMERGENCY STOP)
206	P0582206	LABEL (ROTATION)
207	PLABEL-35	LABEL (SAFETY GLASSES)
208	PLABEL-12	LABEL (READ MANUAL)
209	P9962Z209	LABEL (CONTROL PANEL)
210	PLABEL-27	LABEL (CONVERSION CHART)
211	P9962Z211	LABEL (AMP LOAD FOR G9962Z)

REF	PART #	DESCRIPTION
211	P9962ZX211	LABEL (AMP LOAD FOR G9962ZX)
211	P0582211	LABEL (AMP LOAD FOR G0582)
211	P0445211	LABEL (AMP LOAD FOR G0445)
212	P0582212	LABEL (AMP METER)
213	PLABEL-16	LABEL (SANDER KICKBACK)
214	P9962Z7112	LABEL (MACHINE DATA G9962Z)
214	P9962ZX7112	LABEL (MACHINE DATA G9962ZX)
214	P05827112	LABEL (MACHINE DATA G0582)
214	P04457112	LABEL (MACHINE DATA G0445)
215	P9962Z215	LABEL (DANGER STRIPE)
216	PLABEL-34	LABEL (PREWIRED FOR 220V)
216	P9962ZX215	LABEL (PREWIRED FOR 440V)
217	P9962217Z	LABEL (ELECTRICAL)
219	G8589	GRIZZLY LOGO PLATE



# Hardware Recognition Chart

USE THIS CHART TO MATCH UP  
HARDWARE DURING THE ASSEMBLY  
PROCESS!

MEASURE BOLT DIAMETER BY PLACING INSIDE CIRCLE

- #10
- 1/4"
- 5/16"
- 3/8"
- 7/16"
- 1/2"

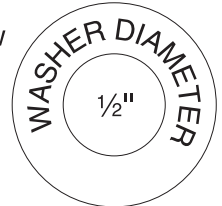
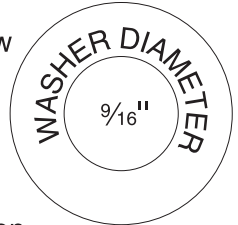
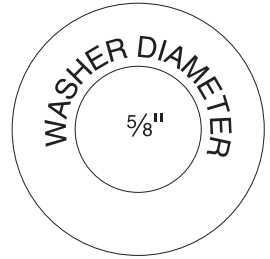
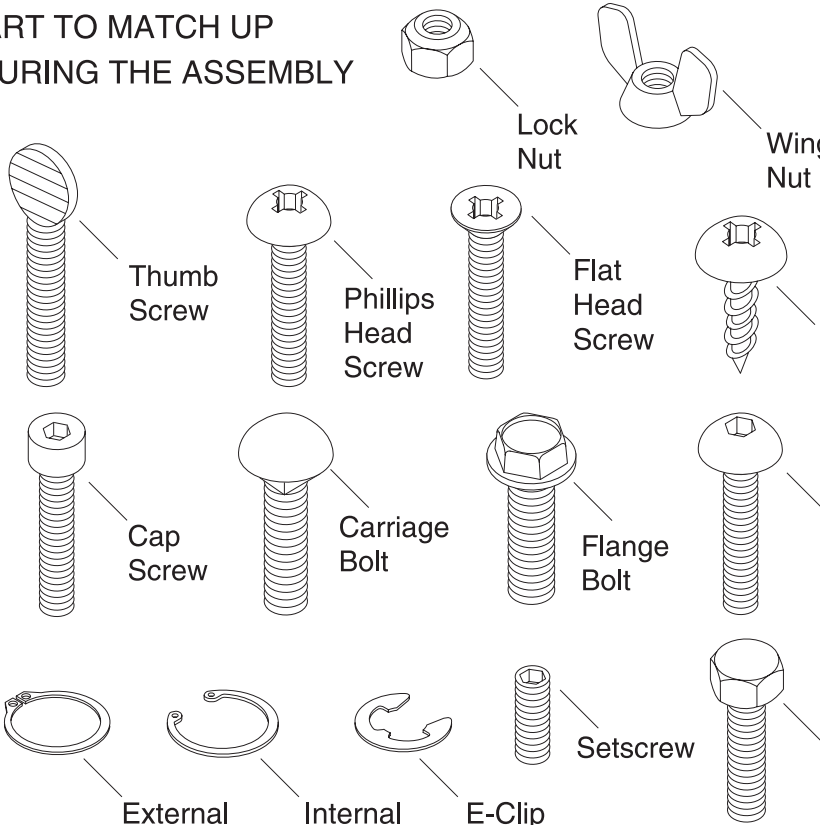

#10

- 4mm
- 6mm
- 8mm
- 10mm
- 12mm
- 16mm

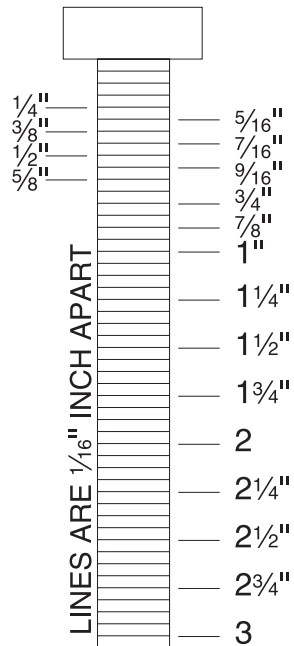
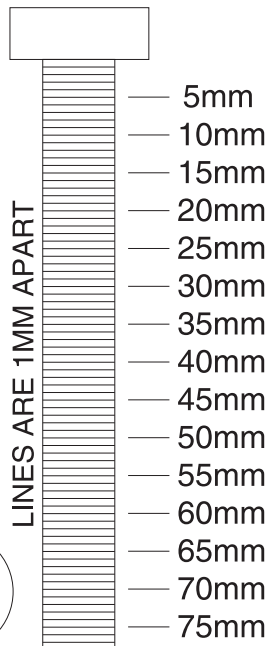

WASHERS ARE MEASURED BY THE INSIDE DIAMETER

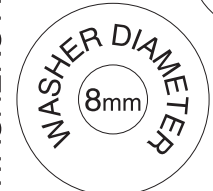
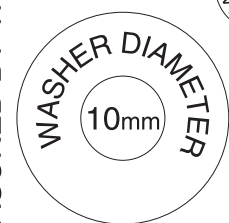
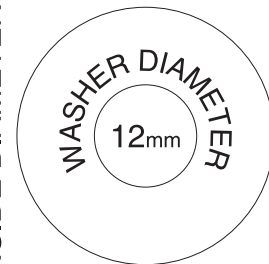

# Notes

---

---



# WARRANTY & RETURNS

---

---

Grizzly Industrial, Inc. warrants every product it sells for a period of **1 year** to the original purchaser from the date of purchase. This warranty does not apply to defects due directly or indirectly to misuse, abuse, negligence, accidents, repairs or alterations or lack of maintenance. This is Grizzly's sole written warranty and any and all warranties that may be implied by law, including any merchantability or fitness, for any particular purpose, are hereby limited to the duration of this written warranty. We do not warrant or represent that the merchandise complies with the provisions of any law or acts unless the manufacturer so warrants. In no event shall Grizzly's liability under this warranty exceed the purchase price paid for the product and any legal actions brought against Grizzly shall be tried in the State of Washington, County of Whatcom.

We shall in no event be liable for death, injuries to persons or property or for incidental, contingent, special, or consequential damages arising from the use of our products.

To take advantage of this warranty, contact us by mail or phone and give us all the details. We will then issue you a "Return Number," which must be clearly posted on the outside as well as the inside of the carton. We will not accept any item back without this number. Proof of purchase must accompany the merchandise.

The manufacturers reserve the right to change specifications at any time because they constantly strive to achieve better quality equipment. We make every effort to ensure that our products meet high quality and durability standards and we hope you never need to use this warranty.

Please feel free to write or call us if you have any questions about the machine or the manual.

Thank you again for your business and continued support. We hope to serve you again soon.





# WARRANTY CARD

Name \_\_\_\_\_

Street \_\_\_\_\_

City \_\_\_\_\_ State \_\_\_\_\_ Zip \_\_\_\_\_

Phone # \_\_\_\_\_ Email \_\_\_\_\_ Invoice # \_\_\_\_\_

Model # \_\_\_\_\_ Order # \_\_\_\_\_ Serial # \_\_\_\_\_

*The following information is given on a voluntary basis. It will be used for marketing purposes to help us develop better products and services. **Of course, all information is strictly confidential.***

**1. How did you learn about us?**

- Advertisement                       Friend                       Catalog
- Card Deck                               Website                       Other:

**2. Which of the following magazines do you subscribe to?**

- |   |  |   |
|---|--|---|
| <input type="checkbox"/> Cabinet Maker          | <input type="checkbox"/> Popular Mechanics   | <input type="checkbox"/> Today's Homeowner    |
| <input type="checkbox"/> Family Handyman        | <input type="checkbox"/> Popular Science     | <input type="checkbox"/> Wood                 |
| <input type="checkbox"/> Hand Loader            | <input type="checkbox"/> Popular Woodworking | <input type="checkbox"/> Wooden Boat          |
| <input type="checkbox"/> Handy                  | <input type="checkbox"/> Practical Homeowner | <input type="checkbox"/> Woodshop News        |
| <input type="checkbox"/> Home Shop Machinist    | <input type="checkbox"/> Precision Shooter   | <input type="checkbox"/> Woodsmith            |
| <input type="checkbox"/> Journal of Light Cont. | <input type="checkbox"/> Projects in Metal   | <input type="checkbox"/> Woodwork             |
| <input type="checkbox"/> Live Steam             | <input type="checkbox"/> RC Modeler          | <input type="checkbox"/> Woodworker West      |
| <input type="checkbox"/> Model Airplane News    | <input type="checkbox"/> Rifle               | <input type="checkbox"/> Woodworker's Journal |
| <input type="checkbox"/> Modeltec               | <input type="checkbox"/> Shop Notes          | <input type="checkbox"/> Other:               |
| <input type="checkbox"/> Old House Journal      | <input type="checkbox"/> Shotgun News        |   |

**3. What is your annual household income?**

- \$20,000-\$29,000                       \$30,000-\$39,000                       \$40,000-\$49,000
- \$50,000-\$59,000                       \$60,000-\$69,000                       \$70,000+

**4. What is your age group?**

- 20-29                                       30-39                                       40-49
- 50-59                                       60-69                                       70+

**5. How long have you been a woodworker/metalworker?**

- 0-2 Years                       2-8 Years                       8-20 Years                       20+ Years

**6. How many of your machines or tools are Grizzly?**

- 0-2                                       3-5                                       6-9                                       10+

**7. Do you think your machine represents a good value?**       Yes                       No

**8. Would you recommend Grizzly Industrial to a friend?**       Yes                       No

**9. Would you allow us to use your name as a reference for Grizzly customers in your area?**  
Note: *We never use names more than 3 times.*       Yes                       No

**10. Comments:** \_\_\_\_\_  
\_\_\_\_\_  
\_\_\_\_\_  
\_\_\_\_\_

CUT ALONG DOTTED LINE

FOLD ALONG DOTTED LINE

---

---

---



Place  
Stamp  
Here



GRIZZLY INDUSTRIAL, INC.  
P.O. BOX 2069  
BELLINGHAM, WA 98227-2069



FOLD ALONG DOTTED LINE

Send a Grizzly Catalog to a friend:

Name_____
Street_____
City_____ State_____ Zip_____

TAPE ALONG EDGES--PLEASE DO NOT STAPLE



# *grizzly.com*

**TOOL WEBSITE**

Buy Direct and Save with Grizzly® – Trusted, Proven and a Great Value!

*Visit Our Website Today And Discover  
Why Grizzly® Is The Industry Leader!*

- SECURE ORDERING
- ORDERS SHIPPED WITHIN 24 HOURS
- E-MAIL RESPONSE WITHIN ONE HOUR

-OR-

Call Today For A **FREE**  
Full Color Catalog

**1-800-523-4777**

