

# READ THIS FIRST

# Grizzly Industrial, Inc.®

**Models G0486 & G0487**  
**\*\*\*IMPORTANT UPDATE\*\*\***

For Machines Mfd. Since January, 2014  
and Owner's Manual Printed April, 2006

For questions or help with this product contact Tech Support at (570) 546-9663 or [techsupport@grizzly.com](mailto:techsupport@grizzly.com)

The following changes were made to this machine since the owner's manual was printed:

- Obtained CSA certification meeting CSA C22.2 #105-1953 and UL 987-7th standards.
- Changed transformer, contactors, overload relays, terminal blocks, 440V conversion kit components, and wiring.
- Changed circuit requirements.
- Replaced oscillation diaphragm assembly with an air cylinder.

**Note:** At the top of each page is a note that indicates which page it replaces in the original manual. On the parts list, the new parts are designated with a "V2".

Aside from this information, all other content in the owner's manual applies and **MUST** be read and understood for your own safety. **IMPORTANT: Keep this update with the owner's manual for future reference.** For questions or help, contact our Tech Support at (570) 546-9663 or [techsupport@grizzly.com](mailto:techsupport@grizzly.com).

## Electrical Cabinet Diagram (Only Replaces Electrical Cabinet Diagram on Page 64)

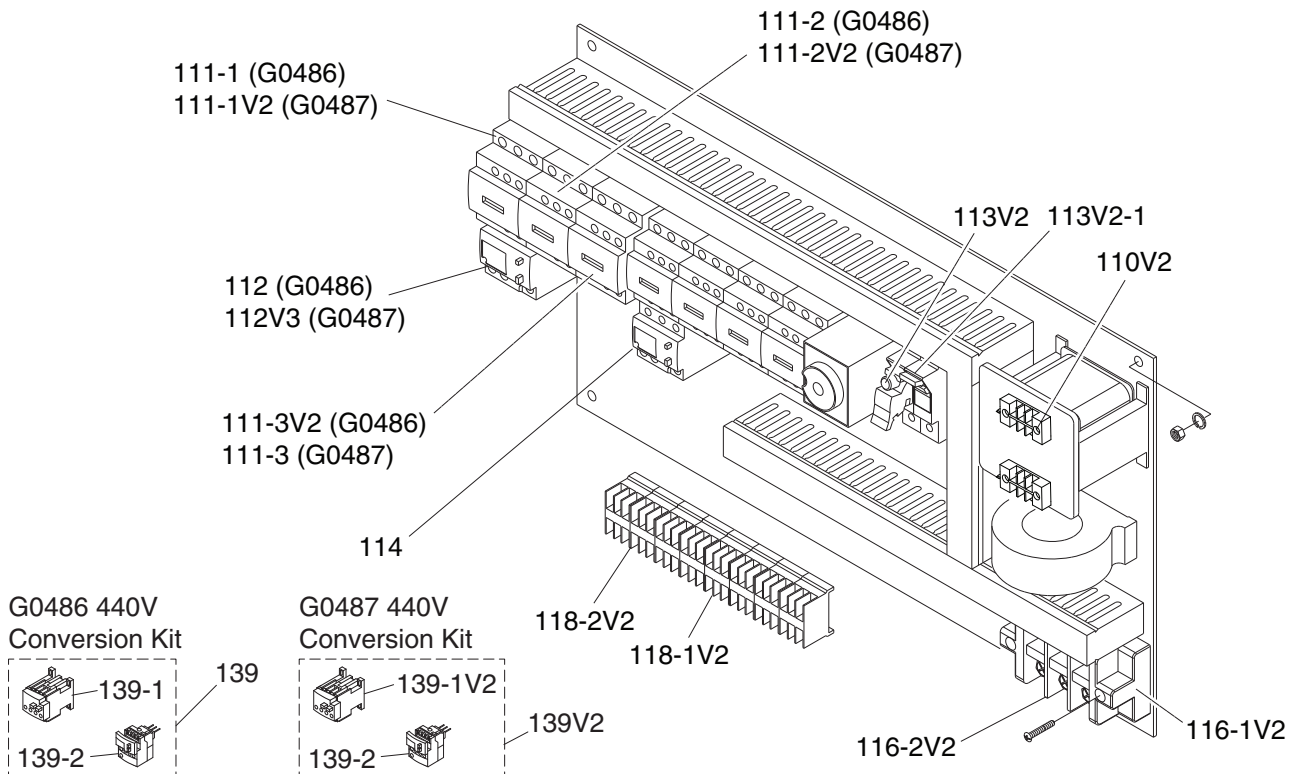

COPYRIGHT © NOVEMBER, 2014 BY GRIZZLY INDUSTRIAL, INC., REVISED MAY, 2014 (TS)  
**WARNING: NO PORTION OF THIS MANUAL MAY BE REPRODUCED IN ANY SHAPE OR FORM WITHOUT THE WRITTEN APPROVAL OF GRIZZLY INDUSTRIAL, INC.**  
#TS14577 PRINTED IN TAIWAN

**Only Replaces Electrical Cabinet Parts List on Page 65**  
**Electrical Cabinet Parts List**

**G0486 & G0487 220V Components**

REF	PART #	DESCRIPTION
110V2	P04868110V2	TRANSFORMER SUENN LIANG SP-TBS-20250 V2.10.11
111-1	P04868111-1	CONTACTOR SCHN LC1D38 220V
111-1V2	P04878111-1V2	CONTACTOR SCHN LC1D40A 220V V2.10.11
111-2	P04868111-2	CONTACTOR SCHN LC1D38 220V
111-2V2	P04878111-1V2	CONTACTOR SCHN LC1D40A 220V V2.10.11
111-3V2	P04868111-3V2	CONTACTOR SCHN LC1D25 220V V2.10.11
111-3	P04878111-3	CONTACTOR SCHN LC1D38 220V
112	P04868112	OL RELAY SCHN LR3D35 30-38A
112V3	P0539012V3	OL RELAY SCHN LRD340 30-40A V3.04.13
113V2	P04868113V2	FUSE CB KTK-4 10 X 38 550V 4A
113V2-1	P04868113V2-1	FUSE HOLDER SE DF101 10 X 38 V2.10.11
114	P05818114	OL RELAY SCHN LR3D12 5.5-8A
116-1V2	P04868116-1V2	TERMINAL PLATE ENTRELEC M16/12P YL/GRN V2.10.11
116-2V2	P04868116-2V2	TERMINAL PLATE ENTRELEC M16/12 GRAY V2.10.11
118-1V2	P04868118-1V2	TERMINAL PLATE ENTRELEC M4/6 GRAY V2.10.11
118-2V2	P04868118-2V2	TERMINAL PLATE ENTRELEC M4/6P YL/GRN V2.10.11

**G0486 440V Conversion Kit**

REF	PART #	DESCRIPTION
139	P04868139	440V CONVERSION KIT
139-1	PH29348134	OL RELAY SCHN LR3D21 12-18A
139-2	P04868139-2	OL RELAY SCHN LR3D08 2.5-4A

**G0487 440V Conversion Kit**

REF	PART #	DESCRIPTION
139V2	P04878139V2	440V CONVERSION KIT V2.10.11
139-1V2	P99809139A-1V2	OL RELAY SCHN LR3D325 17-25A V2.09.10
139-2	P04868139-2	OL RELAY SCHN LR3D08 2.5-4A



*Replaces Page 8*  
**SECTION 1: SAFETY**

---

## For Your Own Safety, Read Instruction Manual Before Operating This Machine

The purpose of safety symbols is to attract your attention to possible hazardous conditions. This manual uses a series of symbols and signal words intended to convey the level of importance of the safety messages. The progression of symbols is described below. Remember that safety messages by themselves do not eliminate danger and are not a substitute for proper accident prevention measures. Always use common sense and good judgment.



Indicates an imminently hazardous situation which, if not avoided, **WILL** result in death or serious injury.



Indicates a potentially hazardous situation which, if not avoided, **COULD** result in death or serious injury.



Indicates a potentially hazardous situation which, if not avoided, **MAY** result in minor or moderate injury. It may also be used to alert against unsafe practices.

***NOTICE***

This symbol is used to alert the user to useful information about proper operation of the machine.

## Safety Instructions for Machinery



**OWNER'S MANUAL.** Read and understand this owner's manual **BEFORE** using machine.

**TRAINED OPERATORS ONLY.** Untrained operators have a higher risk of being hurt or killed. Only allow trained/supervised people to use this machine. When machine is not being used, disconnect power, remove switch keys, or lock-out machine to prevent unauthorized use—especially around children. Make workshop kid proof!

**DANGEROUS ENVIRONMENTS.** Do not use machinery in areas that are wet, cluttered, or have poor lighting. Operating machinery in these areas greatly increases the risk of accidents and injury.

**MENTAL ALERTNESS REQUIRED.** Full mental alertness is required for safe operation of machinery. Never operate under the influence of drugs or alcohol, when tired, or when distracted.

**ELECTRICAL EQUIPMENT INJURY RISKS.** You can be shocked, burned, or killed by touching live electrical components or improperly grounded machinery. To reduce this risk, only allow qualified service personnel to do electrical installation or repair work, and always disconnect power before accessing or exposing electrical equipment.

**DISCONNECT POWER FIRST.** Always disconnect machine from power supply **BEFORE** making adjustments, changing tooling, or servicing machine. This prevents an injury risk from unintended startup or contact with live electrical components.

**EYE PROTECTION.** Always wear ANSI-approved safety glasses or a face shield when operating or observing machinery to reduce the risk of eye injury or blindness from flying particles. Everyday eyeglasses are **NOT** approved safety glasses.



## **WARNING**

**WEARING PROPER APPAREL.** Do not wear clothing, apparel or jewelry that can become entangled in moving parts. Always tie back or cover long hair. Wear non-slip footwear to avoid accidental slips, which could cause loss of workpiece control.

**HAZARDOUS DUST.** Dust created while using machinery may cause cancer, birth defects, or long-term respiratory damage. Be aware of dust hazards associated with each workpiece material, and always wear a NIOSH-approved respirator to reduce your risk.

**HEARING PROTECTION.** Always wear hearing protection when operating or observing loud machinery. Extended exposure to this noise without hearing protection can cause permanent hearing loss.

**REMOVE ADJUSTING TOOLS.** Tools left on machinery can become dangerous projectiles upon startup. Never leave chuck keys, wrenches, or any other tools on machine. Always verify removal before starting!

**USE CORRECT TOOL FOR THE JOB.** Only use this tool for its intended purpose—do not force it or an attachment to do a job for which it was not designed. Never make unapproved modifications—modifying tool or using it differently than intended may result in malfunction or mechanical failure that can lead to personal injury or death!

**AWKWARD POSITIONS.** Keep proper footing and balance at all times when operating machine. Do not overreach! Avoid awkward hand positions that make workpiece control difficult or increase the risk of accidental injury.

**CHILDREN & BYSTANDERS.** Keep children and bystanders at a safe distance from the work area. Stop using machine if they become a distraction.

**GUARDS & COVERS.** Guards and covers reduce accidental contact with moving parts or flying debris. Make sure they are properly installed, undamaged, and working correctly.

**FORCING MACHINERY.** Do not force machine. It will do the job safer and better at the rate for which it was designed.

**NEVER STAND ON MACHINE.** Serious injury may occur if machine is tipped or if the cutting tool is unintentionally contacted.

**STABLE MACHINE.** Unexpected movement during operation greatly increases risk of injury or loss of control. Before starting, verify machine is stable and mobile base (if used) is locked.

**USE RECOMMENDED ACCESSORIES.** Consult this owner's manual or the manufacturer for recommended accessories. Using improper accessories will increase the risk of serious injury.

**UNATTENDED OPERATION.** To reduce the risk of accidental injury, turn machine **OFF** and ensure all moving parts completely stop before walking away. Never leave machine running while unattended.

**MAINTAIN WITH CARE.** Follow all maintenance instructions and lubrication schedules to keep machine in good working condition. A machine that is improperly maintained could malfunction, leading to serious personal injury or death.

**CHECK DAMAGED PARTS.** Regularly inspect machine for any condition that may affect safe operation. Immediately repair or replace damaged or mis-adjusted parts before operating machine.

**MAINTAIN POWER CORDS.** When disconnecting cord-connected machines from power, grab and pull the plug—NOT the cord. Pulling the cord may damage the wires inside. Do not handle cord/plug with wet hands. Avoid cord damage by keeping it away from heated surfaces, high traffic areas, harsh chemicals, and wet/damp locations.

**EXPERIENCING DIFFICULTIES.** If at any time you experience difficulties performing the intended operation, stop using the machine! Contact our Technical Support at (570) 546-9663.



# Additional Safety for Wide Belt Sanders

## **WARNING**

Serious injury or death can occur from hands getting trapped between workpiece and conveyor table, getting entangled in rotating parts inside machine, or lacerated by sanding drum. Workpieces thrown by sander can strike nearby operators. Long-term respiratory damage can occur from using sander without proper use of a respirator and an adequate dust collection system. To minimize risk of getting hurt or killed, anyone operating machine **MUST** completely heed hazards and warnings below.

**FEEDING WORKPIECE.** DO NOT place fingers under bottom of workpiece while feeding it into sander. Fingers can become pinched between workpiece and conveyor.

**ENTANGLEMENT HAZARDS.** DO NOT wear loose clothing, gloves, or jewelry, and tie back long hair. Never reach inside operating machine or try clearing jammed workpiece. Keep all guards in place and secure, and all doors closed.

**SANDING DRUM CONTACT.** Rotating sandpaper can remove a large amount of flesh in a few seconds. Keep hands away from rotating sanding drum(s) during operation. Never touch moving sandpaper on purpose.

**WORKPIECE KICKBACK.** A workpiece can be ejected out the front of sander at high rate of speed, and hit operator or bystanders. Never stand in-line with workpiece, never feed more than one workpiece at a time, and always adjust pressure rollers below sanding roller.

**MINIMUM STOCK DIMENSION.** To avoid kick-back, never sand workpieces below minimum specifications listed in **Data Sheet**.

**ADJUSTMENTS/MAINTENANCE.** Make sure machine is turned **OFF**, disconnected from power and air, and all moving parts are completely stopped before doing adjustments or maintenance.

**SANDING DUST.** Sanding creates large amounts of dust and flying chips that can lead to eye injury or respiratory illness. Reduce risk of these hazards by wearing approved eye and respiratory protection when using sander.

**DUST COLLECTION.** Never operate without adequate dust collection system in place and running. Proper dust collection reduces dust in work area, which decreases risk of long-term respiratory damage, but it is not a substitute for using a respirator.

## **WARNING**

Like all machinery there is potential danger when operating this machine. Accidents are frequently caused by lack of familiarity or failure to pay attention. Use this machine with respect and caution to decrease the risk of operator injury. If normal safety precautions are overlooked or ignored, serious personal injury may occur.

## **CAUTION**

No list of safety guidelines can be complete. Every shop environment is different. Always consider safety first, as it applies to your individual working conditions. Use this and other machinery with caution and respect. Failure to do so could result in serious personal injury, damage to equipment, or poor work results.



# SECTION 2: POWER SUPPLY

## Availability

Before installing the machine, consider the availability and proximity of the required power supply circuit. If an existing circuit does not meet the requirements for this machine, a new circuit must be installed. To minimize the risk of electrocution, fire, or equipment damage, installation work and electrical wiring must be done by an electrician or qualified service personnel in accordance with all applicable codes and standards.

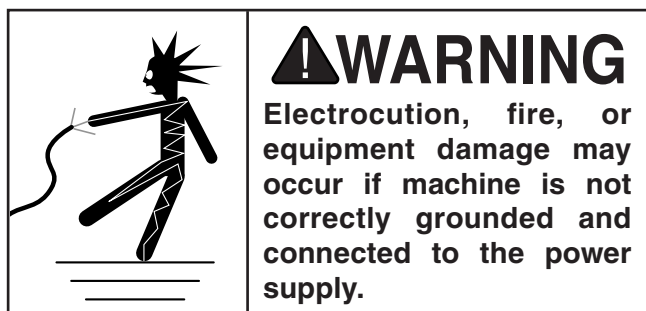

## Full-Load Current Rating

The full-load current rating is the amperage a machine draws at 100% of the rated output power. On machines with multiple motors, this is the amperage drawn by the largest motor or sum of all motors and electrical devices that might operate at one time during normal operations.

### G0486:

**Full-Load Current Rating at 220V .. 61.2 Amps**

**Full-Load Current Rating at 440V .. 30.6 Amps**

### G0487:

**Full-Load Current Rating at 220V .. 75.2 Amps**

**Full-Load Current Rating at 440V .. 37.6 Amps**

The full-load current is not the maximum amount of amps that the machine will draw. If the machine is overloaded, it will draw additional amps beyond the full-load rating.

If the machine is overloaded for a sufficient length of time, damage, overheating, or fire may result—especially if connected to an undersized circuit. To reduce the risk of these hazards, avoid overloading the machine during operation and make sure it is connected to a power supply circuit that meets the requirements in the following section.

## Circuit Information

A power supply circuit includes all electrical equipment between the breaker box or fuse panel in the building and the machine. The power supply circuit used for this machine must be sized to safely handle the full-load current drawn from the machine for an extended period of time. (If this machine is connected to a circuit protected by fuses, use a time delay fuse marked D.)



## In Addition to Page 11

**Note:** The circuit requirements listed in this manual apply to a dedicated circuit—where only one machine will be running at a time. If this machine will be connected to a shared circuit where multiple machines will be running at the same time, consult a qualified electrician to ensure that the circuit is properly sized for safe operation.

### G0486 220V Circuit Requirements

This machine is prewired to operate on a 220V power supply circuit that has a verified ground and meets the following requirements:

**Nominal Voltage** ..... 220V, 230V, 240V  
**Cycle** ..... 60 Hz  
**Phase** ..... 3-Phase  
**Circuit Rating** ..... 80 Amps

### G0486 440V Circuit Requirements

This machine can be converted to operate on a 440V power supply (refer to **Voltage Conversion** instructions) that has a verified ground and meets the following requirements:

**Nominal Voltage** ..... 440V, 480V  
**Cycle** ..... 60 Hz  
**Phase** ..... 3-Phase  
**Circuit Rating** ..... 40 Amps

### G0487 220V Circuit Requirements

This machine is prewired to operate on a 220V power supply circuit that has a verified ground and meets the following requirements:

**Nominal Voltage** ..... 220V, 230V, 240V  
**Cycle** ..... 60 Hz  
**Phase** ..... 3-Phase  
**Circuit Rating** ..... 100 Amps

### G0487 440V Circuit Requirements

This machine can be converted to operate on a 440V power supply (refer to **Voltage Conversion** instructions) that has a verified ground and meets the following requirements:

**Nominal Voltage** ..... 440V, 480V  
**Cycle** ..... 60 Hz  
**Phase** ..... 3-Phase  
**Circuit Rating** ..... 50 Amps

## Connection Type

A permanently connected (hardwired) power supply is typically installed with wires running through mounted and secured conduit. A disconnecting means, such as a locking switch (see following **Figure**), must be provided to allow the machine to be disconnected (isolated) from the power supply when required. This installation must be performed by an electrician in accordance with all applicable electrical codes and ordinances.

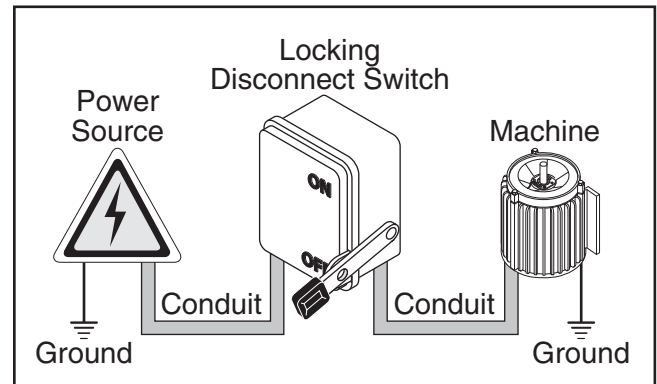

**Figure 1.** Typical setup of a permanently connected machine.

## Grounding Instructions

In the event of a malfunction or breakdown, grounding provides a path of least resistance for electrical current to reduce the risk of electric shock. A permanently connected machine must be connected to a grounded metal permanent wiring system; or to a system having an equipment-grounding conductor. All grounds must be verified and rated for the electrical requirements of the machine. Improper grounding can increase the risk of electric shock!

## **!WARNING**

**Serious injury could occur if you connect the machine to power before completing the setup process. DO NOT connect to power until instructed later in this manual.**

## Extension Cords

Since this machine must be permanently connected to the power supply, an extension cord cannot be used.



## Replaces Page 12

# 440V Conversion

To connect this machine to 440V three-phase, you must purchase a 440V Conversion Kit. Each machine requires a unique kit.

If you do not have three-phase power available for your wide belt sander, you must install a phase converter.

**Note:** When using a phase converter, the power from the manufactured power leg (sometimes called the wild wire) can fluctuate. Connect the manufactured power leg to the S terminal to prevent damage to the transformer. The wire from the S terminal can handle some fluctuation because it goes directly to the motor. The power going to the R and T terminals goes to the transformer and must be consistent to prevent damage.

### To convert sander to 440V:

1. DISCONNECT SANDER FROM POWER!
2. Open electrical cabinet located on back of machine.
3. On transformer, remove wire connected to the far right 220V terminal, and re-connect it to 440V terminal, as shown in **Figure 7**.

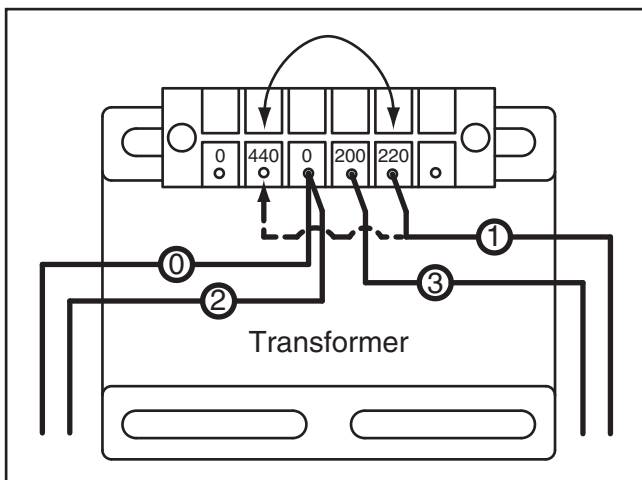

**Figure 7.** 440V transformer connection.

4. Swap out sanding and conveyor motor thermal overload relays from the 440V conversion kit at locations shown in **Figure 8**.

**Note:** To order a 440V conversion kit, contact Customer Service at (800) 523-4777.

—For the G0486, order Part Number P04868139, which includes:

Sanding Motor Relay LR3D21  
(Set amperage dial to 17A)

Conveyor Motor Relay LR3D08  
(Set amperage dial to 3A)

—For the G0487, order Part Number P04878139V2, which includes:

Sanding Motor Relay LR3D325  
(Set amperage dial to 18A)

Conveyor Motor Relay LR3D08  
(Set amperage dial to 3A)

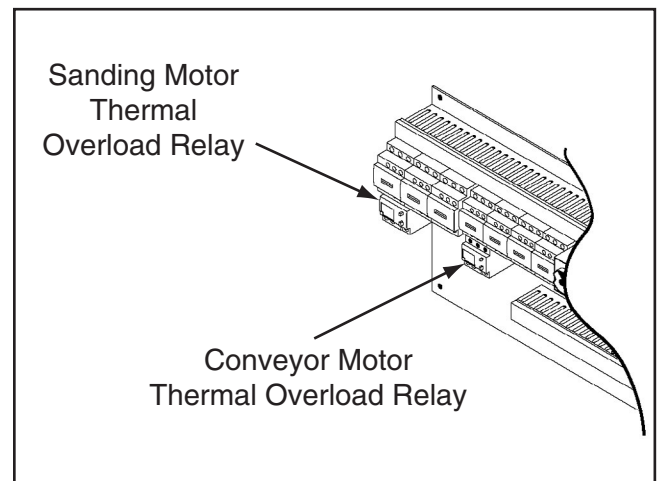

**Figure 8.** Location of 440V conversion components.

5. Wire the sanding belt, conveyor belt, and table elevation motors as shown on **Motor Wiring** diagrams on **Page 47** of your Owner's Manual.



# Replaces Page 41

## General Wiring Diagram

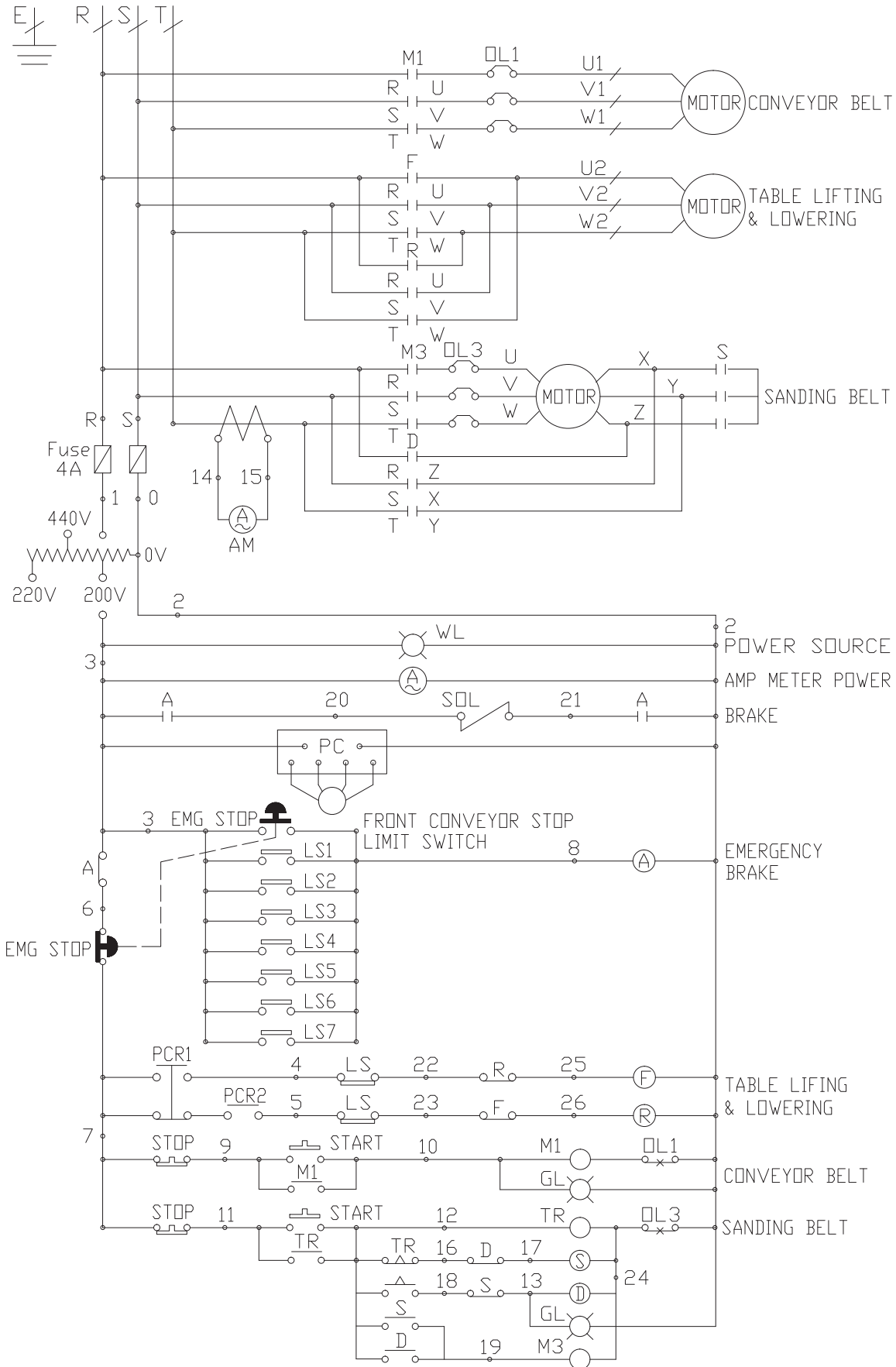

Replaces Pages 42 & 44

# Electrical Cabinet Wiring Diagram

**NOTICE**  
To rewire for 440V operation, refer to  
440V Conversion on Page 8.

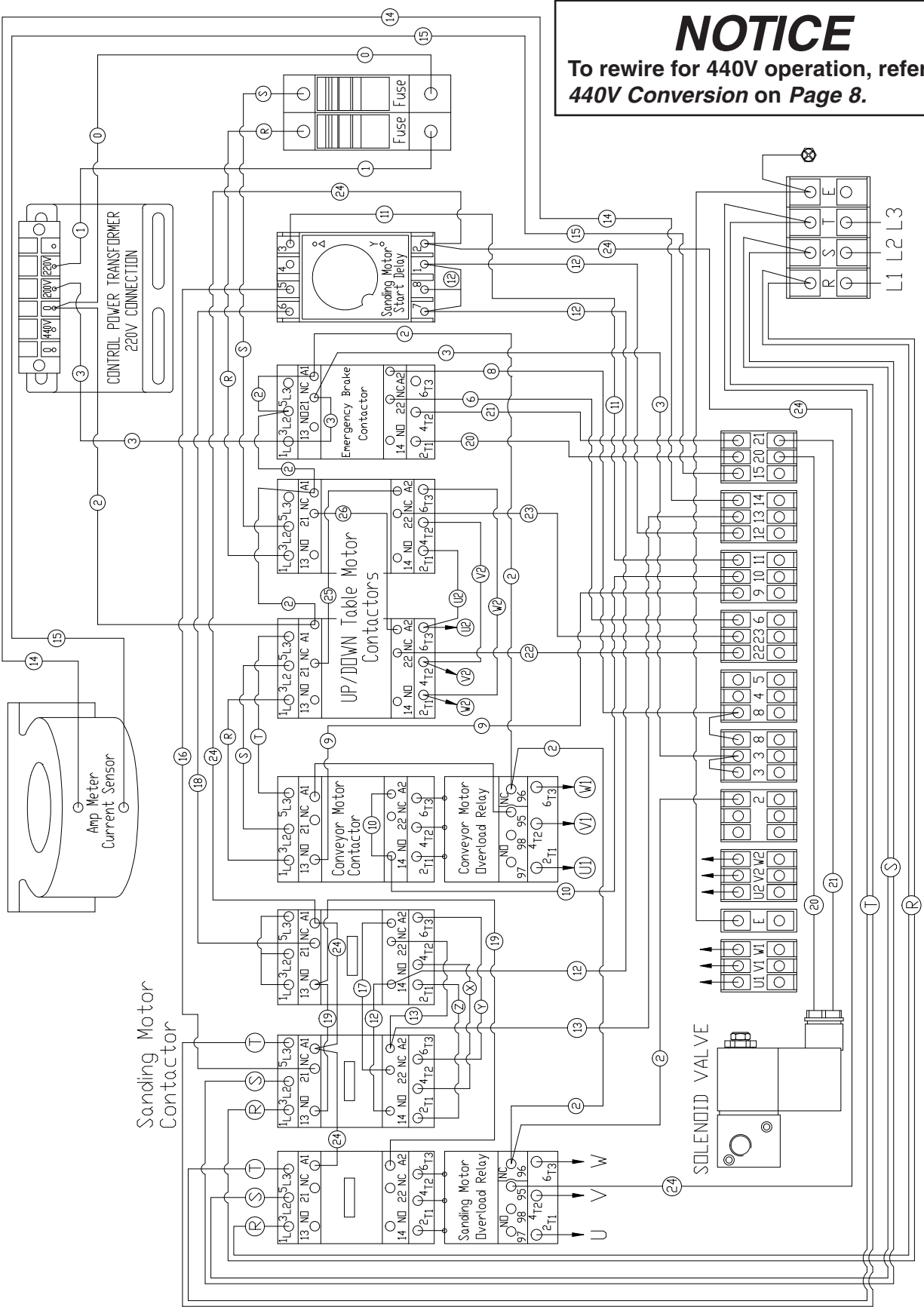

Replaces Page 60

# Upper Roller System Diagram

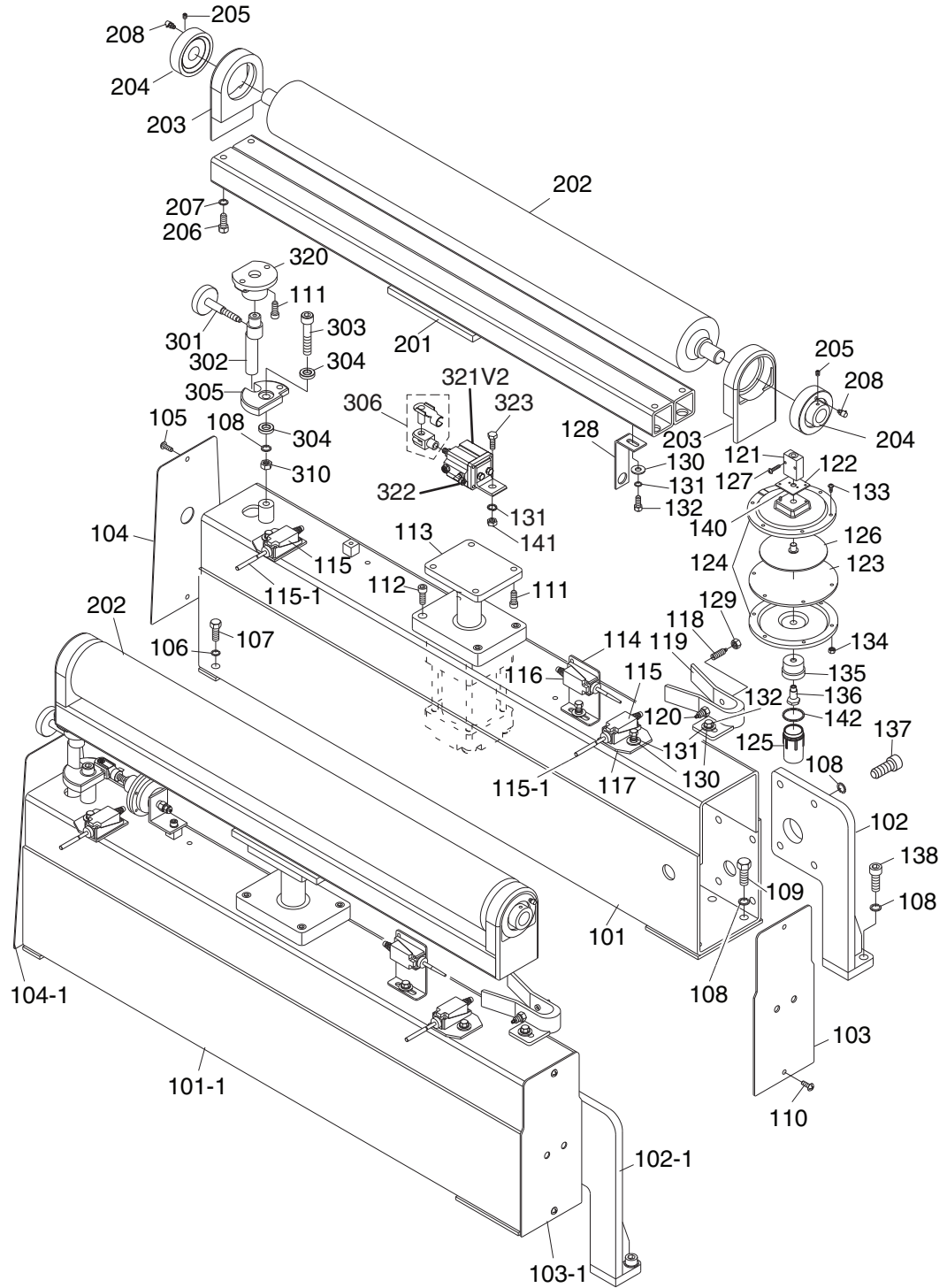

Previous Version Air Cylinder

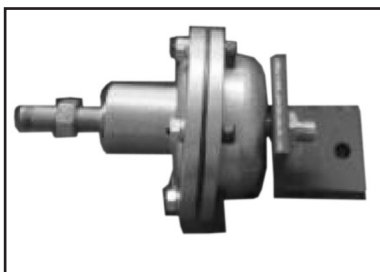

New Version Air Cylinder  
(Part No 321V2)

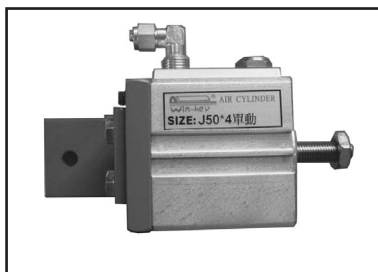

**Replaces Page 61**

# Upper Roller System Parts List

REF	PART #	DESCRIPTION
101	P04866101	SQUARE FRAME REAR (G0486)
101	P04876101	SQUARE FRAME REAR (G0487)
101-1	P04866101-1	SQUARE FRAME FRONT (G0486)
101-1	P04876101-1	SQUARE FRAME FRONT (G0487)
102	P04866102	REAR BRACKET (G0486)
102	P04876102	REAR BRACKET (G0487)
102-1	P04866102-1	FRONT BRACKET (G0486)
102-1	P04876102-1	FRONT BRACKET (G0487)
103	P04866103	FRAME SEAL RIGHT (G0486)
103	P04876103	FRAME SEAL RIGHT (G0487)
103-1	P04866103-1	FRAME SEAL FRNT RIGHT (G0486)
103-1	P04876103-1	FRAME SEAL FRNT RIGHT (G0487)
104	P04866104	FRAME SEAL LEFT (G0486)
104	P04876104	FRAME SEAL LEFT (G0487)
104-1	P04866104-1	FRAME SEAL FRNT LEFT (G0486)
104-1	P04876104-1	FRAME SEAL FRNT LEFT (G0487)
105	PFH03	FLAT HD SCR 1/4-20 X 1/2
106	PLW04	LOCK WASHER 3/8
107	PB18	HEX BOLT 3/8-16 X 1
108	PLW07	LOCK WASHER 1/2
109	PB40	HEX BOLT 1/2-12 X 1-1/4
110	PS04	PHLP HD SCR 1/4-20 X 1/2
111	PSB07	CAP SCREW 5/16-18 X 3/4
112	PB03	HEX BOLT 5/16-18 X 1
113	P04866113	AIR CYLINDER
114	P04866114	LIMIT SWITCH HOLDER L-TYPE
115	P04866115	LIMIT SWITCH W/CERAMIC TIP
115-1	P04866115-1	CERAMIC TIP
116	P04866116	LIMIT SWITCH W/PLASTIC TIP
117	P04866117	LIMIT SWITCH HOLDER
118	P04866118	AIR SENSOR NOZZLE FEMALE
119	P04866119	AIR FORK
120	P04866120	AIR SENSOR NOZZLE MALE
121	P04866121	THROTTLE VALVE
122	P04866122	THROTTLE VALVE BASE
123	P04866123	DIAPHRAGM
124	P04866124	HOUSING ASSEMBLY
125	P04866125	OIL CAP

REF	PART #	DESCRIPTION
126	P04866126	ALUMINUM PLATE
127	PS02M	PHLP HD SCR M4-.7 X 12
128	P04866128	SHUTDOWN BRACKET
129	PN11	HEX NUT 3/8-24
130	PW07	FLAT WASHER 5/16
131	PLW01	LOCK WASHER 5/16
132	PB09	HEX BOLT 5/16-18 X 1/2
133	PS08	PHLP HD SCR 10-24 X 3/4
134	PN07	HEX NUT 10-24
135	P04866135	CONNECTOR OF OIL CAP
136	P04866136	SHAFT OF OIL CAP
137	PSB76	CAP SCREW 1/2-12 X 1-1/2
138	PB53	HEX BOLT 1/2-12 X 1
140	PFH25M	FLAT HD SCR M4-.7 X 12
141	PN02	HEX NUT 5/16-18
142	P04866142	O-RING
201	P04866201	UPPER ROLLER BRACKET (G0486)
201	P04876201	UPPER ROLLER BRACKET (G0487)
202	P05816202	UPPER ROLLER (G0486)
202	P04876202	UPPER ROLLER (G0487)
203	P04866203	UPPER ROLLER BRACKET
204	P05275104	CYL. CARTRIDGE BEARING UCC205
205	PSS02M	SET SCREW M6-1 X 6
206	PSB16	CAP SCREW 3/8-16 X 3/4
207	PLW04	LOCK WASHER 3/8
208	P04866208	GREASE FITTING W/DUST CAP
301	P05816301	TRIMMING SCREW 2 X 90MM
302	P04866302	ECCENTRIC ROD
303	PBS98	CAP SCREW 1/2-12 X 2-3/4
304	PW01	FLAT WASHER 1/2
305	P04866305	ECCENTRIC PIECE
306	P04866306	CLEVIS ASSEMBLY
310	PN06	HEX NUT 1/2-12
320	P04866320	ECCENTRIC SHAFT FRAME
321V2	P04866321V2	OSCILLATING AIR CYLINDER V2.01.14
322	P04866322	CONNECTOR 1/4N X 1/4T 90°
323	PB11	HEX BOLT 5/16-18 X 1-1/2



Replaces Page 66 & 67

# Belt Oscillation System

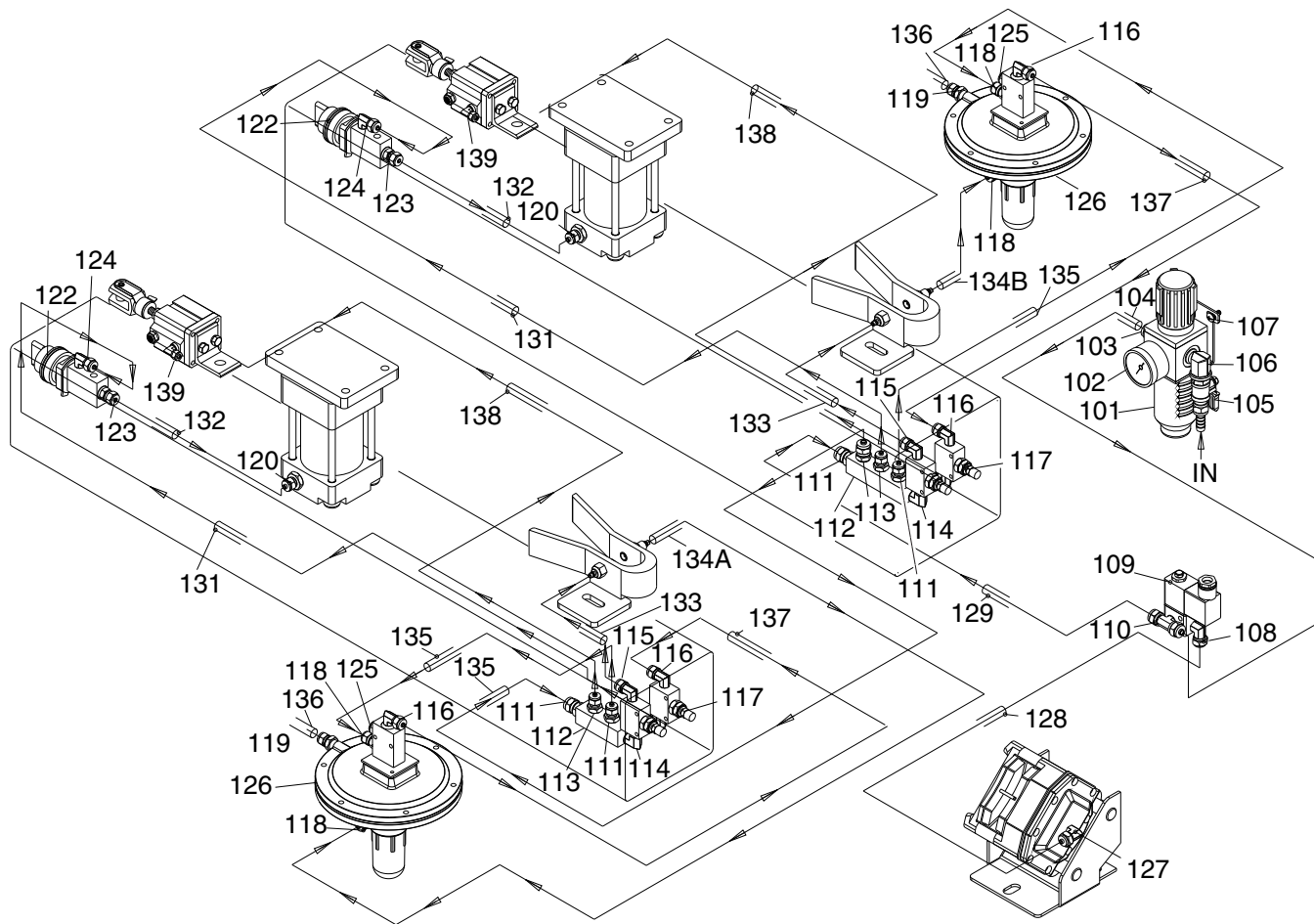

REF	PART #	DESCRIPTION
101	PH29339101	FILTER CUP
102	PH29339102	PRESSURE REGULATOR W/GAUGE
103	PH29339103	BRONZE CONNECTOR 5/16N X 1/4T
104	PH29339104	8 X 900MM FLEXIBLE HOSE
105	PH29339105	AIR VALVE 1/4"
106	PH29339106	ELBOW 1/4T X 1/4T 90°
107	PS22	PHLP HD SCR 10-24 X 5/8
108	PH29339108	ELBOW 5/16N X 1/8T 90°
109	PH29339109	SOLENOID VALVE
110	PH29339110	T-FITTING 5/16N X 5/16N X 1/8T
111	PH29339111	CONNECTOR 1/4N X 1/4T
112	PH29339112	MANIFOLD 1/4N
113	P04869113	CONNECTOR 5/16N X 1/4T
114	P04869114	BRONZE ELBOW 1/4T X 1/8T-90
115	PH29339115	CONNECTOR 1/4N X 1/8T 90°
116	PH29339116	CONNECTOR 1/4N X 1/8T 90°
117	PH29339117	THROTTLE VALVE 1/8"
118	P04869118	CONNECTOR 1/4N X 1/8T
119	P04869119	BRONZE CONNECTOR 1/4N
120	P04869120	CONNECTOR 1/4N X 3/8T
122	PH29339122	AIR SWITCH 1/8"

REF	PART #	DESCRIPTION
123	PH29339123	CONNECTOR 1/4N X 1/8T
124	PH29339124	CONNECTOR 1/4N X 1/8T 90°
125	P04869125	BUFFER 1/8"(BRONZE)
126	P04869126	DIAPHRAGM ASSEMBLY
127	PH29339127	CONNECTOR 5/16N X 1/8T 90°
128	PH29339128	8 X 900MM FLEXIBLE HOSE
129	PH29339129	8 X 1650MM FLEXIBLE HOSE
130	P04869130	6MM FLEXIBLE HOSE
131	P04869131	6 X 1700MM FLEXIBLE HOSE (G0486)
131	P04879131	6 X 1800MM FLEXIBLE HOSE (G0487)
132	P04869132	6 X 800MM FLEXIBLE HOSE (G0486)
132	P04879132	6 X 950MM FLEXIBLE HOSE (G0487)
133	PH29339133	6 X 600MM FLEXIBLE HOSE
134A	PH29339134	6 X 650MM FLEXIBLE HOSE FRONT
134B	PH29339134	6 X 300MM FLEXIBLE HOSE REAR
135	PH29339135	6 X 700MM FLEXIBLE HOSE
136	PH29339136	6 X 350MM FLEXIBLE HOSE
137	PH29339137	6 X 700MM FLEXIBLE HOSE
138	P04869138	6 X 1500MM FLEXIBLE HOSE (G0486)
138	P04879138	6 X 1700MM FLEXIBLE HOSE (G0487)
139	P04866322	CONNECTOR 1/4N X 1/4T 90°



# *grizzly.com*<sup>®</sup>

**TOOL WEBSITE**

Buy Direct and Save with Grizzly<sup>®</sup> – Trusted, Proven and a Great Value!  
~Since 1983~

*Visit Our Website Today For  
Current Specials!*

**ORDER  
24 HOURS A DAY!  
1-800-523-4777**



# *Grizzly* *Industrial, Inc.*®

## MODEL G0486/G0487 DOUBLE-HEAD WIDE-BELT SANDER OWNER'S MANUAL



COPYRIGHT © APRIL 2006 BY GRIZZLY INDUSTRIAL, INC.  
**WARNING: NO PORTION OF THIS MANUAL MAY BE REPRODUCED IN ANY SHAPE  
OR FORM WITHOUT THE WRITTEN APPROVAL OF GRIZZLY INDUSTRIAL, INC.**  
#BL7827 PRINTED IN TAIWAN

 **WARNING!**

**This manual provides critical safety instructions on the proper setup, operation, maintenance and service of this machine/equipment.**

**Failure to read, understand and follow the instructions given in this manual may result in serious personal injury, including amputation, electrocution or death.**

**The owner of this machine/equipment is solely responsible for its safe use. This responsibility includes but is not limited to proper installation in a safe environment, personnel training and usage authorization, proper inspection and maintenance, manual availability and comprehension, application of safety devices, blade/cutter integrity, and the usage of personal protective equipment.**

**The manufacturer will not be held liable for injury or property damage from negligence, improper training, machine modifications or misuse.**

 **WARNING!**

**Some dust created by power sanding, sawing, grinding, drilling, and other construction activities contains chemicals known to the State of California to cause cancer, birth defects or other reproductive harm. Some examples of these chemicals are:**

- **Lead from lead-based paints.**
- **Crystalline silica from bricks, cement and other masonry products.**
- **Arsenic and chromium from chemically-treated lumber.**

**Your risk from these exposures varies, depending on how often you do this type of work. To reduce your exposure to these chemicals: Work in a well ventilated area, and work with approved safety equipment, such as those dust masks that are specially designed to filter out microscopic particles.**

# Table of Contents

<b>INTRODUCTION</b> .....	<b>3</b>
Foreword .....	3
Contact Info.....	3
Control Panel Features .....	4
External Features .....	4
Internal Features .....	5
Machine Data Sheet (G0486) .....	6
Machine Data Sheet (G0487) .....	7
<b>SECTION 1: SAFETY</b> .....	<b>8</b>
Safety Instructions for Machinery.....	8
Additional Safety for Wide Belt Sanders.....	10
<b>SECTION 2: CIRCUIT REQUIREMENTS</b> .....	<b>11</b>
220V/440V Connection .....	11
Grounding.....	11
Amperage Loads.....	11
Extension Cords.....	11
440V Connection.....	12
<b>SECTION 3: SET UP</b> .....	<b>13</b>
Unpacking .....	13
Items Needed for Set Up .....	13
Inventory.....	13
Hardware Chart.....	14
Clean Up .....	15
Site Considerations .....	15
Beginning Assembly.....	16
Air Line Installation.....	16
Dust Collection .....	16
Sanding Belt.....	17
Pressure Rollers.....	18
Start Up .....	18
Recommended Adjustments .....	19
<b>SECTION 4: OPERATIONS</b> .....	<b>20</b>
Operation Safety .....	20
Choosing Sandpaper .....	20
Table Movement .....	21
Adjusting Feed Rate.....	21
Amp Draw Meter .....	22
Sanding Workpiece .....	23
Platen Adjustment.....	23
<b>SECTION 5: ACCESSORIES</b> .....	<b>24</b>
<b>SECTION 6: MAINTENANCE</b> .....	<b>25</b>
General.....	25
Schedule .....	25
Sanding Belts .....	26
Air System.....	26
Dust and Water Traps.....	26



<b>SECTION 7: SERVICE .....</b>	<b>27</b>
Table Calibration .....	27
Platen Service .....	27
Brake Service .....	28
Oscillation Timing .....	29
Oscillation Speed .....	31
Table Parallelism .....	31
Pressure Rollers .....	32
V-Belt Adjustment .....	33
Conveyor Belt Replacement .....	34
Feed Belt Tension .....	36
Feed Belt Tracking .....	36
Air System Diagram .....	37
Troubleshooting .....	38
Wiring Box Electrical Diagram (G0486 220V/440V, G0487 440V) .....	42
Wiring Box Components (G0486 220V/440V, G0487 440V) .....	43
Wiring Box Electrical Diagram (G0487 220V) .....	44
Wiring Box Components (G0487 220V) .....	45
General Electric Diagram(G0486/G0487) .....	46
Motor Wiring (G0486/G0487) .....	47
Tool Box and Accessories Diagram .....	48
Tool Box and Accessories Parts List .....	49
Sanding Motor System Diagram .....	50
Sanding Motor System Parts List .....	51
Table Lift System Diagram .....	52
Table Lift System Parts List .....	53
Conveyor System Diagram .....	54
Conveyor System Parts List .....	55
Feed, Drum, and Pressure Roller Diagram .....	56
Feed, Drum, and Pressure Roller Parts List .....	57
Sanding Drum and Platen Diagram .....	58
Sanding Drum and Platen Parts List .....	59
Upper Roller System Diagram .....	60
Upper Roller System Parts List .....	61
Cabinet Assembly Diagram .....	62
Main Electrical Panel and Controls Diagram .....	64
Main Electrical Panel and Controls Parts List .....	65
Air System Diagram .....	66
Air System Parts List .....	67
Machine Label Diagram .....	68
Machine Label List .....	69
<b>WARRANTY &amp; RETURNS .....</b>	<b>70</b>



# INTRODUCTION

---

---

## Foreword

---

---

We are proud to offer the G0486/G0487 Wide Belt Sander. This machine is part of a growing Grizzly family of fine woodworking machinery. When used according to the guidelines set forth in this manual, you can expect years of trouble-free, enjoyable operation and proof of Grizzly's commitment to customer satisfaction.

We are pleased to provide this manual with the G0486/G0487 Wide Belt Sander. It was written to guide you through assembly, review safety considerations, and cover general operating procedures.

The specifications, drawings, and photographs illustrated in this manual represent the G0486/G0487 Wide Belt Sander as supplied when the manual was prepared. For your convenience, we always keep current Grizzly manuals available on our website at [www.grizzly.com](http://www.grizzly.com). Any updates to your machine will be reflected in these manuals as soon as they are complete.

## Contact Info

---

---

If you have any comments regarding this manual, please write to us at the address below:

Grizzly Industrial, Inc.  
c/o Technical Documentation Manager  
P.O. Box 2069  
Bellingham, WA 98227-2069

We stand behind our machines. If you have any service questions or parts requests, please call or write us at the location listed below.

Grizzly Industrial, Inc.  
1203 Lycoming Mall Circle  
Muncy, PA 17756  
Phone: (570) 546-9663  
Fax: (800) 438-5901  
E-Mail: [techsupport@grizzly.com](mailto:techsupport@grizzly.com)  
Web Site: <http://www.grizzly.com>



# Control Panel Features

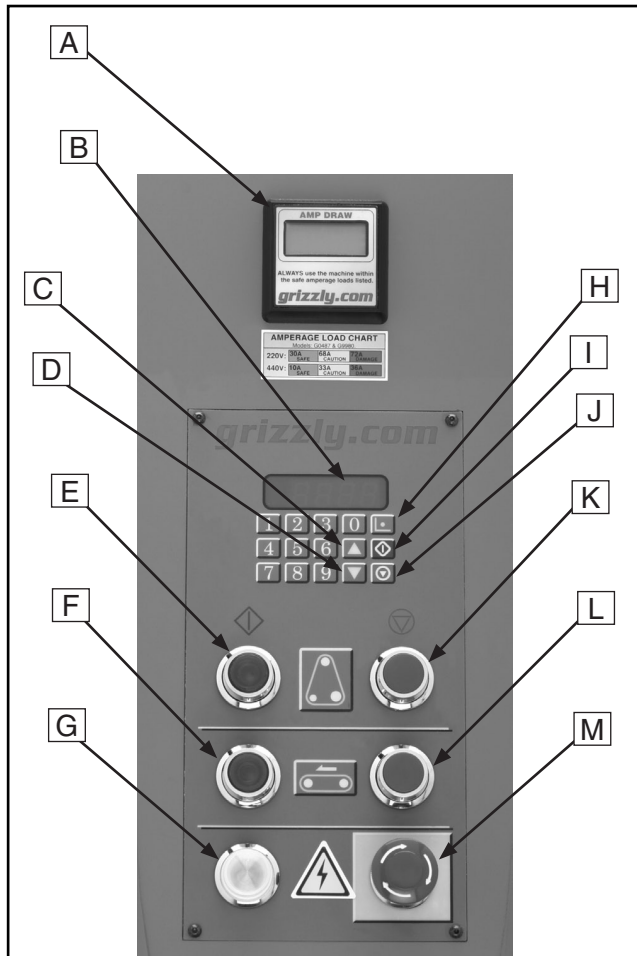

Figure 1. Control Panel, Model G0487.

- A. Digital Amp Draw Meter
- B. Table-Height Digital Readout
- C. Table Up Key
- D. Table Down Key
- E. Sanding Belt Start Button
- F. Conveyor Belt Start Button
- G. Power Light
- H. Table Set (Enter) Key
- I. Table Start Key
- J. Table Stop Key
- K. Sanding Belt Stop Button
- L. Feed Belt Stop Button
- M. Emergency Stop Button

# External Features

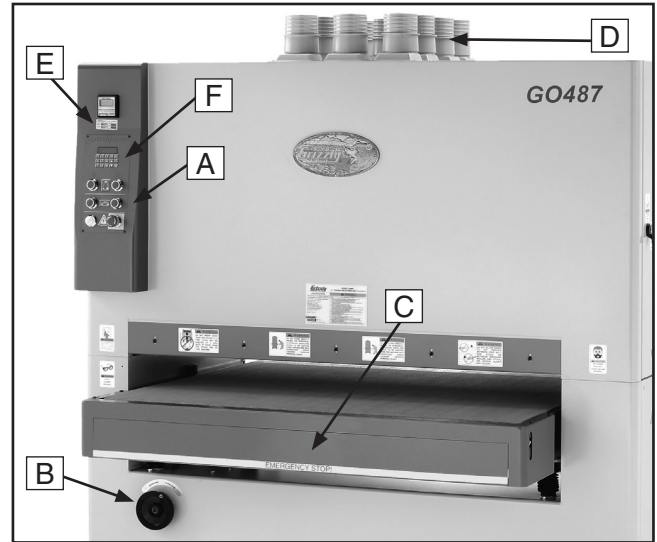

Figure 2. Front View, Model G0487.

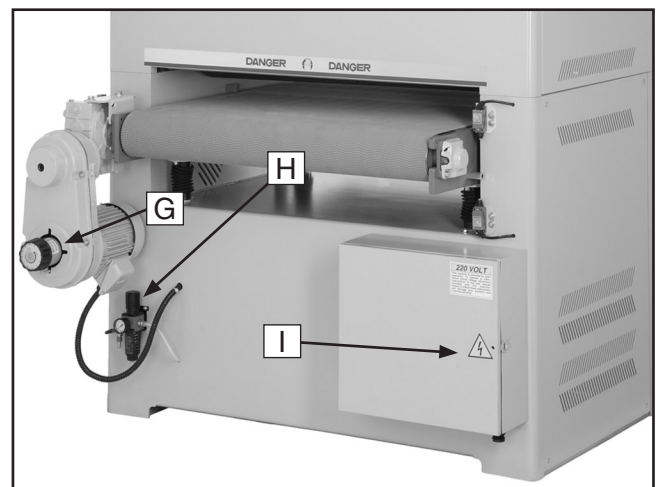
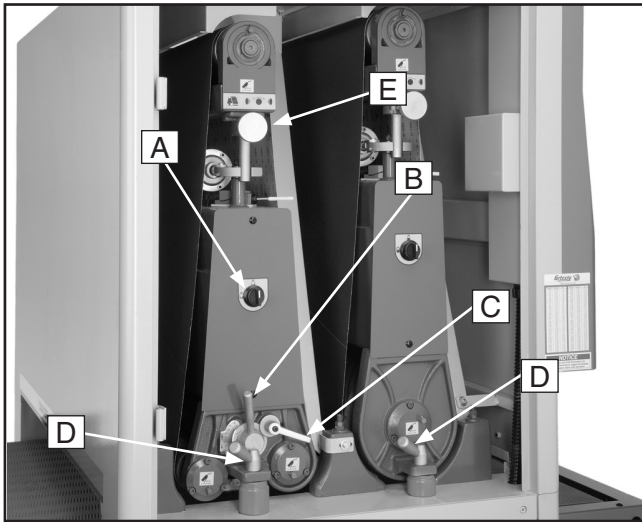

Figure 3. Rear View Model G0487.

- A. Control Panel
- B. Table Height Handwheel
- C. Emergency Stop Push-Panel
- D. 4" Dust Collection Ports
- E. Amperage Load Chart
- F. Digital Table Height Key Pad
- G. Conveyor Speed Control
- H. Air Pressure Regulator
- I. Main Wiring Box



# Internal Features



**Figure 4.** Inside the left access door.

- A.** Belt Tension Knob
- B.** Platen Adjustment Lever
- C.** Platen Adjustment Lock Lever
- D.** Lock Post Release Lever
- E.** Tracking Adjustment Knob

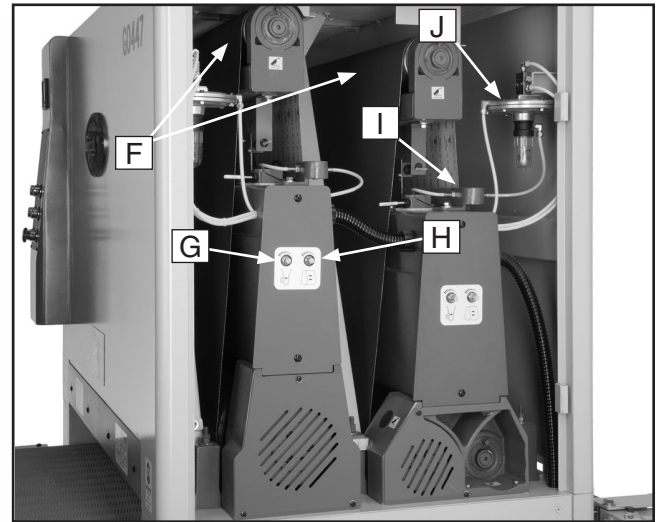

**Figure 5.** Inside the right access door.

- F.** Upper Rollers
- G.** Airflow Adjustment Knob
- H.** Speed Control Adjustment Knob
- I.** Air Fork and Air Jet
- J.** Diaphragm Valve Assembly





# MACHINE DATA SHEET

Customer Service #: (570) 546-9663 • To Order Call: (800) 523-4777 • Fax #: (800) 438-5901

## MODEL G0486 43" DOUBLE-HEAD TALL WIDE-BELT SANDER

Design Type ..... Floor Model

### Overall Dimensions:

Overall Height W/Dust Ports ..... 79"  
 Overall Height W/O Dust Ports ..... 73"  
 Overall Width ..... 63"  
 Overall Depth ..... 59½"  
 Conveyor Height at Lowest Setting ..... 32"  
 Net Weight ..... 3638 lbs.  
 Shipping Weight ..... 4079 lbs.  
 Footprint ..... 61" x 31"

### Capacities:

Maximum Board Width ..... 43"  
 Maximum Board Thickness ..... 6"  
 Minimum Board Length ..... 11"  
 Minimum Board Thickness ..... 3/16"  
 Drum Speed (Front) ..... 3543 FPM  
 Drum Speed (Rear) ..... 2565 FPM  
 Conveyor Speed ..... 14-60 FPM  
 Dust Ports ..... 10, 4"  
 Drum Diameter ..... (Front 7.87"), (Rear 4")

### Sanding Drum Motor:

Type ..... TEFC Induction  
 Horsepower ..... 25 HP  
 Voltage / Phase / Cycle ..... 220V / 440V Three-Phase / 60 HZ  
 Amps ..... 64 / 32A  
 RPM ..... 1725 RPM  
 Power Transfer to Drums ..... Twin and Triple V-Belt

### Conveyor Feed Motor:

Type ..... TEFC Induction  
 Horsepower ..... 2 HP  
 Voltage / Phase / Cycle ..... 220V / 440V Three-Phase / 60 HZ  
 Amps ..... 6 / 3A  
 RPM ..... 1725 RPM  
 Power Transfer ..... V-Belt

### Table Lift Motor:

Type ..... TEFC Induction  
 Horsepower ..... 1/4 HP  
 Voltage / Phase / Cycle ..... 220V / 440V Three-Phase / 60 HZ  
 Amps ..... 1.2 / 0.6A  
 RPM ..... 1725 RPM  
 Power Transfer ..... V-Belt

### General Construction:

Cabinet ..... Steel  
 Operating Air Pressure ..... 75 PSI  
 Sanding Belt Oscillation ..... Adjustable  
 Emergency Sanding Belt Brake ..... Air Disc Brake  
 Control Panel ..... Push Button Motor Controls, and Amp Load Meter  
 Sanding Belt ..... 43" x 75"  
 Graphite Size ..... 43" x 3.5"  
 Sanding Type ..... Platen Style

*Specifications, while deemed accurate, are not guaranteed.*





# MACHINE DATA SHEET

Customer Service #: (570) 546-9663 • To Order Call: (800) 523-4777 • Fax #: (800) 438-5901

## MODEL G0487 51" DOUBLE-HEAD TALL WIDE-BELT SANDER

Design Type ..... Floor Model

### Overall Dimensions:

Overall Height W/Dust Ports ..... 79"  
 Overall Height W/O Dust Ports ..... 73"  
 Overall Width ..... 71"  
 Overall Depth ..... 59½"  
 Conveyor Height at Lowest Setting ..... 32"  
 Net Weight ..... 4078 lbs.  
 Shipping Weight ..... 4740 lbs.  
 Footprint ..... 68" x 31"

### Capacities:

Maximum Board Width ..... 51"  
 Maximum Board Thickness ..... 6"  
 Minimum Board Length ..... 11"  
 Minimum Board Thickness ..... 3/16"  
 Drum Speed (Front) ..... 3543 FPM  
 Drum Speed (Rear) ..... 2565 FPM  
 Conveyor Speed ..... 14-60 FPM  
 Dust Ports ..... 10, 4"  
 Drum Diameter ..... (Front 7.87"), (Rear 4")

### Sanding Drum Motor:

Type ..... TEFC Induction  
 Horsepower ..... 30 HP  
 Voltage / Phase / Cycle ..... 220V / 440V Three-Phase / 60 HZ  
 Amps ..... 72 / 36A  
 RPM ..... 1725 RPM  
 Power Transfer to Drums ..... Triple and Twin V-Belt

### Conveyor Feed Motor:

Type ..... TEFC Induction  
 Horsepower ..... 2 HP  
 Voltage / Phase / Cycle ..... 220V / 440V Three-Phase / 60 HZ  
 Amps ..... 6 / 3A  
 RPM ..... 1725 RPM  
 Power Transfer ..... V-Belt

### Table Lift Motor:

Type ..... TEFC Induction  
 Horsepower ..... 1/4 HP  
 Voltage / Phase / Cycle ..... 220V / 440V Three-Phase / 60 HZ  
 Amps ..... 1.2 / 0.6A  
 RPM ..... 1725 RPM  
 Power Transfer ..... V-Belt

### General Construction:

Cabinet ..... Steel  
 Operating Air Pressure ..... 75 PSI  
 Sanding Belt Oscillation ..... Adjustable  
 Emergency Sanding Belt Brake ..... Air Disc Brake  
 Control Panel ..... Push Button Motor Controls, and Amp Load Meter  
 Sanding Belt ..... 51" x 75"  
 Graphite Size ..... 51" x 3.5"  
 Sanding Type ..... Platen Style

*Specifications, while deemed accurate, are not guaranteed.*



# SECTION 1: SAFETY

## WARNING

### For Your Own Safety, Read Instruction Manual Before Operating this Machine

The purpose of safety symbols is to attract your attention to possible hazardous conditions. This manual uses a series of symbols and signal words which are intended to convey the level of importance of the safety messages. The progression of symbols is described below. Remember that safety messages by themselves do not eliminate danger and are not a substitute for proper accident prevention measures.

 **DANGER** Indicates an imminently hazardous situation which, if not avoided, WILL result in death or serious injury.

 **WARNING** Indicates a potentially hazardous situation which, if not avoided, COULD result in death or serious injury.

 **CAUTION** Indicates a potentially hazardous situation which, if not avoided, MAY result in minor or moderate injury. It may also be used to alert against unsafe practices.

**NOTICE** This symbol is used to alert the user to useful information about proper operation of the machine.

## WARNING

### Safety Instructions for Machinery

- 1. READ THROUGH THE ENTIRE MANUAL BEFORE STARTING MACHINERY.** Machinery presents serious injury hazards to untrained users.
- 2. ALWAYS USE ANSI APPROVED SAFETY GLASSES WHEN OPERATING MACHINERY.** Everyday eyeglasses only have impact resistant lenses, they are NOT safety glasses.
- 3. ALWAYS WEAR A NIOSH APPROVED RESPIRATOR WHEN OPERATING MACHINERY THAT PRODUCES DUST.** Wood dust is a carcinogen and can cause cancer and severe respiratory illnesses.
- 4. ALWAYS USE HEARING PROTECTION WHEN OPERATING MACHINERY.** Machinery noise can cause permanent hearing damage.
- 5. WEAR PROPER APPAREL. DO NOT** wear loose clothing, gloves, neckties, rings, or jewelry which may get caught in moving parts. Wear protective hair covering to contain long hair and wear non-slip footwear.
- 6. NEVER OPERATE MACHINERY WHEN TIRED, OR UNDER THE INFLUENCE OF DRUGS OR ALCOHOL.** Be mentally alert at all times when running machinery.



# WARNING

## Safety Instructions for Machinery

7. **ONLY ALLOW TRAINED AND PROPERLY SUPERVISED PERSONNEL TO OPERATE MACHINERY.** Make sure operation instructions are safe and clearly understood.
8. **KEEP CHILDREN AND VISITORS AWAY.** Keep all children and visitors a safe distance from the work area.
9. **MAKE WORKSHOP CHILD PROOF.** Use padlocks, master switches, and remove start switch keys.
10. **NEVER LEAVE WHEN MACHINE IS RUNNING.** Turn power **OFF** and allow all moving parts to come to a complete stop before leaving machine unattended.
11. **DO NOT USE IN DANGEROUS ENVIRONMENTS.** DO NOT use machinery in damp, wet locations, or where any flammable or noxious fumes may exist.
12. **KEEP WORK AREA CLEAN AND WELL LIT.** Clutter and dark shadows may cause accidents.
13. **USE A GROUNDED EXTENSION CORD RATED FOR THE MACHINE AMPERAGE.** Undersized cords overheat and lose power. Replace extension cords if they become damaged. DO NOT use extension cords for 220V machinery.
14. **ALWAYS DISCONNECT FROM POWER SOURCE BEFORE SERVICING MACHINERY.** Make sure switch is in OFF position before reconnecting.
15. **MAINTAIN MACHINERY WITH CARE.** Keep blades sharp and clean for best and safest performance. Follow instructions for lubricating and changing accessories.
16. **MAKE SURE GUARDS ARE IN PLACE AND WORK CORRECTLY BEFORE USING MACHINERY.**
17. **REMOVE ADJUSTING KEYS AND WRENCHES.** Make a habit of checking for keys and adjusting wrenches before turning machinery **ON**.
18. **CHECK FOR DAMAGED PARTS BEFORE USING MACHINERY.** Check for binding and alignment of parts, broken parts, part mounting, loose bolts, and any other conditions that may affect machine operation. Repair or replace damaged parts.
19. **USE RECOMMENDED ACCESSORIES.** Refer to the instruction manual for recommended accessories. The use of improper accessories may cause risk of injury.
20. **DO NOT FORCE MACHINERY.** Work at the speed for which the machine or accessory was designed.
21. **SECURE WORKPIECE.** Use clamps or a vise to hold the workpiece when practical. A secured workpiece protects your hands and frees both hands to operate the machine.
22. **DO NOT OVERREACH.** Keep proper footing and balance at all times.
23. **MANY MACHINES WILL EJECT THE WORKPIECE TOWARD THE OPERATOR.** Know and avoid conditions that cause the workpiece to "kickback."
24. **ALWAYS LOCK MOBILE BASES (IF USED) BEFORE OPERATING MACHINERY.**
25. **BE AWARE THAT CERTAIN WOODS MAY CAUSE AN ALLERGIC REACTION** in people and animals, especially when exposed to fine dust. Make sure you know what type of wood dust you will be exposed to and always wear an approved respirator.



## **WARNING**

# Additional Safety for Wide Belt Sanders

- 1. INFEEED/OUTFEED AREA.** When feeding the workpiece into the machine, keep clear of kickback path.
- 2. WORKPIECE FEEDING.** Never force the workpiece into the sander, and feed only one workpiece at a time.
- 3. CLOTHING.** Roll up or button sleeves, tie all loose clothing or hair so it will keep clear of entanglement hazards.
- 4. NARROW WORKPIECES.** Never sand workpieces narrower than  $\frac{3}{16}$ ".
- 5. THIN WORKPIECES.** Never sand workpieces thinner than  $\frac{3}{16}$ ".
- 6. SHORT WORKPIECES.** Never sand workpieces shorter than 11".
- 7. HANDS.** Never place hands near, or in contact with, sanding drums or conveyor belt during operation.
- 8. MAINTENANCE.** Perform machine inspections and maintenance service at the appropriate time intervals.
- 9. POWER AND AIR DISCONNECT.** Unless specifically stated in the manual, always disconnect the power source and air from the machine when performing maintenance, adjustments, or assembly. Always read and follow specific safety instructions for each section.
- 10. UNATTENDED MACHINE.** Never leave the machine running unattended.
- 11. SANDPAPER.** Replace sanding belt when it becomes worn or damaged.
- 12. FOREIGN MATERIAL.** Always inspect workpiece for nails, staples, knots, and other imperfections that could be dislodged and thrown from the machine during sanding operations.
- 13. DUST COLLECTION.** Never operate the sander without an adequate dust collection system in place and running.
- 14. ALLERGIES.** Certain woods may cause an allergic reaction in people and animals, especially when exposed to fine dust. Make sure you know what type of wood dust you will be exposed to and always wear an approved respirator.
- 15. ACCESS DOORS.** Never perform sanding operations when the side access doors are open.
- 16. UNDERSTAND INSTRUCTIONS.** Never allow unsupervised or untrained personnel to operate the machine. Make sure any instructions you give in regards to machine operation are approved, correct, safe, and clearly understood.

## **WARNING**

Unfamiliarity with this manual could result in serious personal injury. Spend a sufficient amount of time becoming familiar with the contents of this manual, including all the safety warnings.

## **WARNING**

No list of safety guidelines can be complete. Operating this machinery may require additional safety precautions specific to your shop environment. Failure to use reasonable caution while operating this machine could result in serious personal injury.



# SECTION 2: CIRCUIT REQUIREMENTS

## 220V/440V Connection

Hard wire this machine to a power panel that has proper overload protection and a locking shut-off lever (**Figure 6**). If you are unsure about electrical wiring, consult a qualified electrician before attempting any wiring.

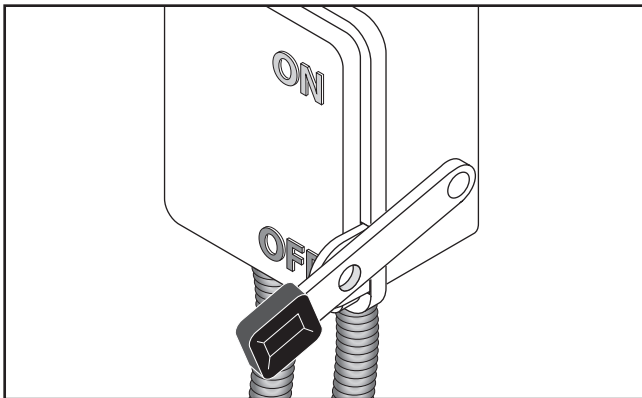

**Figure 6.** Locking Shut-Off Lever.

## Grounding

	<p><b>⚠ WARNING</b></p> <p>Electrocution or fire may result if machinery is incorrectly grounded or the power supply violates local and state codes. Contact a qualified electrician for safe wiring practices!</p>
--	---

## Amperage Loads

The following list outlines the electrical phase and voltage required to operate the Model G0486/G0487, as well as the amperage draw of their motors and circuit requirements.

**Note:** *If you do not have three-phase power available, you will have to install a phase converter such as the Grizzly Phase Converter.*

### Amperage Draw Specifications:

<b>G0486—220V, Three-Phase ~90 Amp Circuit</b>	
25 HP Sanding Motor.....	64 Amps
2 HP Feed Motor.....	6 Amps
¼ HP Table Motor.....	1.2 Amps
<b>G0486—440V, Three-Phase ~50 Amp Circuit</b>	
25 HP Sanding Motor.....	32 Amps
2 HP Feed Motor.....	3 Amps
¼ HP Table Motor.....	0.6 Amp
<b>G0487—220V, Three-Phase ~100 Amp Circuit</b>	
30 HP Sanding Motor.....	72 Amps
2 HP Feed Motor.....	6 Amps
¼ HP Table Motor.....	1.2 Amps
<b>G0487—440V, Three-Phase ~50 Amp Circuit</b>	
30 HP Sanding Motor.....	36 Amps
2 HP Feed Motor.....	3 Amps
¼ HP Table Motor.....	0.6 Amp

## Extension Cords

Do not use an extension cord with 220V/440V machinery. An extension cord increases the risk of electrocution and fire. Instead, position your equipment near the power supply to eliminate the extension cord requirement.



# 440V Connection

To connect this machine to 440V three-phase power, you must purchase two thermal overload relays. Each machine model requires unique relays, so refer to **440 Conversion Kits** on **Page 65** or the relay part numbers.

If you do not have three-phase power available for your wide belt sander, you must install a phase converter. We recommend using Grizzly Phase Converter Model H3741 for Model G0486 and Model H3742 for Model G0487.

**Note:** When using a phase converter, the power from the manufactured power leg (sometimes called the wild wire) can fluctuate. Connect the manufactured power leg to the S terminal to prevent damage to the transformer. The wire from the S terminal can handle some fluctuation because it goes directly to the motor. The power going to the R and T terminals goes to the transformer and must be consistent to prevent damage.

## To wire the sander to 440V:

1. DISCONNECT THE SANDER FROM THE POWER SOURCE!
2. Open the electrical box located on the back of the machine.
3. On the transformer, remove the wire labeled "1" connected to the 220V terminal, and connect it to the 440V terminal as shown in **Figure 7**.

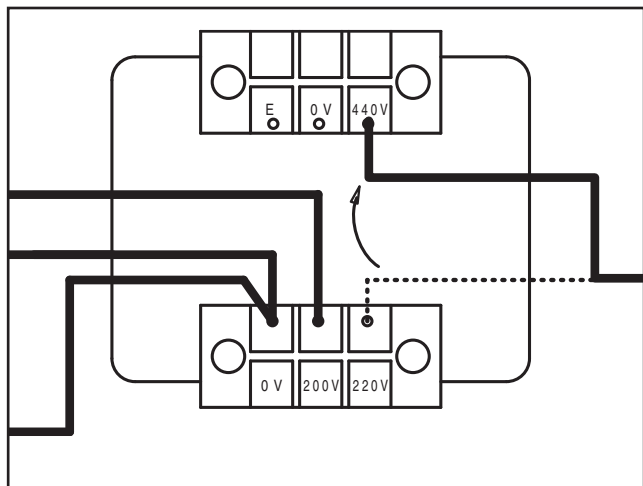
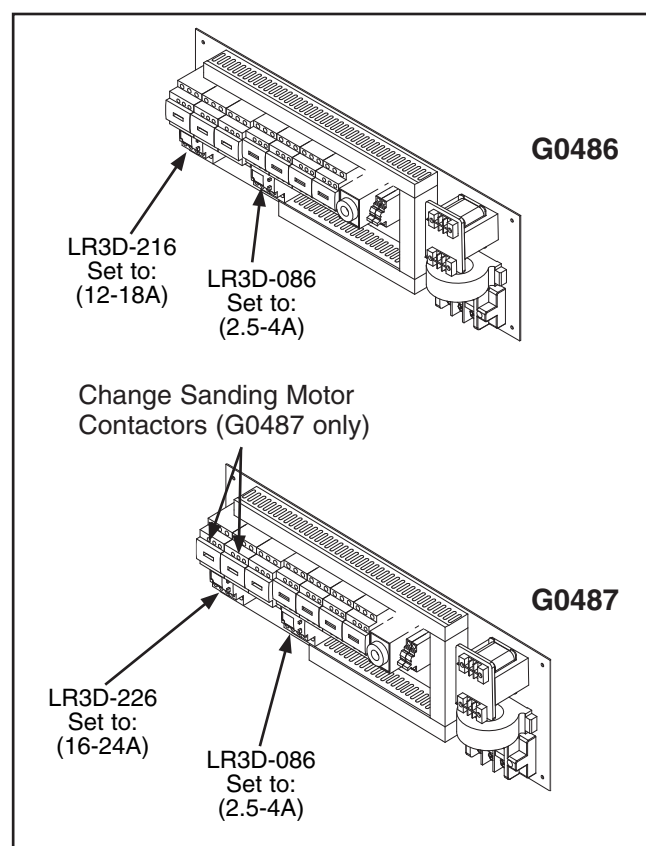

**Figure 7.** 440V connections, Model G0486/G0487.

4. Refer to **Figure 8** and find the power panel on your machine.
5. Swap out the applicable thermal relays and contactors from the conversion kit at the locations shown in **Figure 8**, and set them to the overload values listed.

—For the G0486, use conversion kit #P04868139 and change out two relays.

—For the G0487, use conversion kit #P04878139. Change out two relays and change the two LC1-D40 sanding motor contactors with two LC1-D386 contactors.



**Figure 8.** Thermal overload relays.

6. Wire the sanding belt, conveyor belt, and table elevation motors as shown on the diagrams on the inside of each motor wire cover, or refer to **Motor Wiring** on **Page 47**.



# SECTION 3: SET UP

## Unpacking

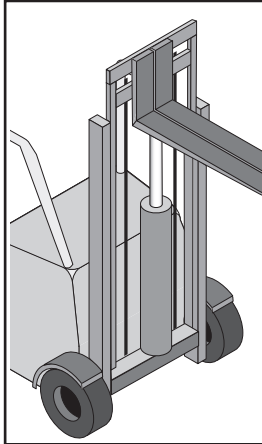

### **!WARNING**

**This sander is a heavy machine weighing over 4000 lbs (shipping weight). Personal injury can occur if the machine is moved without appropriate machinery. Use a crane or forklift when moving or lifting the machine.**

Your wide belt sander was carefully packed when it left our warehouse. If you discover the machine is damaged after you have signed for delivery, please immediately call Customer Service at (570) 546-9663 for advice.

Save the containers and all packing materials for possible inspection by the carrier or its agent. Otherwise, filing a freight claim can be difficult.

When you are completely satisfied with the condition of your shipment, you should inventory the contents.

## Items Needed for Set Up

The following items are needed to complete the set up process, but are not included with your machine:

Description	Qty
• Safety Glasses (for each person) .....	1
• Solvent Cleaner .....	As Needed
• Dust Collection System .....	1
• 4" Dust Hoses (length as needed) .....	10
• 4" Hose Clamps .....	10
• Air Compressor (12 CFM @75 PSI) .....	1

G0486/G0487 Wide Belt Sander



## Inventory

Crate contents, (Figure 9). Qty

A. Sanding Unit (Not Pictured) .....	1
B. Dust Ports 4" (G0486, G0487) .....	10
C. Sanding Belt 100 Grit .....	1
D. Sanding Belt 180 Grit .....	1
E. Platen Felt* .....	1
F. Platen Graphite Flap* .....	1
G. Tool Box .....	1
• Phillips Head Screwdriver #2 .....	1
• Standard Screwdriver #2 .....	1
• Open-End Wrench 8/10mm .....	1
• Open-End Wrench 12/14mm .....	1
• Open-End Wrench 17/19mm .....	1
• Metric Hex Wrench Set 10 Pcs. ....	1
• Door Keys .....	2
• Ceramic Limit Switch Posts* .....	2
• Platen Removal Tool .....	1
• Flexible Grease Gun Extension* .....	1

\*Spare parts not needed for set up

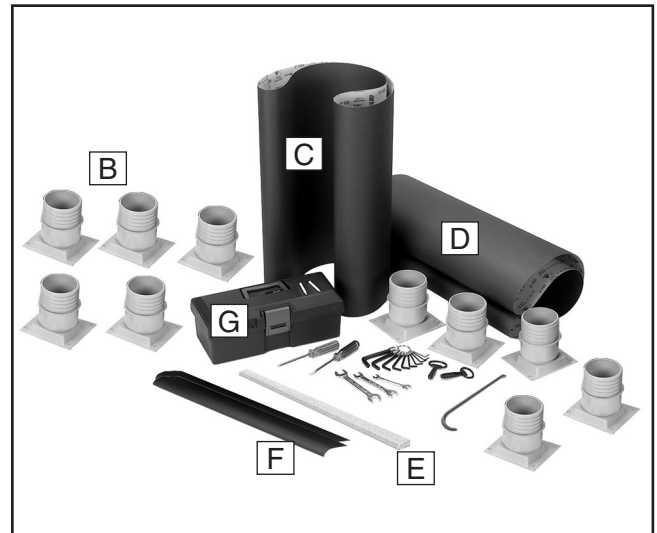

Figure 9. Parts layout.

### **NOTICE**

**A parts diagram and parts list are located near the end of the manual. Use the diagram and list to identify missing parts or to supplement the assembly instructions provided in this manual.**

# Hardware Chart

USE THIS CHART TO MATCH UP HARDWARE DURING THE ASSEMBLY PROCESS!

MEASURE BOLT DIAMETER BY PLACING INSIDE CIRCLE

- #10
- 1/4"
- 5/16"
- 3/8"
- 7/16"
- 1/2"

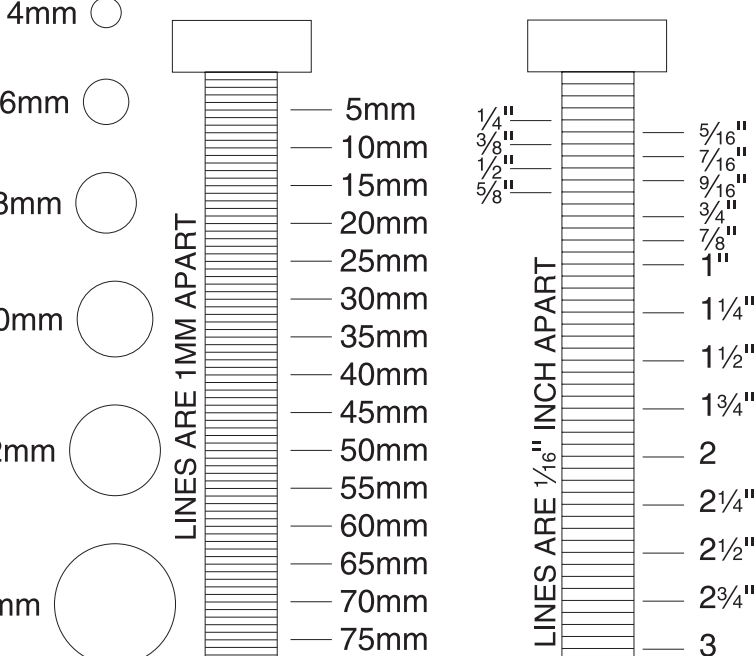
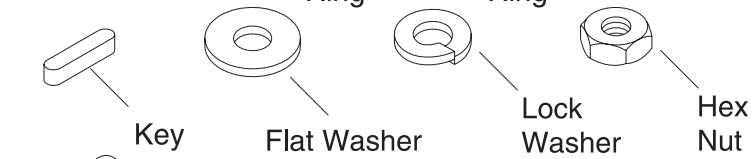
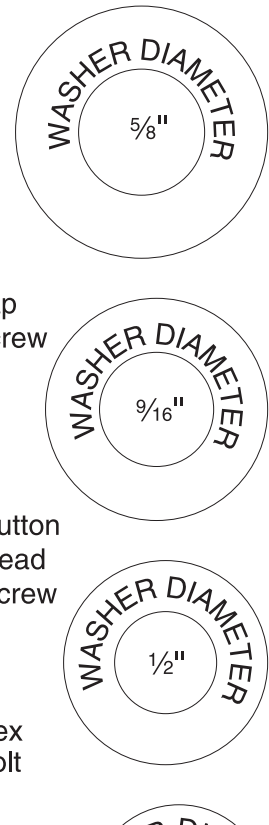
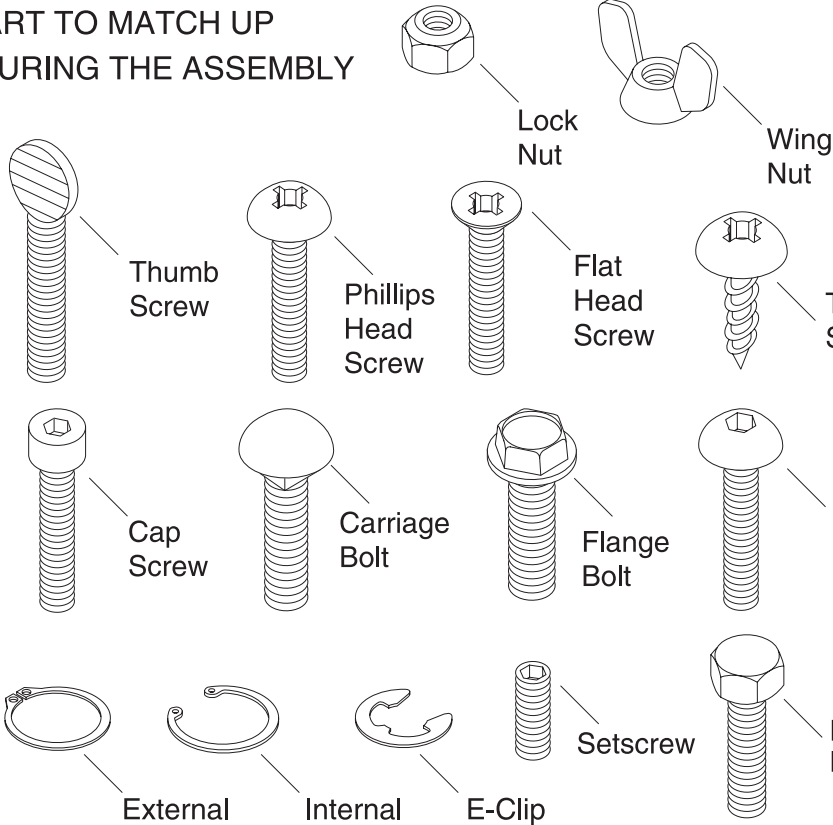

WASHERS ARE MEASURED BY THE INSIDE DIAMETER

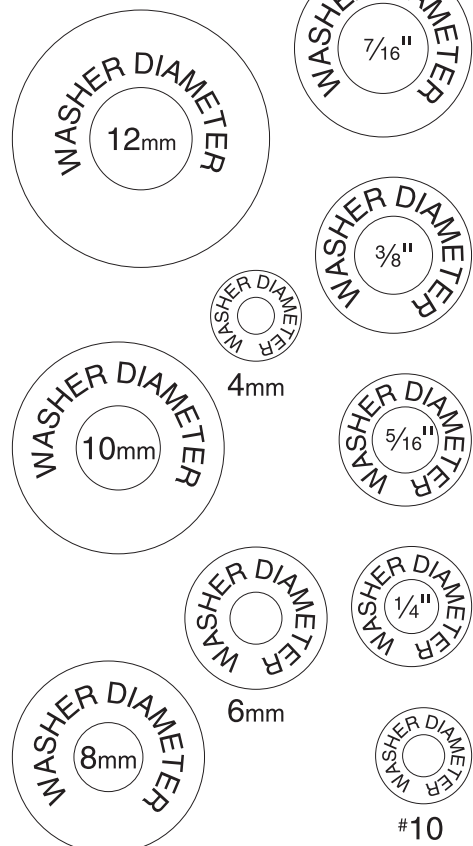

# Clean Up

Any unpainted surfaces are coated with a waxy oil to protect them from corrosion during shipment. Remove this protective coating with a solvent cleaner or citrus-based degreaser such as Grizzly's G7895 Degreaser. To clean thoroughly, some parts may need to be removed. **For optimum performance from your machine, make sure you clean all moving parts or sliding contact surfaces that are coated.** Avoid chlorine-based solvents as they will damage painted surfaces should they come in contact.

## NOTICE

The steel sanding belt rollers have been coated with an export grease to protect them from rust. This grease should be removed before installing the sanding belt.



## WARNING

Gasoline and petroleum products have low flash points and could explode if used to clean machinery. **DO NOT** use gasoline or petroleum products to clean the machinery.

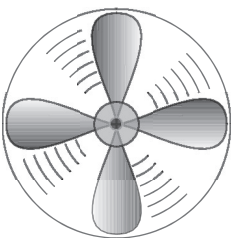

## WARNING

Lack of ventilation while using solvents could cause serious personal health risks, fire, or environmental hazards. Always work in a well ventilated area to prevent the accumulation of dangerous fumes. Supply the work area with a constant source of fresh air.

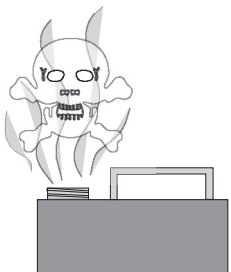

# Site Considerations

## Floor Load

Refer to the **Machine Data Sheet** for the weight and footprint specifications of your machine. Some residential floors may require additional reinforcement to support both the machine and operator.

## Working Clearance

Consider existing and anticipated needs, size of material to be processed through each machine, and space for auxiliary stands, work tables or other machinery when establishing a location for your new machine. See **Figure 10** for the minimum working clearances.

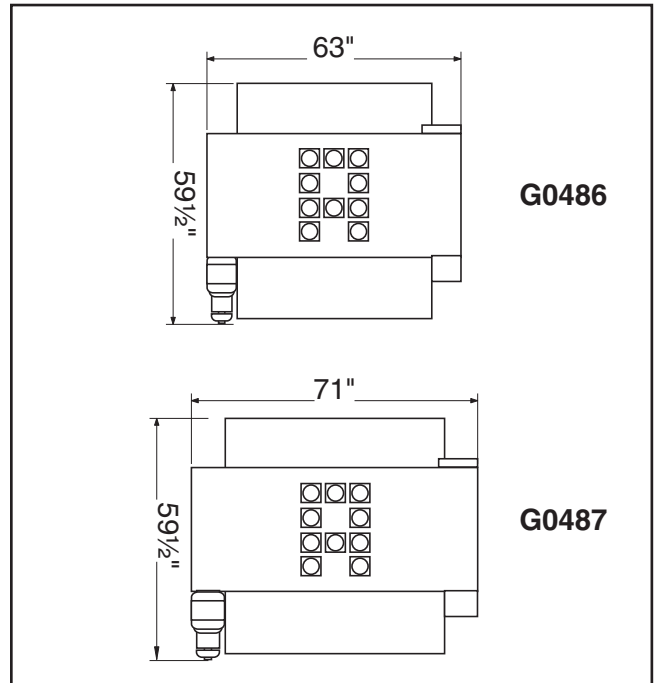
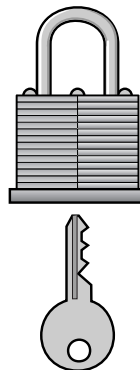

Figure 10. Minimum working clearances.



## WARNING

Unsupervised children and visitors entering a shop could suffer serious personal injury. Ensure child and visitor safety by keeping all entrances to the shop locked at all times. **DO NOT** allow unsupervised children or visitors in the shop at any time.



# Beginning Assembly

Complete the assembly in the order provided in this manual. Then read the rest of the manual before attempting any type of sanding operation. **Your safety is important! Please follow the warnings below during this entire section:**

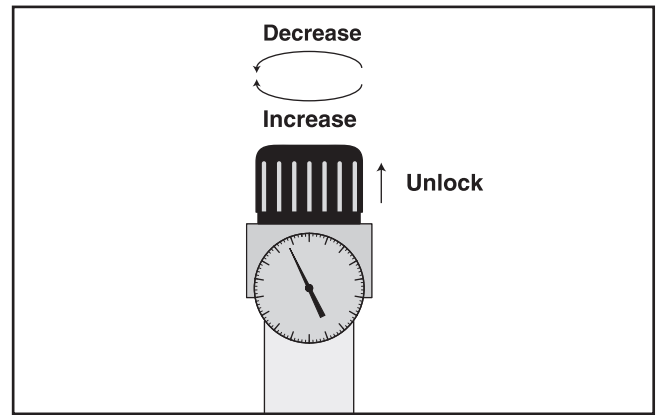
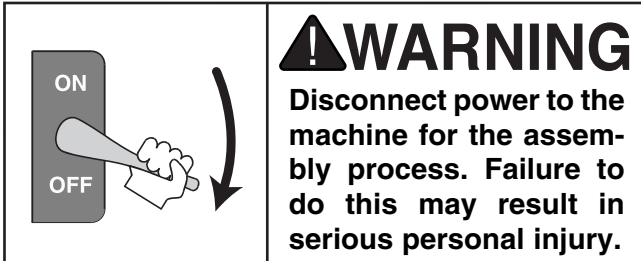

Figure 12. Regulator knob.

## Air Line Installation

To install the air line:

1. Connect the hose from your air compressor to the air inlet (**Figure 11**) on the regulator.

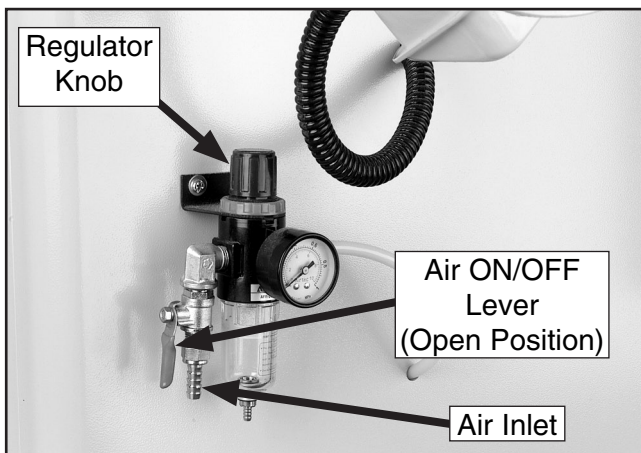

Figure 11. Air inlet located on regulator.

2. Make sure the red handle on the regulator is in the open position (parallel with the air inlet).
3. Lift the regulator knob (**Figures 11 & 12**) and turn it until the air pressure gauge reads 75 PSI. **Note:** Turn the knob clockwise to increase the air pressure and counterclockwise to lower the air pressure.
4. Push the regulator knob down until it snaps.

## Dust Collection

An efficient and clean dust collection system is essential to the proper function of the sander. Ensuring a healthy work environment is also dependent upon cleaning and maintaining your dust collection system. 4000 CFM is recommended at the dust ports.

To hook up a dust collection system:

1. Install all ten dust ports (**Figure 13**) to the mounting locations on the top of the sanding unit with the supplied M6-1 x 10 Phillips head screws.



Figure 13. A typical screw configuration.

2. Using 4" hose clamps, secure the hoses from your dust collection system to the dust ports.



# Sanding Belt

## To install the sanding belt:

1. DISCONNECT THE SANDER FROM THE POWER SOURCE AND REMOVE AIR PRESSURE COMPLETELY!
2. De-activate the belt tension piston by turning the belt tension knob (**Figure 14**).
3. Remove the lock post release lever (**Figure 14**) by turning it counterclockwise  $\frac{1}{2}$  turn and pulling it up and out of the mounting hole.
4. Remove the spacer block (**Figure 14**).

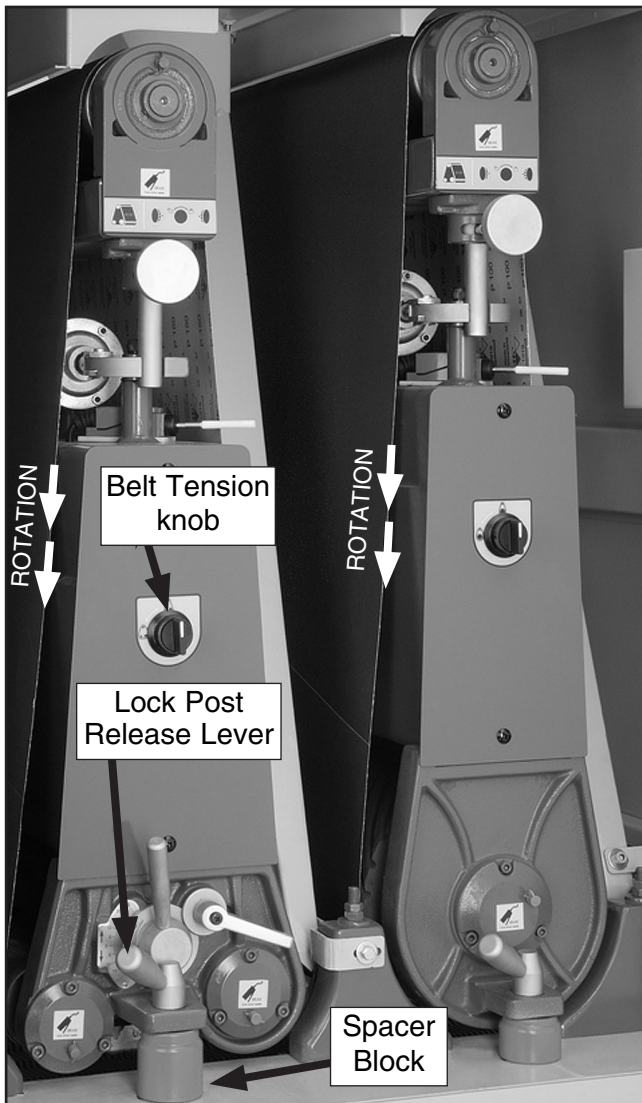

**Figure 14.** Components used when changing a sanding belt.

5. Ensuring the rotation arrows on the sanding belt point the same direction as those shown in **Figure 14**, install the sanding belt by starting first on the upper roller, and then the lower roller.

**Note:** The sanding belt must be centered between the limit switches and the edge of the sanding belt must be between tongs of the oscillation controller as shown in **Figure 15**. Damage to the sanding belt could occur if the sander is turned **ON** before the sanding belt is correctly positioned.

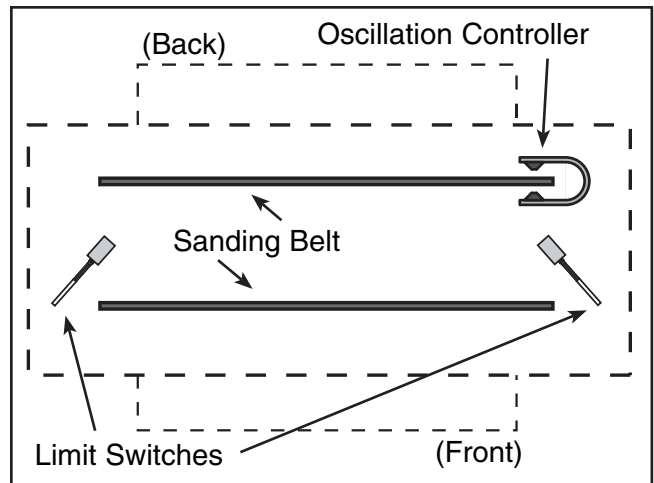

**Figure 15.** Sander Outline (Top View). Proper position of belt between the limit switches.

## **NOTICE**

The directional arrow on the back of the sanding belt must be pointing in a counterclockwise direction during installation. Failure to install the sanding belt correctly could result in damage to the sanding belt or the sander itself.

6. Replace the spacer block and tighten down the lock handle bolt.
7. With your hands clear of all moving parts, tension the belt by turning the belt tension knob.



# Pressure Rollers

The pressure rollers have been set at the factory, but for safety, you should verify that they are set below the level of the sanding roller.

## **⚠️WARNING**

It is absolutely essential to keep the pressure rollers set below the level of the sanding roller. If the pressure rollers are even, or higher than the sanding roller, the wood **WILL** be propelled from the sander at a high rate of speed. This situation could cause serious kick-back injury.

To check the pressure roller height:

1. DISCONNECT THE SANDER FROM THE POWER SOURCE!
2. Place a piece of scrap wood of uniform thickness across the table so it spans both the front and the rear pressure rollers at the same time.
3. With the air pressure connected and the sanding belt installed and tensioned, manually raise the table and verify that the board touches both pressure rollers before it touches the sanding belt.

**Note:** *If the board does not touch both pressure rollers before it touches the sanding belt, then the pressure rollers MUST be adjusted before operation. See "Pressure Rollers" on Page 32 for step-by-step instructions.*

# Start Up

## **⚠️WARNING**

Serious personal injury could result if the machine is connected to the power source during assembly or adjustment. Wait until the machine is turned off, unplugged, and all working parts have come to a complete stop before you attempt to assemble or adjust the machine!

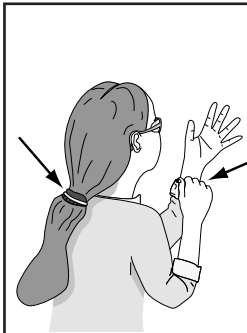

## **⚠️WARNING**

Loose hair and clothing could get caught in machinery causing serious personal injury. Keep loose clothing rolled up and long hair tied up and away from machinery.



## **⚠️WARNING**

Projectiles thrown from the machine could cause serious eye injury. Wear safety glasses during start up.

Before starting the machine:

1. Read this manual and make sure you take all safety precautions before operating this machine.
2. Make sure the machine is connected to an air compressor and the pressure gauge reads 75 PSI.
3. Make sure all tools or foreign objects have been removed from the conveyor surface, the top of the machine, and the inside of the machine.
4. Make sure all the wiring is correct.



## To start the machine:

1. **Wear safety glasses, hearing protection, and a respirator at all times when running the machine!**
2. Connect the machine to the power source.
3. Press the TABLE UP and TABLE DOWN keys. The table should move up and down smoothly.

**Note:** *Make sure the table moves in the same direction as the button description. If not, then the power needs to be disconnected and any two power wires need to be switched at the circuit breaker in the electrical box. If using a phase converter, switch the R and T wires.*

4. Press the FEED BELT START and FEED BELT STOP buttons. The feed belt should start, run, and stop smoothly.
5. Press the SANDING BELT START and SANDING BELT STOP buttons. The sanding belt should start, run, and stop smoothly.

The machine should run smoothly, with little or no vibration or rubbing noises. Strange or unnatural noises should be investigated and corrected before operating the machine further.

If the machine seems to be running correctly, let it run for a short time to ensure that the moving parts are working properly with no excessive vibration. DO NOT operate the machine if problems cannot be corrected.

If you cannot locate the source of unusual noises, refer to **Troubleshooting**, then feel free to contact our Technical Support Department at (570) 546-9663.

# Recommended Adjustments

---

---

For your convenience, the adjustments listed below have been performed at the factory and require no further adjustment. However, we recommend that you verify that the adjustments are correct and to your satisfaction.

## Recommended adjustment checklist:

- Table Calibration, Page 27.
- Feed Belt Tension, Page 36.
- Feed Belt Tracking, Page 36.
- Air Regulator to 75 PSI, Page 26.
- Oscillation Timing, Page 29.
- Oscillation Speed, Page 31.
- Pressure Rollers, Page 32.
- Table Parallelism, Page 31.
- V-Belt Adjustment, Page 33.



# SECTION 4: OPERATIONS

## Operation Safety

Your safety is important! Please follow the warnings below during this entire section:

### **WARNING**

To avoid serious personal injury, read and become familiar with the entire instruction manual before using this wide belt sander.

### **WARNING**

Damage to your eyes, lungs, and ears could result from failure to wear safety glasses, a dust mask, and hearing protection while sanding with this machine.

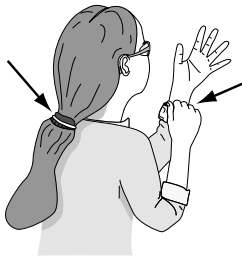

### **WARNING**

Loose hair and clothing could get caught in machinery and cause serious personal injury. Keep loose clothing rolled up and long hair tied up and away from machinery.

## Choosing Sandpaper

The grit you choose will depend on the type of work, the species of wood and the stage of finishing. Below is a chart that groups abrasives into different categories and shows which grits fall into each one. We recommend using aluminum oxide sanding belts for the best results.

Grit	Type
60	Coarse
80-100	Medium
120-150	Fine

The general rule of thumb is to sand a workpiece with progressively higher grit numbers, with no one grit increase of more than 50.



# Table Movement

The table height can be adjusted manually or with the digital key pad and motor (see **Figure 16**).

**Manual Table Movement:** Turn the handwheel located under the front of the infeed table for manual table positioning.

**Motorized Table Movement:** Press the TABLE UP or TABLE DOWN key once for motorized table positioning in 0.005" (0.125mm) increments.

**Numerical Key Pad:** Enters the position of sanding depth (See **Page 23**).

**Metric or Standard Key:** Press and hold the SET button for 3 seconds to calibrate display at the current board thickness (**Page 27**); or press and hold key for 10 seconds to toggle the display between metric and standard measurement.

**Table Start Key:** Moves table to a preset sanding depth.

**Table Stop Key:** Stops table movement immediately.

**Digital Display:** Shows final table sanding depth.

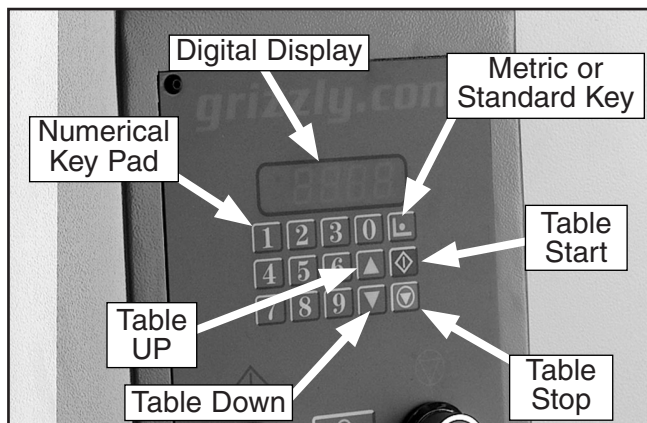

**Figure 16.** Keys for adjusting the table height.

## **NOTICE**

**The thickness gauge is pre-calibrated from the factory; however, correct calibration should be verified.**

# Adjusting Feed Rate

The dial attached to the side of the feed belt gear box (**Figure 17**) adjusts the feed rate of the sander.

**Note:** *Never adjust the feed rate dial unless the conveyor belt is running, otherwise you can damage the control.*

**Changing Feed Rate:** Turn the dial clockwise to decrease the feed rate and counterclockwise to increase it.

**Determining Ideal Feed Rates:** Softwoods typically require a faster feed rate than hardwoods; however, there is no definitive rule to follow when determining the best feed rate. As a general rule, always start with the slowest feed rate and work your way up. We always recommend testing the feed rate using scrap wood similar to your workpiece. Be sure to monitor the amperage meter when adjusting the feed rate. Decrease the feed rate if the load begins to slow the motor RPM to damaging levels.

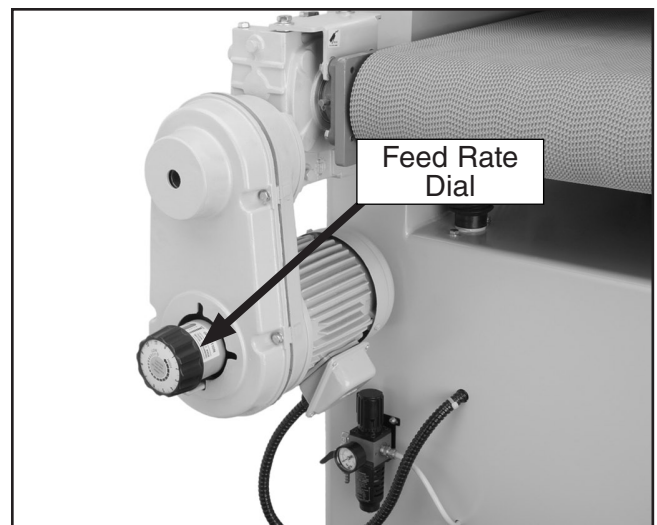

**Figure 17.** Feed rate dial.



# Amp Draw Meter

The amperage draw meter (**Figure 18**) is located above the control panel. Use the meter to monitor the amperage draw on the machine while performing sanding operations.

As a general rule, always start with a small load and work your way up. **DO NOT** work your machine to its maximum load, where you can hear the motor lose RPM; instead, make multiple passes or install a coarser grit paper.

Amp load will be directly affected by many factors such as feed rate, depth of cut, wood type, sandpaper grit, and workpiece width. If the amp load is in the red load range, the machine is overloaded and motor damage will occur. Keep the amp load in the green range during operation.

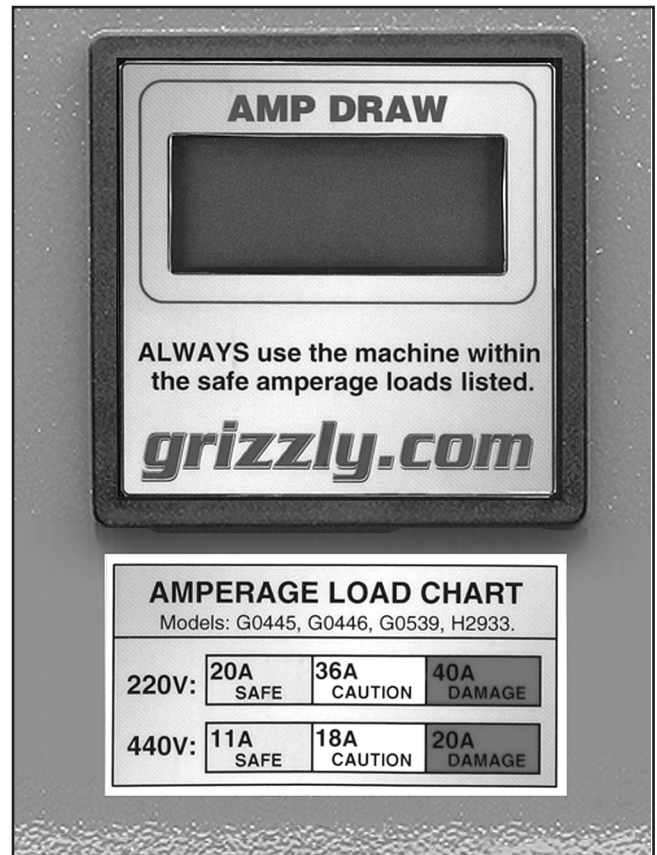

**Figure 18.** Typical amp draw meter and load chart.

## **NOTICE**

**DO NOT VOID WARRANTY!** Keep the amp draw within the **GREEN** load range shown on the **AMP LOAD CHART**. If you operate the sander in the **RED** load range, capacitor or motor failure will occur and will not be covered under warranty.



# Sanding Workpiece

Typically, no more than 0.5mm (approx.  $\frac{1}{64}$ " ) of material is removed during each pass. Attempts to remove too much material can cause jamming, wood burning, rapid sandpaper wear or tearing, poor finish, short motor life, and belt slippage.

The following is the correct sanding operating procedure:

1. Put on safety glasses, a dust mask, and your hearing protection!
2. Turn **ON** the dust collector.
3. On the initial pass, lower the table to approximately 0.25" greater than the thickness of the workpiece.

**Note:** This initial pass setting reduces the chance of overloading the sander on undetected high points on the workpiece.

4. Raise the table 0.0625" between each successive pass until the sander begins to sand the workpiece.

## NOTICE

It may be necessary to send wide stock through the sander two or three times between table height adjustments. This reduces the likelihood of burning the wood if there is a high spot.

# Platen Adjustment

Your sander is equipped with an adjustable felt platen and graphite slip for those extra sensitive sanding operations. The platen position allows for 3 basic types of sanding. These different positions can be adjusted by rotating the height lever shown in **Figure 19**.

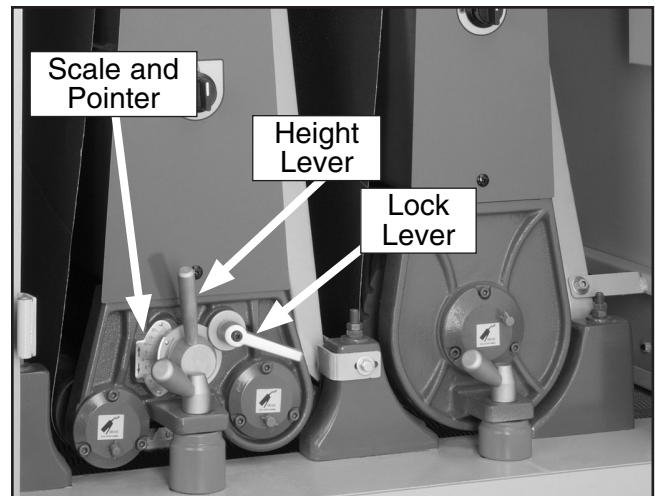

**Figure 19.** Platen height controls.

## The three basic platen positions:

**Platen Up:** The platen is raised above the level of the sanding rollers. This position allows the front roller to remove large amounts of material quickly, but leaves a rough finish. The best belt grit for this position is #100 or coarser.

**Platen Even:** The platen is set even with the sanding rollers. The rollers work together with the platen to produce intermediate/final finishing. The best belt grit for this position is #100-#180.

**Platen Down:** The platen is lowered below the sanding rollers. The majority of the work is accomplished by the platen pressure on the workpiece. The result is a smooth, flat finish. The best belt grit for this position is #180 or finer. Avoid lowering the platen more than 0.2 mm below the sanding belt rollers, or you will prematurely wear the platen.



# SECTION 5: ACCESSORIES

## H3741—30 HP Rotary Phase Converter

## H3742—40 HP Rotary Phase Converter

Add 3-phase, multi-motor capability to your single-phase electrical supply. Operate single or multiple motors, transformers, and resistance loads at 100% power and 95% efficiency while saving big dollars at cheaply metered, singlephase electrical rates. Complete step by step instructions are furnished along with complete wire and fusing requirements for various motor loads. Each model operates up to twice its nameplate rating in a mixed-motor load. On heavily loaded or hard-start applications, such as highspeed geared-head lathes and air conditioning compressors, the nameplate rating of the converter you choose should be 2 to 3 times the HP of the most heavily loaded motor. See the individual 3-phase machine pages for phase converter recommendations. For application assistance, please call our technical support at (570) 546-9663.

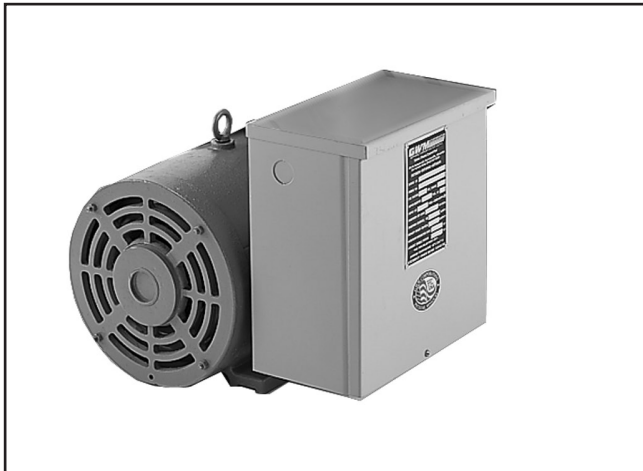

Figure 20. Rotary phase converter.

## H2845—Cleaning Pads

Cleaning pads are the perfect accessory for wide belt sanders. Simply set the conveyor table to height and feed the pad through to “unload” a dirty sanding belt. Regular cleaning greatly increases the lifespan of sanding belts. Check with the current Grizzly catalog or [www.grizzly.com](http://www.grizzly.com) for more details.

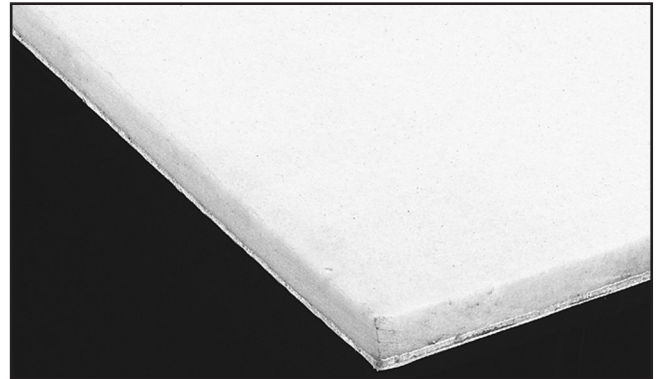

Figure 21. Sanding belt cleaning pad.

## US-Made Sanding Belts for Model G0486 43”W x 75”L:

### Single Pack

- H9117 60 Grit
- H9118 80 Grit
- H9119 100 Grit
- H9120 120 Grit
- H9121 150 Grit

### 3-Pack

- H9122 60 Grit
- H9123 80 Grit
- H9124 100 Grit
- H9125 120 Grit
- H9126 150 Grit
- H9127 Assorted Grits

## US-Made Sanding Belts for Model G0487 51”W x 75”L:

### Single Pack

- H9106 60 Grit
- H9107 80 Grit
- H9108 100 Grit
- H9109 120 Grit
- H9110 150 Grit

### 3-Pack

- H9111 60 Grit
- H9112 80 Grit
- H9113 100 Grit
- H9114 120 Grit
- H9115 150 Grit
- H9116 Assorted Grits

Call 1-800-523-4777 To Order

G0486/G0487 Wide Belt Sander



# SECTION 6: MAINTENANCE

## General

Your safety is important! Please follow the warnings below during this entire section:

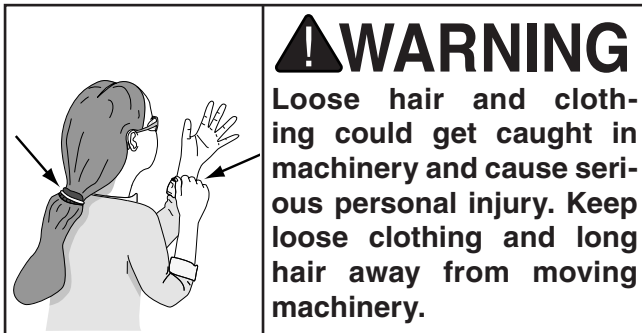
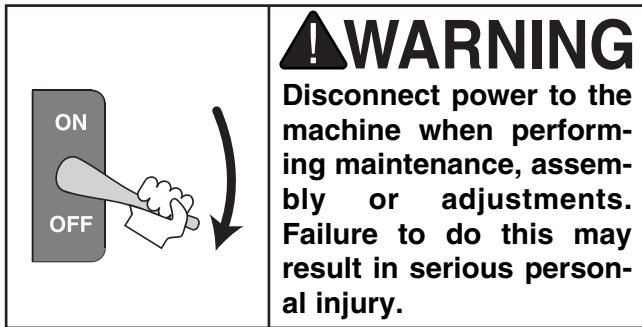

## Schedule

The following items should be checked each time the sander is used:

- Loose mounting bolts.
- Damaged sanding belt.
- Worn or damaged wires.
- Water collection cups filled with water.
- Dust trap.
- Safety features.
- Any other condition that could hamper the safe operation of this machine.

### Weekly

Grease the grease fittings located on the feed belt roller axles and the sanding belt roller axles with Gear Lube-2 (GL-2) or automotive grease. They are identified with yellow labels.

### Monthly

Apply a generous amount of GL-2 grease to the table elevation screws. Be sure to recover the adjustment screws with the dust covers when finished.

Remove the lower side panel to access the table lifting mechanism. Apply GL-2 grease to the chain and gears associated with the table lifting mechanism. Be careful to not get grease on the V-belts. This could cause them to slip off of the pulleys.

### Yearly

Replace the internal white moisture filters.

### After the First 100 Hours

The oil inside the conveyor gear reducer should be replaced after the first 100 working hours of operation. We recommend 90 Wt. gear oil.

### Every 2500 Hours

After the first conveyor gear reducer oil change, replace the oil after every 2500 working hours of operation. We recommend 90 Wt. gear oil.



# Sanding Belts

You can greatly increase the lifespan of your sanding belts if you clean them often. As mentioned on **Page 24**, cleaning pads are the fastest way to remove saw dust build-up.

## Air System

The air system is durable and reliable; however, components do wear with age. If you suspect that an item in your air system may be having problems, see the **Air System Diagram** on **Page 37**.

- Adjust regulator to 75 PSI.
- Carefully inspect all air lines for cracks, tears or hardening. Replace faulty hoses.
- Check the air connections for leaks. A small amount of soapy water in a questionable area will bubble if there is a leak.
- Make sure lines are not clogged. Remove a questionable line and blow through it as a test.

### CAUTION

If a component in the air system is malfunctioning, bleed all air from the system, and fix the problem before you resume sanding.

# Dust and Water Traps

There are three collection traps on this wide belt sander. One water trap is attached to the bottom of the air regulator, and two dust traps are attached on the air diaphragm assemblies. Cleaning is easy, with the system under air pressure, you can push the lower drain valve and empty the water trap (**Figure 22**). Replace the internal white moisture filters yearly. To empty the dust trap bowls, relieve the air pressure and then unscrew and empty the bowls (**Figure 23**). DO NOT allow the water trap and dust bowls to become full.

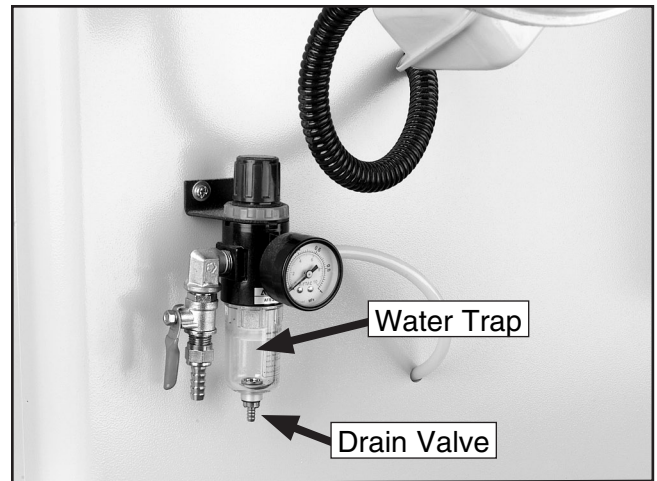

**Figure 22.** Water trap on the regulator.

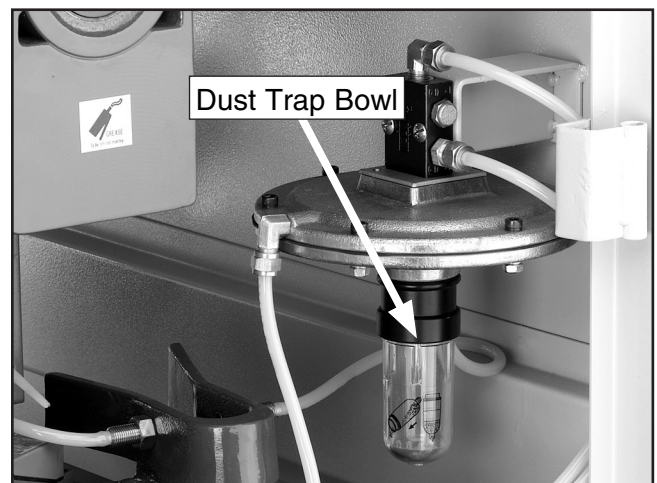

**Figure 23.** Unscrew the clear canister to empty the air line dust trap.



# SECTION 7: SERVICE

## Table Calibration

### **NOTICE**

The digital thickness gauge has been calibrated at the factory and should require no further adjustment. However, we recommend verifying its accuracy.

Use the first board fed through the sander to test the accuracy of the digital thickness gauge.

#### To calibrate the digital thickness scale:

1. Using a properly set-up planer, plane a board to uniform thickness.
2. Lower the sander table far enough to place the planed board under the sander roller.
3. Manually raise the table until the board just touches the sanding roller.
4. Remove the board without changing the table height. This ensures the table will be properly adjusted for the first sanding pass.
5. Run the board through the sander several times at the initial height setting. Manually raise the table 0.020" and pass the board through the sander several more times. Monitor the amperage meter and the resulting load on the sander.
6. Measure the thickness at various points around the board using a precise micrometer or set of calipers. Continue sanding the board at that height until the average thickness measurement is within  $\pm 0.003$ ".

**Note:** *These final passes should be done without adjusting the table height. This ensures the most consistent average thickness.*

7. Observe the digital display read-out, it should indicate the average thickness of the sanded wood.

—If it does, the sander is properly calibrated and accurate to the nearest 0.005".

—If it does not, you must recalibrate the digital thickness scale.

#### To recalibrate the digital thickness scale:

1. Without moving the table height, enter the numerical measurement of the average thickness of the sanded wood into the digital key pad on the control panel.

**Note:** *The average thickness of the sanded wood should now be flashing on the digital read-out.*

2. Press and hold the  key until the display stops flashing. The sander is now correctly calibrated.

## Platen Service

#### To replace the platen felt and graphite pad:

1. DISCONNECT THE SANDER FROM THE POWER SOURCE!
2. Open the left access door, and use the platen tool, as shown in **Figure 24**, to remove the platen.
3. Replace platen felt pad and graphite pad.
4. Reinsert the platen until it stops.
5. Close the access door.



**Figure 24.** Removing platen.



# Brake Service

Tools Needed:	Qty
14mm Open End Wrench .....	1
Small Snap Ring Pliers .....	1
6mm Hex Wrench.....	1
#2 Phillips Screwdriver .....	1

Eventually the brake pads will wear out. Checking and replacing these is a simple project that can be done in the shop, with the exception of having the rotor resurfaced on a lathe.

## To check the brake pads:

1. DISCONNECT THE SANDER FROM THE POWER SOURCE AND REMOVE AIR PRESSURE COMPLETELY!
2. Remove the four screws that secure the access panel on the right-hand side of the machine.
3. The brake caliper is located underneath the rotor in **Figure 25**, which is attached to the motor arbor.



**Figure 25.** Disc brake.

4. The brake pads consist of a metal plate with a composite pad. With a fine ruler, measure the thickness of the composite pad only. If one of the pads is below  $\frac{1}{8}$ " (approx. 3mm), replace both.

## To replace the brake pads:

1. DISCONNECT THE SANDER FROM THE POWER SOURCE AND REMOVE AIR PRESSURE COMPLETELY!
2. Remove the nuts from the two mounting bolts and the two snap rings on the mounting pins behind the bracket.
3. Pull the mounting pins out of the caliper bracket and remove the air line from the caliper. The caliper should now be able to be removed.
4. Disassemble the brake caliper and remove the cap screws securing the brake pads.
5. Remove the brake rotor and have it professionally resurfaced at an automotive machine shop if it has gouges in it. If visible cracks are present in the brake rotor, replace it with a new one. Remove oil and dirt from the rotor with automotive brake cleaner. Once clean, only handle the rotor with a dry rag and install exactly the reverse of removal.
6. Install new brake pads, mount the caliper and reconnect the air line.
7. Test the safety shutdown operation by running the sander and pressing the emergency stop controls.



# Oscillation Timing

## NOTICE

The oscillation adjustments have been performed at the factory and should require no further attention. However, we recommend verifying the settings.

When the oscillation is correctly adjusted, the sanding belt oscillates to the left and to the right at the same speed. If the sanding belt makes contact with a limit switch, as shown in **Figure 26**, the emergency braking system will activate and stop the sander immediately.

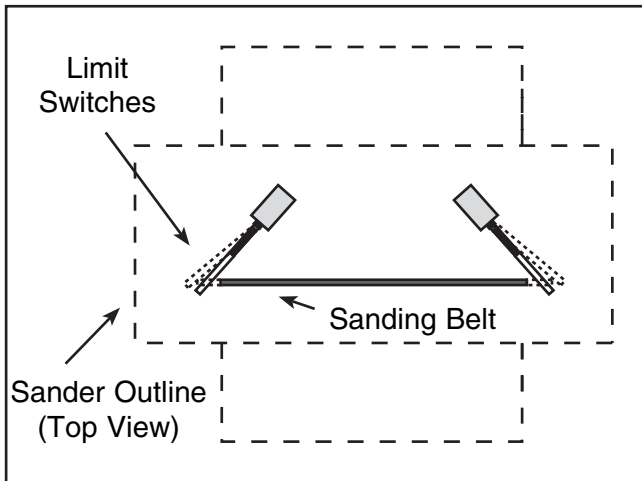

Figure 26. Improper oscillation.

### To check the sanding belt oscillation:

1. Be sure the sanding belt is properly installed and the belt tension knob and air supply are **ON**.
2. Turn **ON** the sanding belt.

—If the belt oscillates without contacting the limit switches, but the oscillation time to the left and right are **NOT** equal, proceed to **Step 5**, on **Page 30**.

—If the belt tracks away from the air fork and air jet, triggering into the limit switch, continue with **Step 3**.

3. An adequate stream of air through the air fork gap (**Figure 27**) is essential for proper oscillation. If the jet of air is weak through the gap, the belt will track away from the controller and into the limit switch on the opposite end of the roller. The pivot action of the upper roller, and the resulting oscillation of the belt, are dependent upon adequate airflow through the air fork gap.

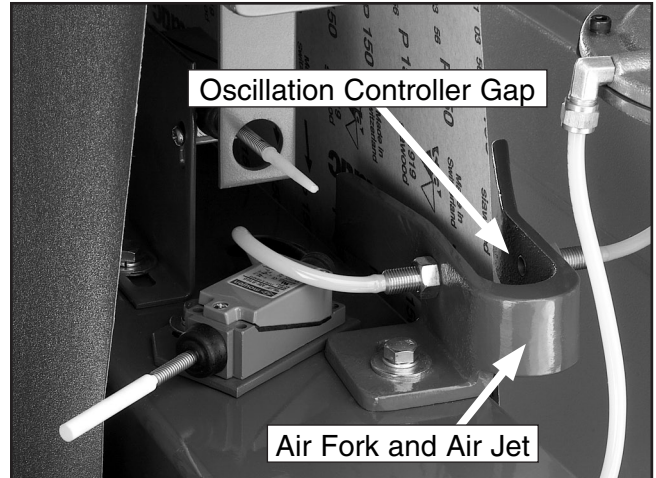

Figure 27. Oscillation components.

### To set the correct amount of airflow through the air fork gap:

1. Remove the sanding belt then turn the belt tension knob to the tensioned position.
2. Loosen the lock nut on the airflow adjustment knob (**Figure 28**).
3. Turn the airflow adjustment knob (**Figure 28**) clockwise until the airflow is completely **OFF**. The upper roller should pivot to the right.
4. Slowly turn the airflow adjustment knob counterclockwise, and continue turning up the air pressure until the roller pivots to the left.

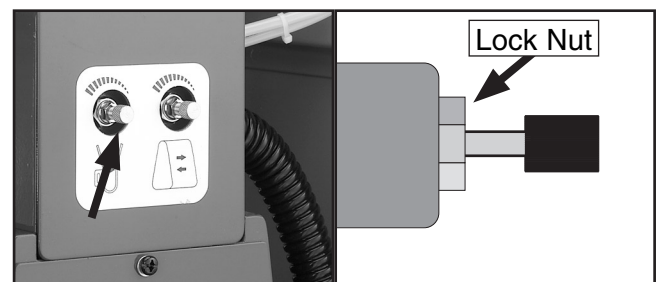

Figure 28. Airflow adjustment knob.



5. Tighten the lock nut (**Figure 28**) to secure the airflow adjustment knob.
6. Restrict the airflow across the air fork gap with a scrap piece of wood. You should notice the roller pivot to the right. When the stick is removed, the roller should pivot back to the left.
7. Test the oscillation by running the sander. Make note of the time it takes for the belt to oscillate from left-to-right and from right-to-left.

When correctly timed, the oscillation should take a similar amount of time to oscillate.

—If the oscillation time to the **right** is 2 seconds, but the oscillation time to the **left** is longer, loosen the oscillation adjustment knob (**Figure 29**) and move it to the **left** until proper tracking is achieved. Tighten down the oscillation adjustment knob when satisfied.

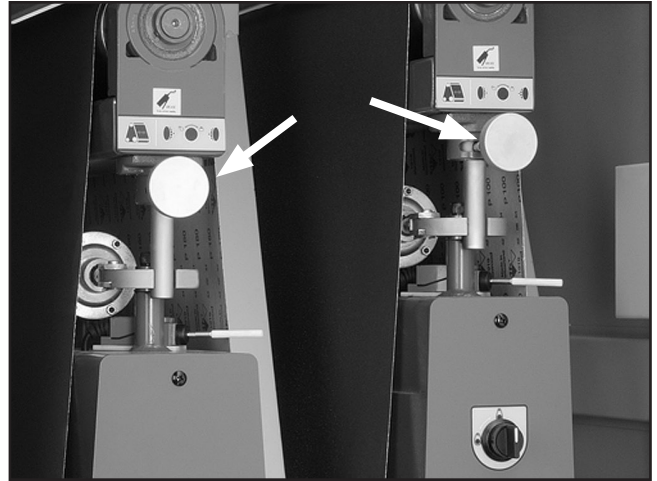

**Figure 29.** Oscillation adjustment knobs.

—If the oscillation time to the **left** is 2 seconds, but the oscillation time to the **right** is longer, loosen the oscillation adjustment knob and move it to the **right** until proper tracking is achieved. Tighten the oscillation adjustment knob when satisfied.

8. Continue to the next page to adjust the oscillation speed.



# Oscillation Speed

The oscillation speed of the sanding belt is adjustable. Different oscillating speeds yield different sanding results. We recommend trying various speeds on a scrap piece of wood similar to the final workpiece.

## To adjust the oscillation speed:

1. Loosen the lock nut on the speed control adjustment knob (**Figure 30**).

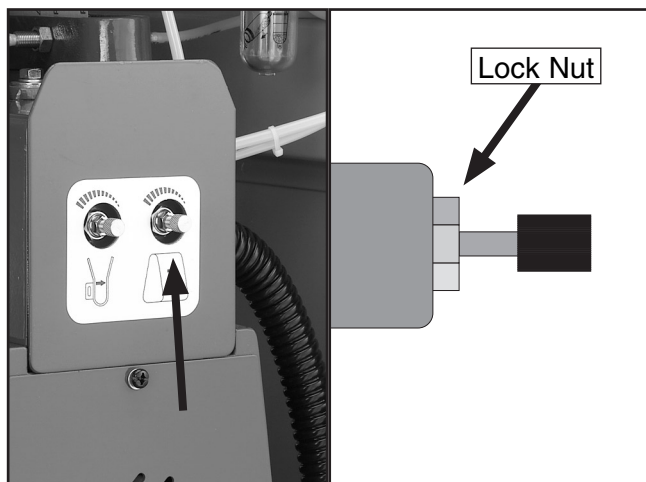

**Figure 30.** Speed control adjustment knob.

2. Turn the knob clockwise to decrease the oscillation speed and counterclockwise to increase it.
3. Tighten the lock nut loosened in **Step 1** to secure the knob.

# Table Parallelism

## ***NOTICE***

The table has been adjusted at the factory and should require no further attention. However, we recommend verifying that it is parallel with the sanding roller.

The corners of the table can be independently adjusted up or down. By disconnecting the chain and turning the pertinent table elevation screw sprocket, (**Figure 31**) table parallelism can be achieved.

Adjusting the table parallelism can be a very tedious task that takes a great amount of patience. DO NOT adjust the table unless you are having trouble sanding your workpiece to a uniform thickness.

If a table adjustment is needed, take precise notes on the positioning of the table elevation screws. This will allow the original setting to be re-established.

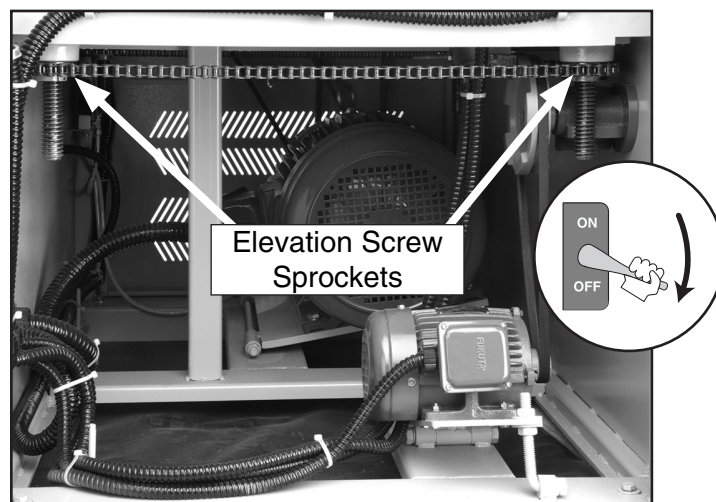

**Figure 31.** View of elevation screw sprockets.



## To adjust the table parallelism:

1. Pass the widest size board your machine will allow through the sander until the **entire** surface of the board is making contact with the sanding belt.
2. Measure the thickness of the board at various points around the edge.
3. If there is a variation of thickness, the table can be adjusted accordingly.
4. DISCONNECT THE SANDER FROM THE POWER SOURCE!

—For minor adjustment, loosen the table mounting bolts shown in **Figure 32** and rotate the elevation screw flange.

—For major adjustment, mark the chain location on all sprockets, remove the chain from the sprocket to be adjusted, and turn the sprocket counterclockwise to raise the table. One quarter of a turn raises or lowers an elevation screw approximately 0.020"

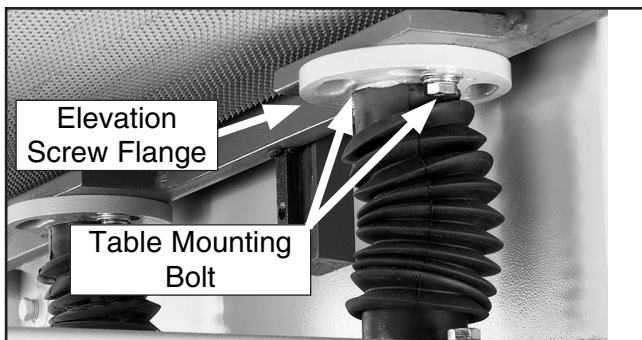

**Figure 32.** Table mounting bolts.

## **NOTICE**

**When adjusting the left front elevation screw, make the same adjustment to the left rear elevation screw. This ensures the height from the front to the back of the table remains unchanged. Do the same when adjusting the right elevation screws.**

5. Reinstall the chain onto the sprocket adjusted in **Step 4**, tighten the bolts, and test the machine.

# Pressure Rollers

## To adjust the pressure rollers:

1. DISCONNECT THE SANDER FROM THE POWER SOURCE!
2. Plane a 6' long 2x4 to a uniform thickness and cut it in half. Place one board along the length of the feed belt on the right-hand side and place the other board on the left-hand side.
3. With the sanding belt tensioned (**Figure 33**), move the sanding rollers by hand and manually raise the table until you hear the sandpaper just contact the surface of the wood. DO NOT continue to raise the table beyond that point.

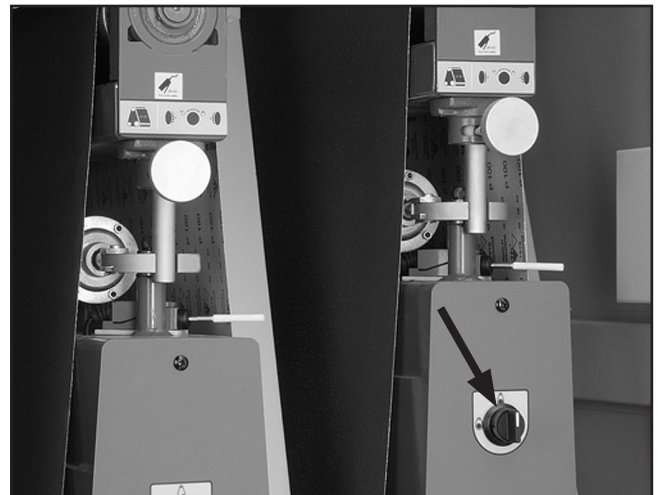

**Figure 33.** Belt tension knob.

4. Connect the sander to the power source and make note of the reading on the digital display. Then manually lower the table 0.020" to 0.030". This is how much lower the infeed pressure roller should be set when compared to the sanding surface of the sanding roller.
5. DISCONNECT THE SANDER FROM THE POWER SOURCE!



- Loosen the infeed pressure roller lock nuts (**Figure 34**) on the infeed pressure roller. Turn the adjustment studs (**Figure 34**) to lower the infeed pressure roller until it just touches the board.

**Note:** *DO NOT continue to lower the roller beyond that point.*

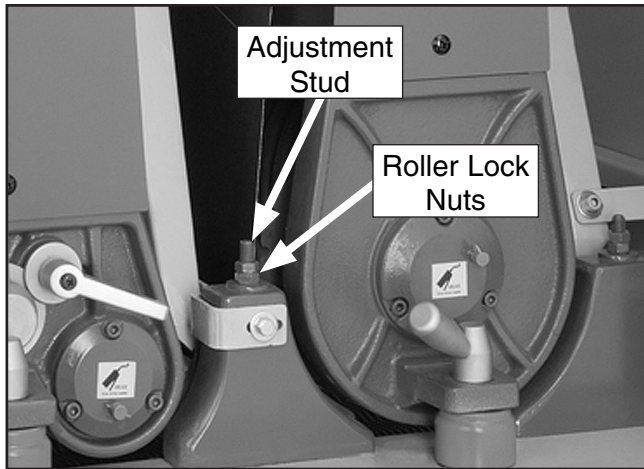

**Figure 34.** Pressure roller adjustment location.

- Tighten the roller lock nuts and recheck your settings.
- Connect the sander to the power source and make note of the reading on the digital display. Then manually lower the table an additional 0.020" to 0.030". This is how much lower the outfeed pressure roller should be set when compared to the height of the infeed roller.
- Loosen the roller lock nuts on the outfeed pressure roller. Turn the adjustment bolts to lower the pressure roller until it just touches the board.

**Note:** *DO NOT continue to lower the roller beyond that point.*

- Tighten the roller lock nuts and recheck your settings.

**Note:** *Variables such as feed rate, depth of the cut, and the type of sanding belt can play a big part in determining the proper amount of downward pressure exerted by the rollers. Some experimentation may be necessary to achieve the desired results. However, under no circumstances should the pressure rollers be set even, or higher than, the sanding roller.*

G0486/G0487 Wide Belt Sander

## V-Belt Adjustment

**To adjust either V-belt:**

- DISCONNECT THE SANDER FROM THE POWER SOURCE!
- Loosen the lock nut (**Figures 35 & 36**).

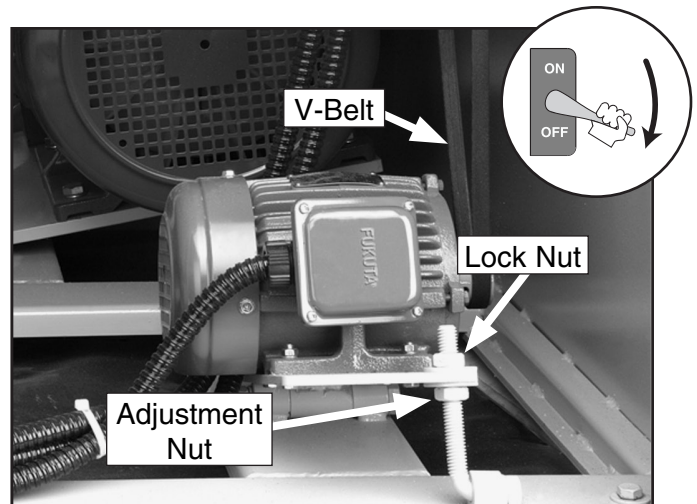

**Figure 35.** Table elevation V-belt.

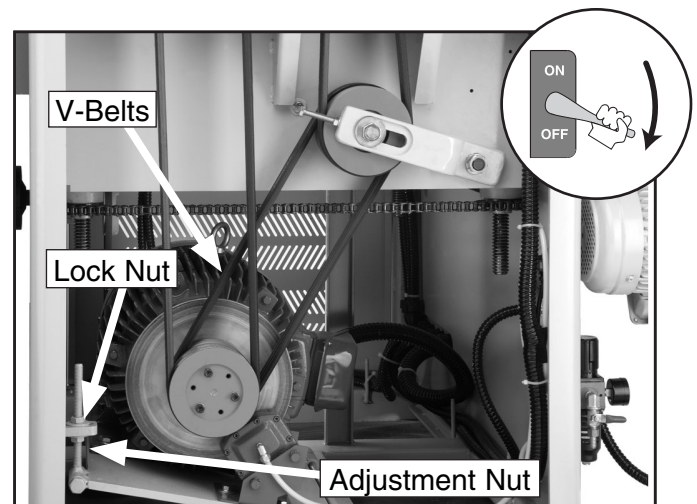

**Figure 36.** Sanding drum V-belts.

- Turn the adjustment nut up or down until the V-belts deflect 1" off of center when pushed with your finger.
- Retighten the lock nut.



# Conveyor Belt Replacement

## Tools Needed: Qty

Make sure that you have a lifting device or another person to help in table removal.

9 mm Hex Wrench.....	1
19 mm Combination Wrench.....	1
12 mm Combination Wrench.....	1
14 mm Combination Wrench.....	1
#2 Phillips Screwdriver .....	1
8' 2x4s .....	2
Permanent Marker .....	1

**To remove the conveyor belt, use Figure 38 and match the number with the steps below:**

1. Raise the table up so the conveyor belt is approximately two-inches away from the sanding roller or platen, and then **DISCONNECT THE SANDER FROM THE POWER SOURCE!**
2. Remove the gearbox mounting bracket, and with an assistant's help, slide the motor and gearbox from the roller shaft and lower it to the floor.  
  
**Note:** Do not loosen the two vibration dampener washers shown in **Figure 38**.
3. Remove two table height limit switches.
4. Remove both lower access panels.
5. Remove the left and right table guides.
6. Using a permanent marker, mark all four lead screw flange positions (**Figure 37**), and remove all hex bolts from the flanges.

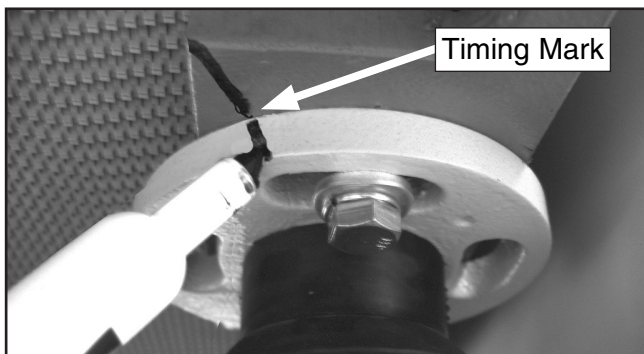

**Figure 37.** Marking lead screw for reassembly.

7. Insert two 2x4 x 8' wooden studs under the table to support the table, and then (with help) lift the table slightly and move it out of the rear of the machine.
8. Disconnect the limit switch, remove all mounting screws, and remove the emergency stop push-panel assembly.
9. Turn both tracking adjustment bolts counter-clockwise five turns, remove one roller support, and slide the drum out of the table assembly.
10. Remove the old conveyor belt, inspect rollers, bearings, and table for wear and replace as required.
11. Install the new conveyor belt. **Note:** *The belt is non-directional.*
12. Install the front roller, the roller support, and turn both tracking adjustment bolts clockwise equally so the conveyor belt becomes taut and does not hang loose. **DO NOT OVERTIGHTEN** the belt.
13. With a helper, install the table from the rear in a similar fashion as it was removed.
14. Install the table guides and the left and right lower access panels.
15. Align the lead screw flanges with the marks made in **Step 6**, and install the hex bolts.
16. Install the table height limit switches so the upper switch clicks when the conveyor surface is 1/4" away from the sandpaper, and the lower switch clicks when the conveyor table is 1/4" higher than its lowest position. Make sure that you manually test your settings with the hand wheel so you don't crash the table if incorrectly set.
17. With a helper, install the gearbox, vibration dampener washers, and mounting bracket.
18. Install the emergency stop push panel assembly and the limit switch.
19. Start the conveyor motor and turn the conveyor tracking bolts as required until the conveyor belt tracks straight without loading up on one side of the table.



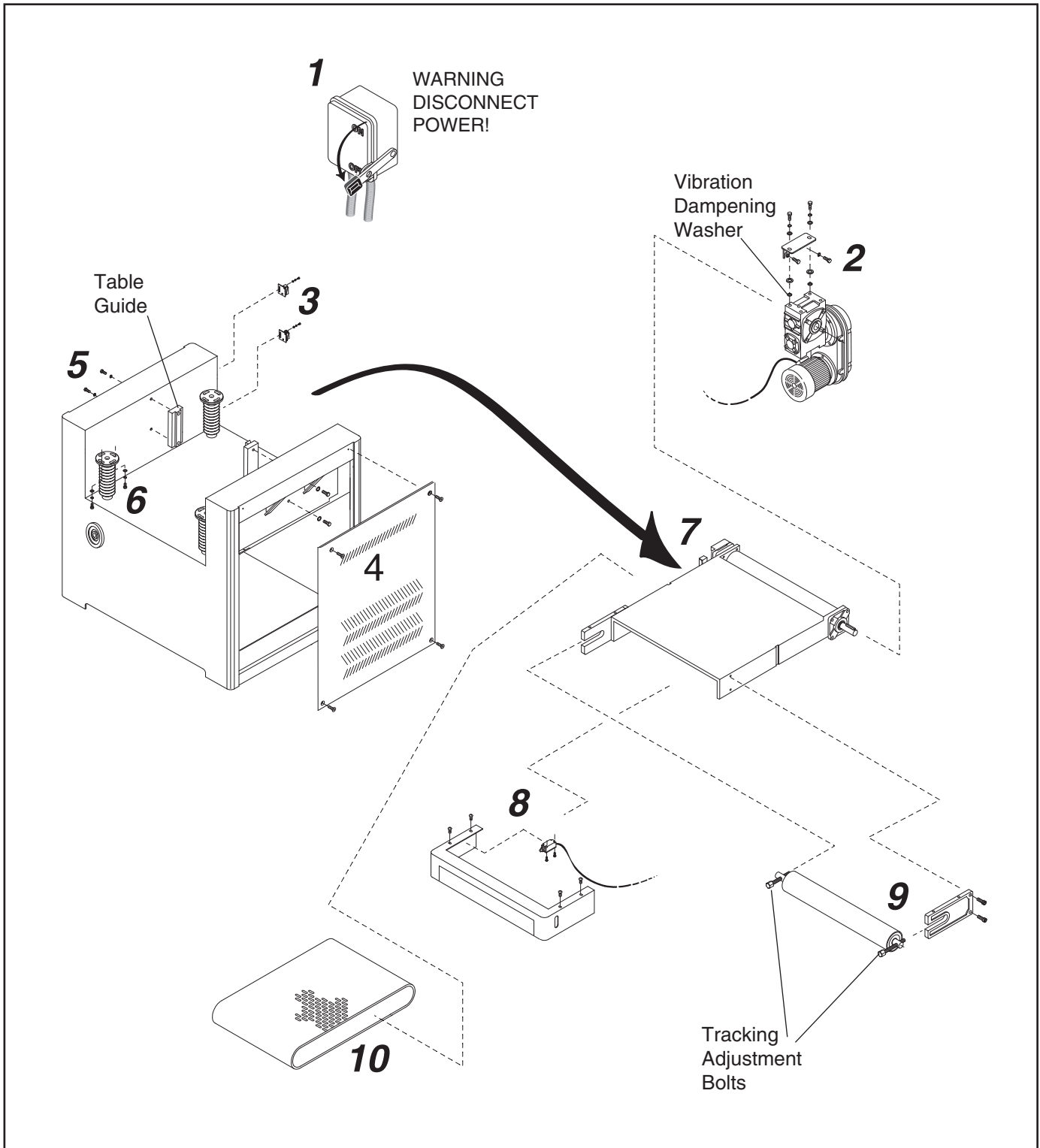

**Figure 38.** Conveyor belt removal sequence.



# Feed Belt Tension

Tools Needed:	Qty
Wrench or Socket 20mm.....	1
Phillips Screwdriver #2.....	1

## To adjust the feed belt tension:

1. DISCONNECT THE SANDER FROM THE POWER SOURCE!
2. **Do not remove the safety guard!**
3. Find the adjustment ports in the safety guard (**Figure 39**) at the front end of the feed table.
4. Turn both left and right adjustment bolts (**Figure 39**) clockwise equally to increase tension.

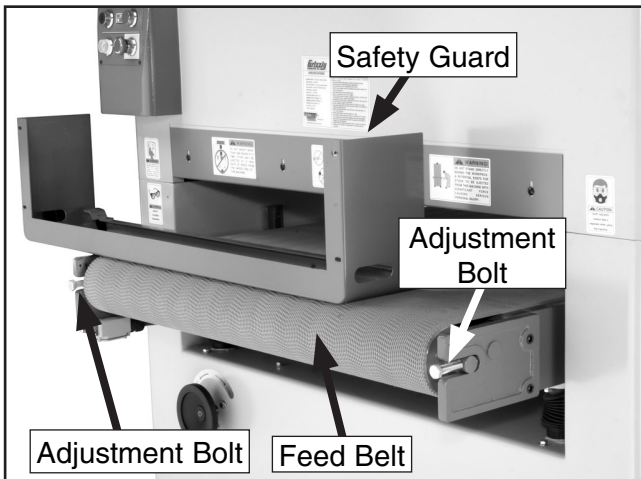

**Figure 39.** Feed belt tension adjustment bolts.

**Note:** Safety guard removed only for clarity.

5. When tensioned properly you should not be able to lift the feed belt off of the table surface or slide it back and forth.

## **!WARNING**

**DO NOT sand boards with the guard removed. Failure to follow this warning could result in serious personal injury.**

# Feed Belt Tracking

Tools Needed:	Qty
Hex Wrench 6mm.....	1

## **NOTICE**

**Adjust the feed belt tension before adjusting the feed belt tracking.**

## To adjust the feed belt tracking:

1. Turn the feed belt **ON**.
2. If the feed belt is tracking to the **right** side of the table, turn the **right** adjustment bolt (**Figure 39**) clockwise.
3. If the feed belt is tracking to the **left** side of the table, turn the **left** adjustment bolt clockwise.

**Note:** The edge of the feed belt should just touch the guide wheels as shown in **Figure 40**.

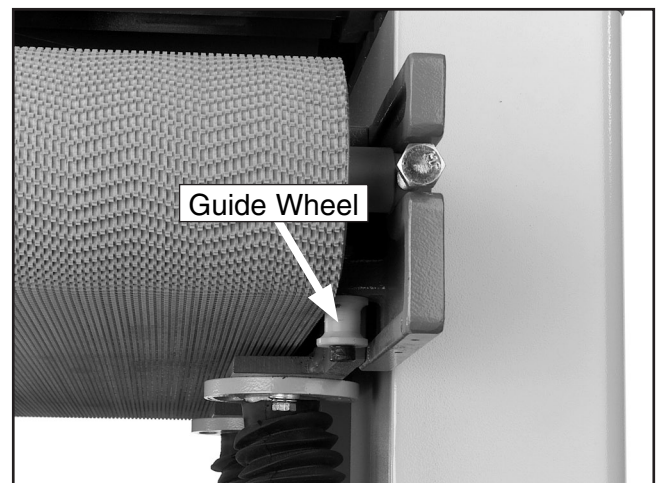

**Figure 40.** Guide wheels.

4. Run the feed belt for 3-5 minutes and recheck the tracking.
5. If the belt is still tracking correctly, replace the safety guard removed in the previous subsection.



# Air System Diagram

- |   |  |
|---|--|
| <ul style="list-style-type: none"> <li><b>A.</b> Shop Compressor</li> <li><b>B.</b> Air Pressure Regulator</li> <li><b>C.</b> Emergency Brake Solenoid</li> <li><b>D.</b> Emergency Brake</li> <li><b>E.</b> Air Distribution Manifold</li> <li><b>F.</b> Airflow Adjustment Knob<br/>(Oscillation Timing)</li> <li><b>G.</b> Speed Control Adjustment Knob<br/>(Oscillation Speed)</li> <li><b>H.</b> Oscillation Controller Air Fork</li> </ul> | <ul style="list-style-type: none"> <li><b>I.</b> Oscillation Timing Piston and Diaphragm Assy.</li> <li><b>J.</b> Oscillation Speed Control Piston</li> <li><b>K.</b> Belt Tension Control Piston</li> <li><b>L.</b> Belt Tension Control Switch</li> <li><b>M.</b> Emergency Stop Button Switch</li> <li><b>N.</b> Emergency Stop Push Brake Switch</li> <li><b>O.</b> Left Belt Limit Switch</li> <li><b>P.</b> Right Belt Limit Switch</li> <li><b>Q.</b> Belt Tension Limit Switch</li> <li><b>R.</b> Emergency Brake Contactor</li> </ul> |
|---|--|

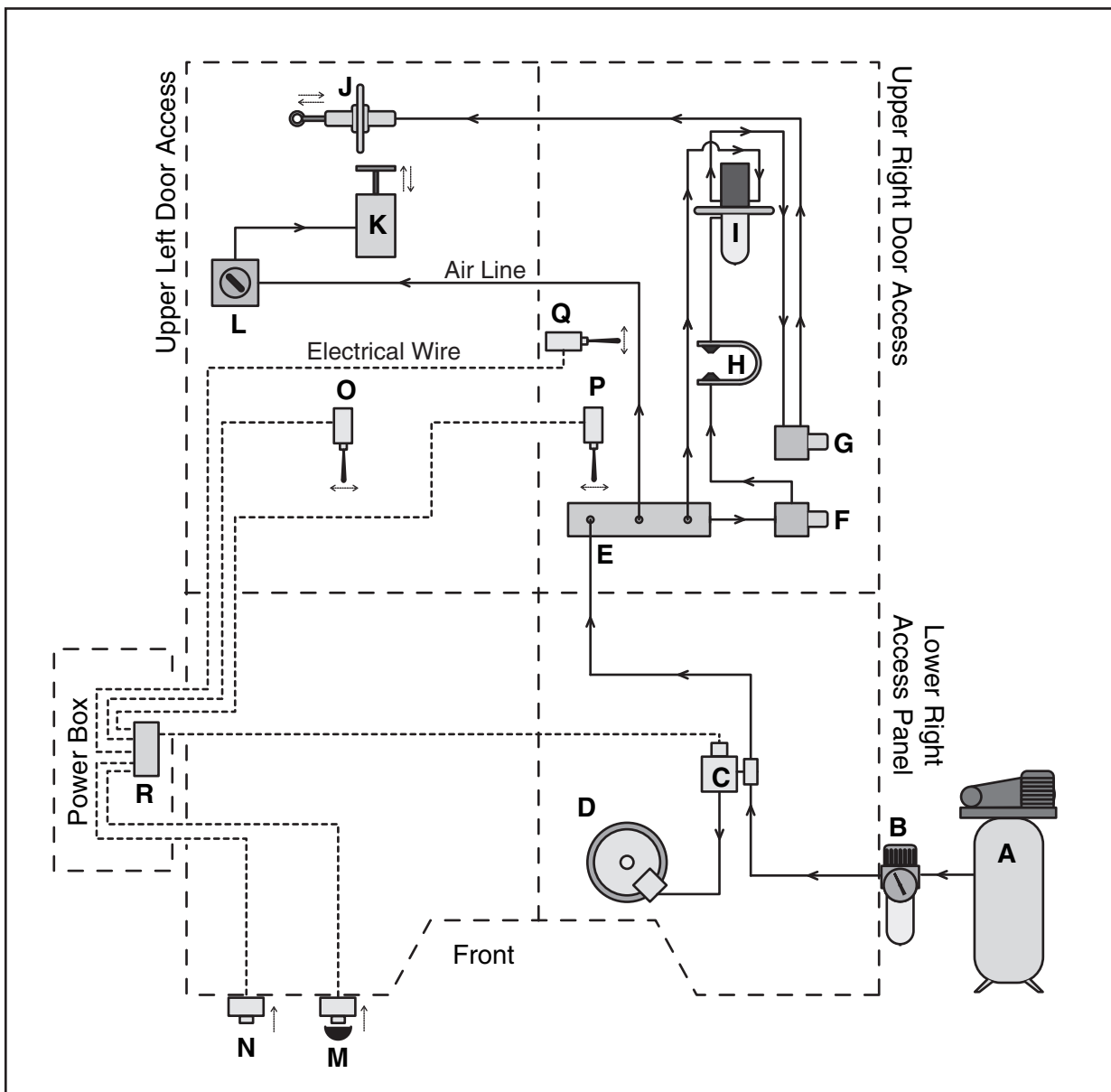

Review the troubleshooting and procedures in this section to fix your machine if a problem develops. If you need replacement parts or you are unsure of your repair skills, then feel free to call our Technical Support at (570) 546-9663.

# Troubleshooting

## Motor & Electrical

Symptom	Possible Cause	Possible Solution
Motor will not start.	<ol style="list-style-type: none"> <li>1. Limit switch or emergency stop is at fault.</li> <li>2. Low voltage.</li> <li>3. Open circuit in motor or loose connections.</li> </ol>	<ol style="list-style-type: none"> <li>1. Correct situation that caused limit switch to engage, reset the emergency stop button.</li> <li>2. Check power line for proper voltage.</li> <li>3. Inspect all lead connections on motor for loose or open connections.</li> </ol>
Motor will not start; fuses or circuit breakers blow.	<ol style="list-style-type: none"> <li>1. Short circuit in line cord or plug.</li> <li>2. Short circuit in motor or loose connections.</li> <li>3. Incorrect fuses or circuit breakers in power line.</li> </ol>	<ol style="list-style-type: none"> <li>1. Inspect cord or plug for damaged insulation and shorted wires.</li> <li>2. Inspect all connections on motor for loose or shorted terminals or worn insulation.</li> <li>3. Install correct fuses or circuit breakers.</li> </ol>
Motor overheats.	<ol style="list-style-type: none"> <li>1. Motor overloaded.</li> <li>2. Air circulation through the motor restricted.</li> </ol>	<ol style="list-style-type: none"> <li>1. Reduce load on motor.</li> <li>2. Clean out motor to provide normal air circulation.</li> </ol>
Motor stalls (resulting in blown fuses or tripped circuit).	<ol style="list-style-type: none"> <li>1. Short circuit in motor or loose connections.</li> <li>2. Low voltage.</li> <li>3. Incorrect fuses or circuit breakers in power line.</li> <li>4. Motor overloaded.</li> </ol>	<ol style="list-style-type: none"> <li>1. Inspect connections on motor for loose or shorted terminals or worn insulation.</li> <li>2. Correct the low voltage conditions.</li> <li>3. Install correct fuses or circuit breakers.</li> <li>4. Reduce load on motor.</li> </ol>

## Machine Operations

Symptom	Possible Cause	Possible Solution
Machine slows when operating.	<ol style="list-style-type: none"> <li>1. Feed rate too high.</li> <li>2. Depth of cut too great.</li> </ol>	<ol style="list-style-type: none"> <li>1. Feed workpiece slower.</li> <li>2. Reduce depth of cut.</li> </ol>
Loud, repetitious noise coming from machine.	<ol style="list-style-type: none"> <li>1. Pulley set screws or keys are missing or loose.</li> <li>2. Motor fan is hitting the cover.</li> <li>3. V-belt is defective.</li> </ol>	<ol style="list-style-type: none"> <li>1. Inspect keys and set screws. Replace or tighten if necessary.</li> <li>2. Tighten fan or shim cover.</li> <li>3. Replace V-belt. Refer to the <b>Maintenance</b> section.</li> </ol>
Machine is loud, overheats or bogs down in the cut.	<ol style="list-style-type: none"> <li>1. Excessive depth of cut.</li> <li>2. Dull or dirty sanding belt.</li> </ol>	<ol style="list-style-type: none"> <li>1. Decrease depth of cut.</li> <li>2. Replace or clean sanding belt.</li> </ol>
Rounded workpiece edges.	<ol style="list-style-type: none"> <li>1. Excessive depth of cut.</li> </ol>	<ol style="list-style-type: none"> <li>1. Reduce depth of cut.</li> </ol>
Uneven thickness from left to right of board.	<ol style="list-style-type: none"> <li>1. Feed table not parallel to sanding roller.</li> <li>2. Conveyor belt is worn.</li> </ol>	<ol style="list-style-type: none"> <li>1. Adjust the table.</li> <li>2. Replace conveyor belt.</li> </ol>
Workpiece slips on feed belt.	<ol style="list-style-type: none"> <li>1. Pressure rollers set too high.</li> <li>2. Dirty conveyor belt.</li> <li>3. Conveyor belt is worn.</li> </ol>	<ol style="list-style-type: none"> <li>1. Lower pressure rollers.</li> <li>2. Clean conveyor belt.</li> <li>3. Replace conveyor belt.</li> </ol>
Straight strip of notches on workpiece.	<ol style="list-style-type: none"> <li>1. Pressure rollers are dirty or damaged.</li> </ol>	<ol style="list-style-type: none"> <li>1. Clean or repair pressure rollers.</li> </ol>
Snake shaped marks on workpiece.	<ol style="list-style-type: none"> <li>1. Sanding belt damaged or dirty.</li> </ol>	<ol style="list-style-type: none"> <li>1. Clean or replace sanding belt.</li> </ol>



# Troubleshooting

Symptom	Possible Cause	Possible Solution
Lines across width of workpiece.	1. Sanding belt seam is open or damaged.	1. Repair or replace sanding belt.
Glossy spots or streaks on workpiece.	1. Worn sanding belt. 2. Rear pressure roller too low.	1. Replace sanding belt. 2. Raise rear pressure roller. <b>(See warning in Pressure Roller section, Page 18!)</b>
Sanding belt clogs quickly.	1. Sanding belt grit too small for particular job. 2. Excessive depth of cut. 3. Wood is too moist.	1. Replace with a coarser grit sanding belt. 2. Reduce depth of cut. 3. Allow wood to dry out.
Sanding belt does not tension correctly; rollers slip under belt.	1. Low air pressure. 2. Air leaks in system.	1. Adjust air pressure to 75 PSI at primary regulator. 2. Inspect all hoses and connections for leaking air; use water on suspected area to detect bubbles.
Sanding belt runs off to one side, stopping the sander.	1. Air eye fork clogged. 2. Oscillation return valve closed. 3. Oscillation timing incorrect.	1. Clean the intake hole on the air eye fork. 2. Open valve. 3. Adjust oscillation timing.
Sanding belt will not start.	1. Sanding belt is not tensioned. 2. Limit switches engaged. 3. Emergency stop plate engaged.	1. Tension sanding belt. 2. Center sanding belt so it is not touching the limit switches. 3. Make sure emergency stop switch is released.
Poor, non-aggressive sanding results.	1. Worn sanding belt. 2. Sanding belt loaded with sawdust.	1. Replace sanding belt with a new one. 2. Clean sanding belt to unload sawdust.
Conveyor belt not tracking in center.	1. Conveyor rollers moved out of adjustment.	1. Re-adjust conveyor rollers.
Conveyor belt slipping.	1. Conveyor rollers have incorrect tension. 2. Conveyor rollers contaminated with dirt or dust.	1. Adjust conveyor rollers to place more tension on the workpiece. 2. Clean conveyor rollers.
Emergency brake stops slow.	1. Air pressure incorrect. 2. Air leak in system. 3. Brake rotor contaminated with oil. 4. Brake pads worn out.	1. Adjust air pressure to 75 PSI. 2. Find and fix air leaks. 3. Clean brake rotor with automotive brake parts cleaner. 4. Replace brake pads.
Grinding noise when braking.	1. Brakes severely worn out.	1. Replace brake pads, have rotor turned (possibly replaced).

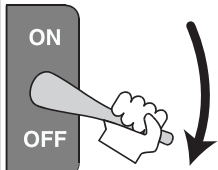

**⚠ WARNING**

**For your safety, turn the power switch off and disconnect the sander from the power source and the air supply before starting the applicable troubleshooting.**



# Control Panel Component Locations (G0486/G0487)

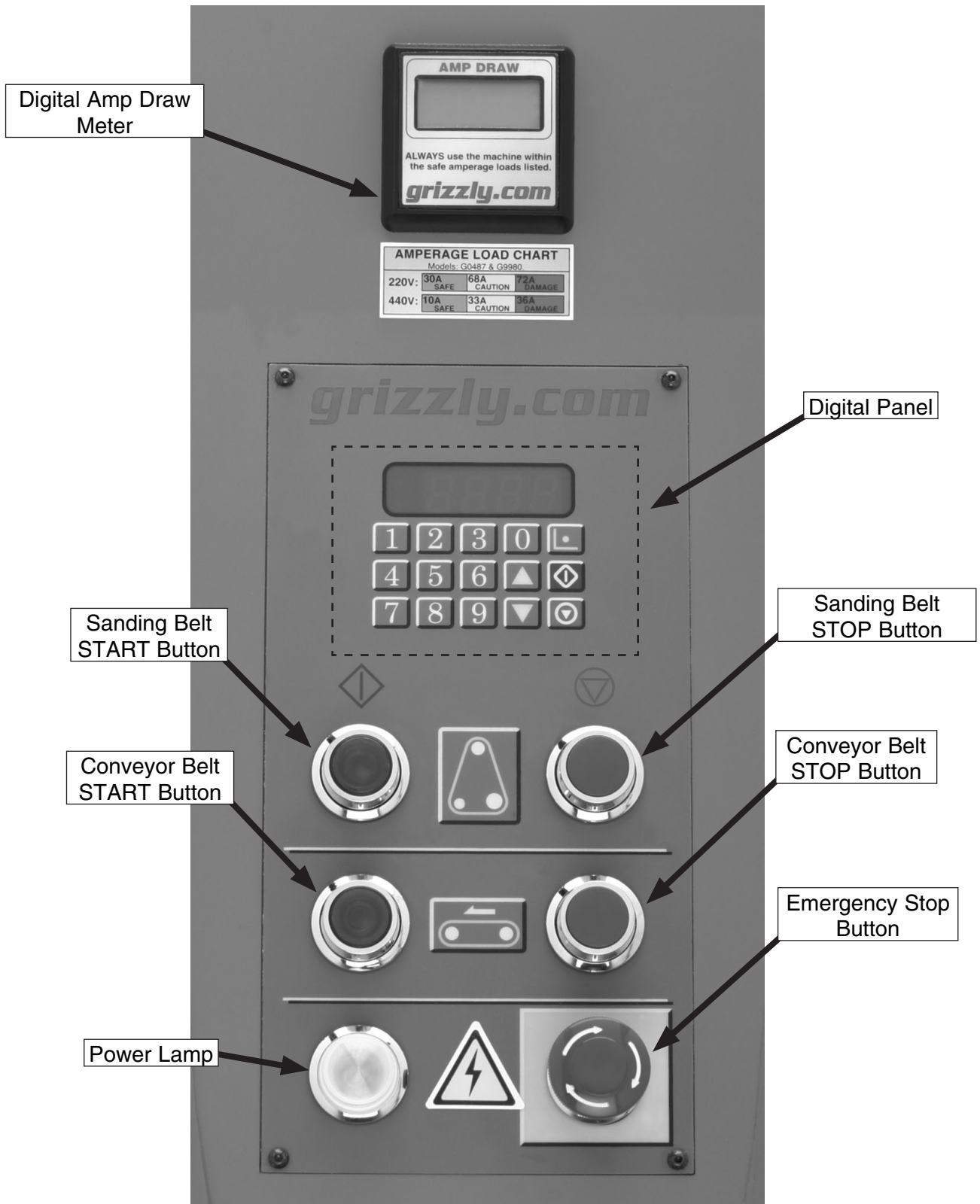

# General Control Panel Electrical Diagram (G0486/G0487)

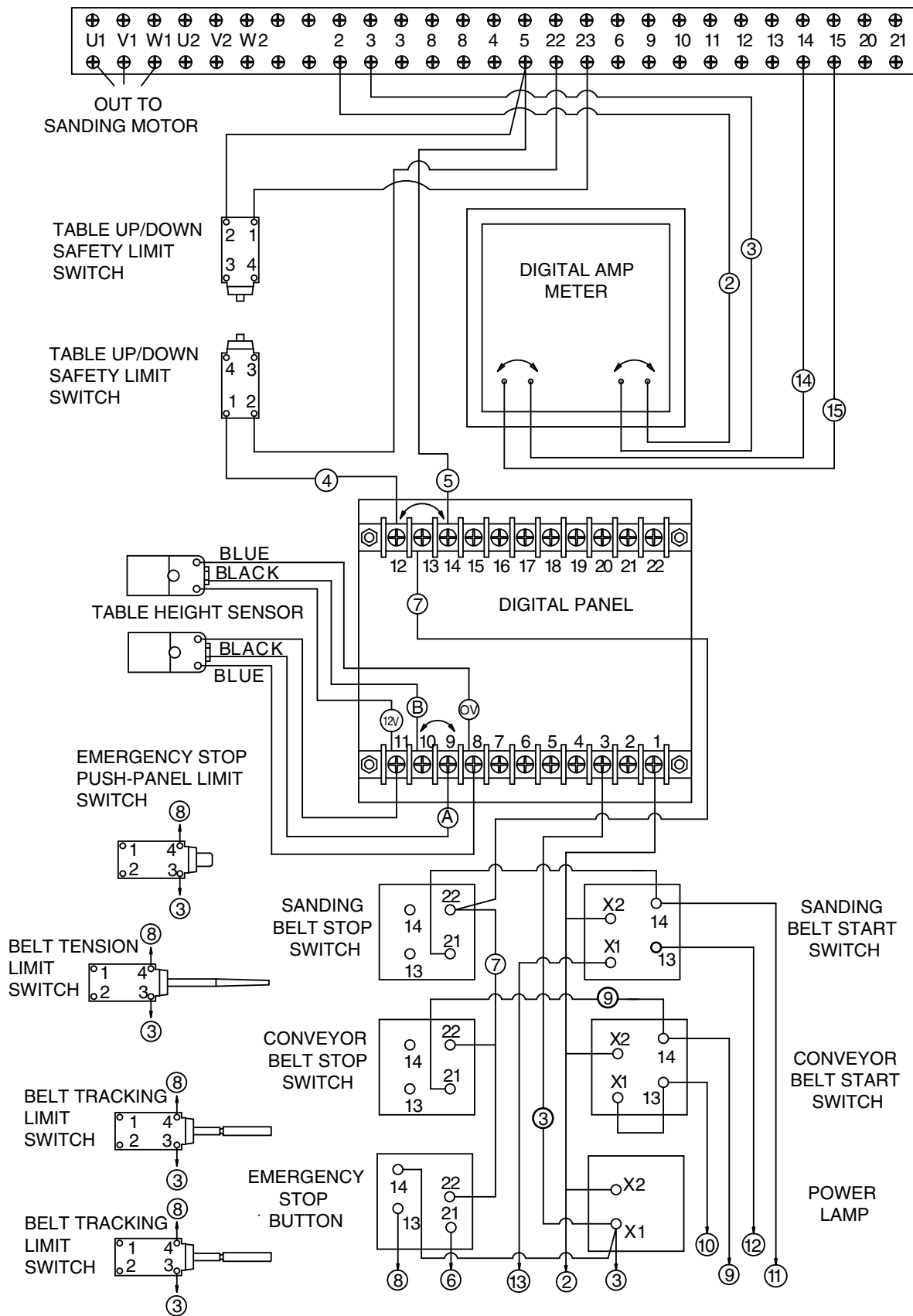



# Wiring Box Components (G0486 220V/440V, G0487 440V)

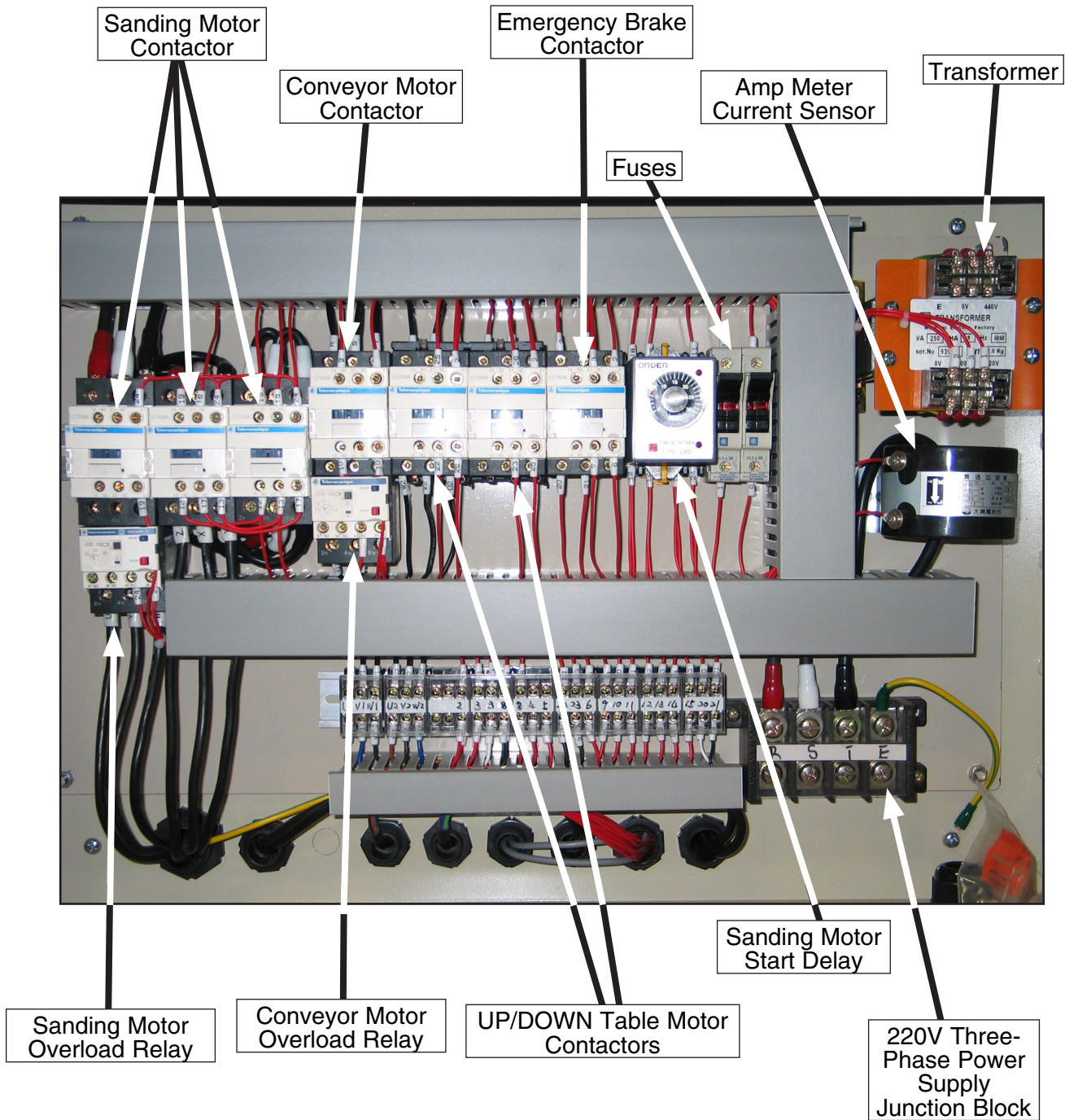

# Wiring Box Electrical Diagram (G0487 220V)

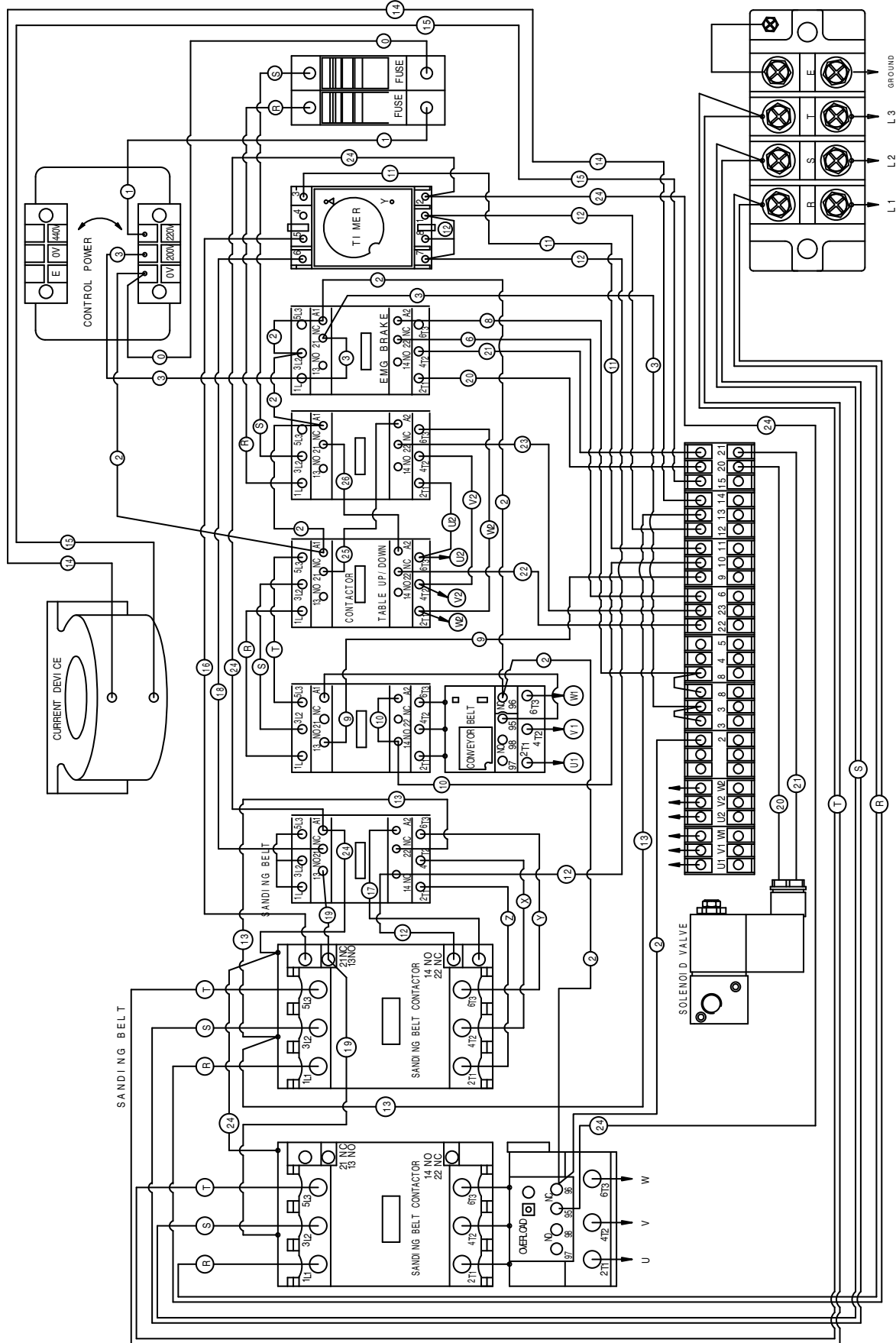

# Wiring Box Components (G0487 220V)

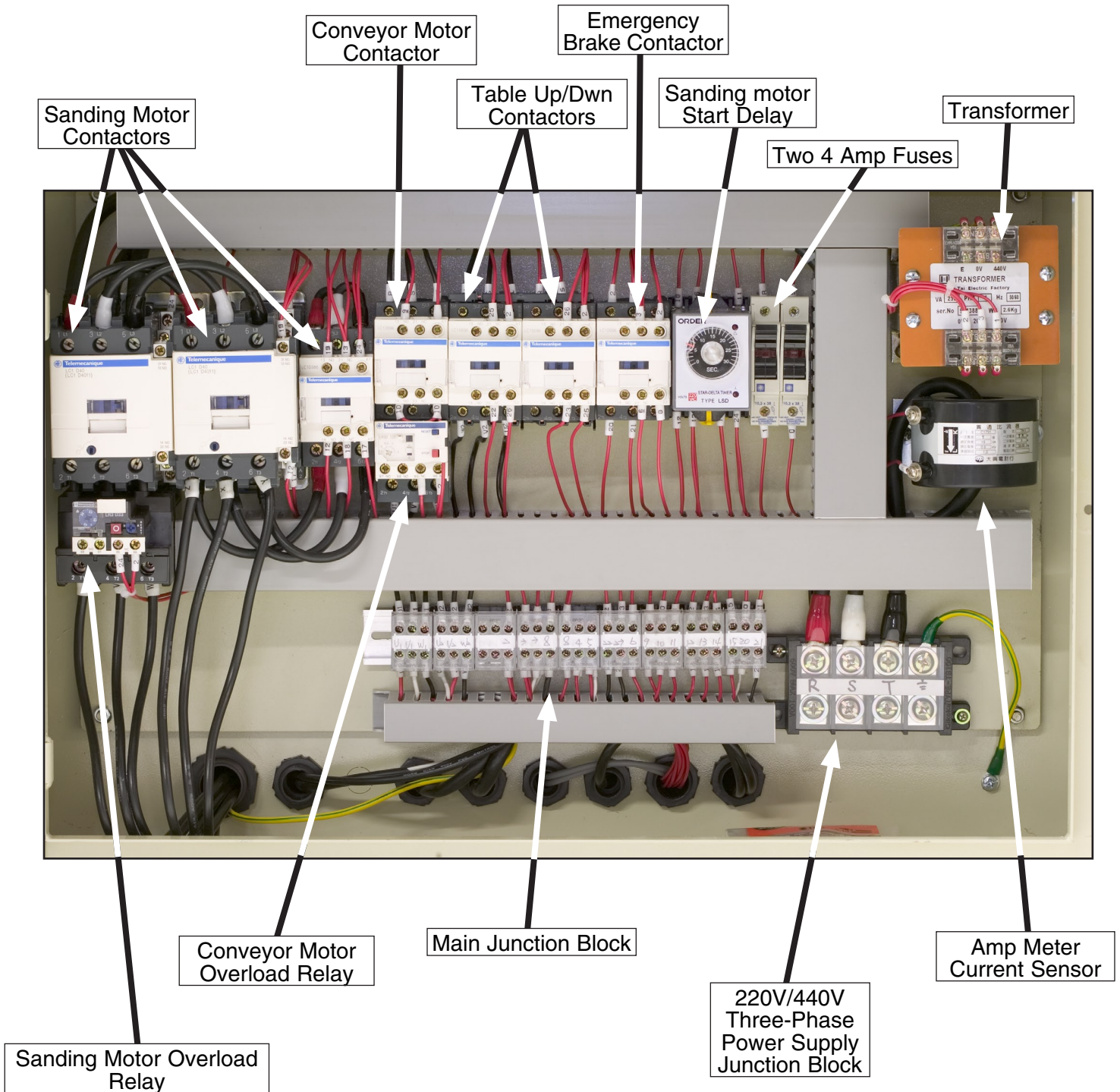

# General Electric Diagram (G0486/G0487)

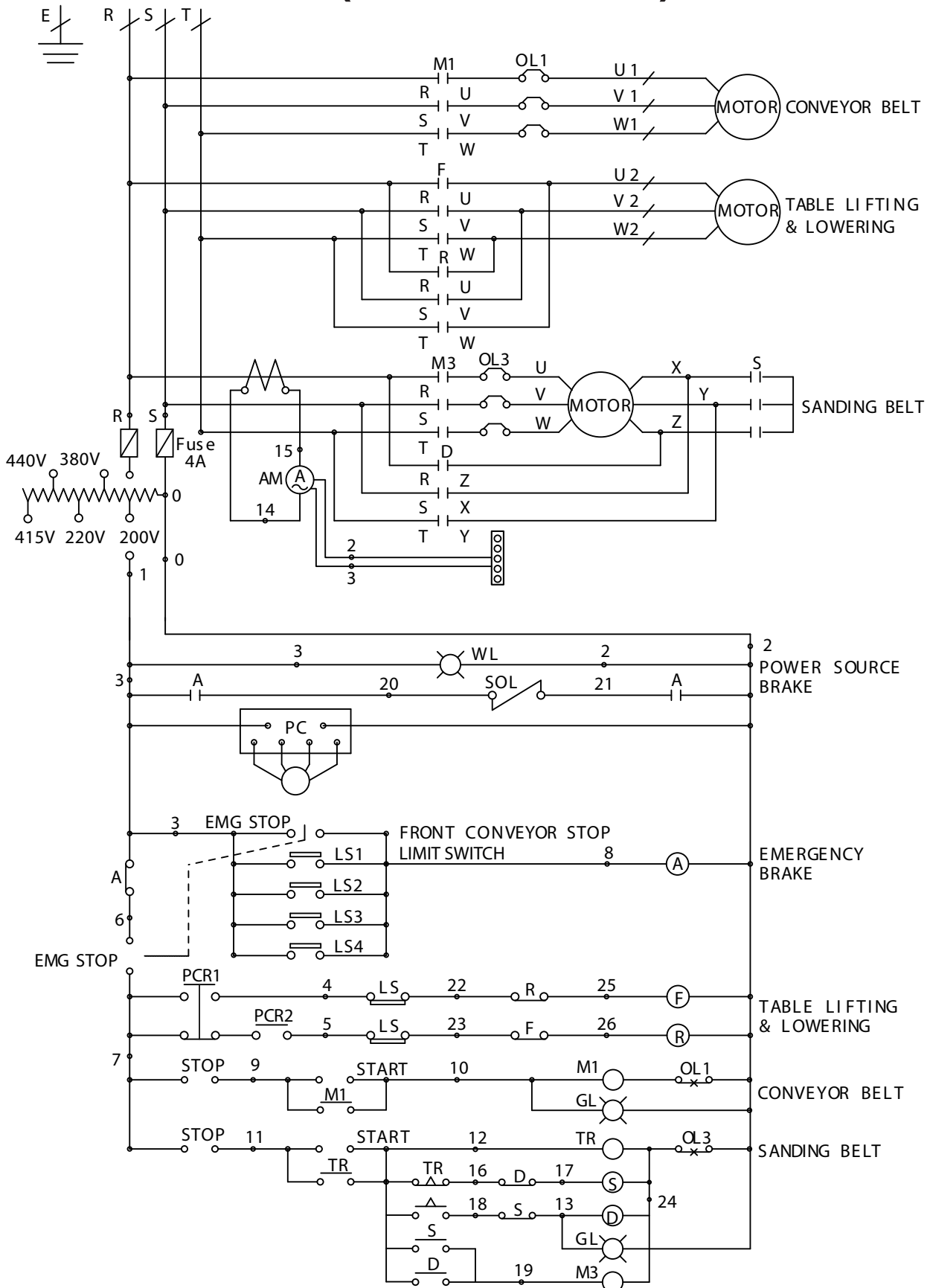

# Motor Wiring (G0486/G0487)

(STAR DELTA)

SANDING BELT MOTOR

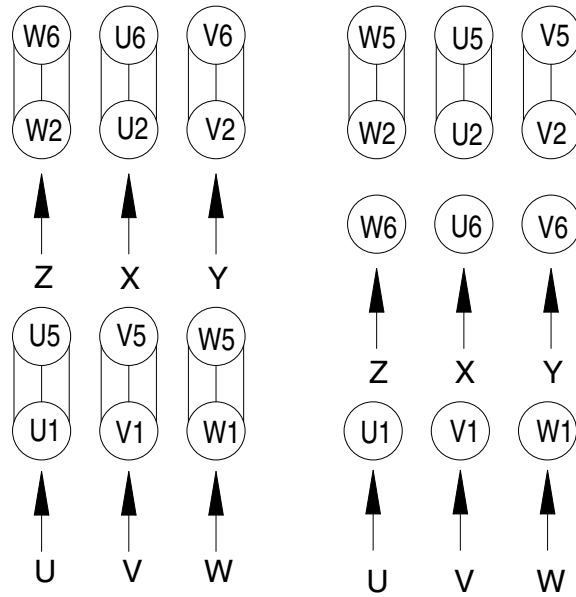

220V 3-Phase Connection

440V 3-Phase Connection

CONVEYOR BELT MOTOR

TABLE UP/DOWN MOTOR

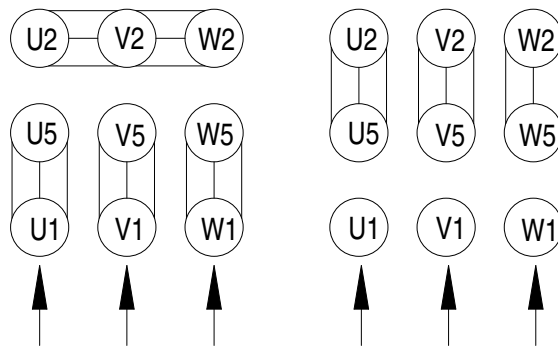

(CONVEYOR BELT)

U1 V1 W1

U1 V1 W1

(TABLE UP/DOWN)

U2 V2 W2

U2 V2 W2

220V 3-Phase Connection

440V 3-Phase Connection



# Tool Box and Accessories Diagram

## 0000 Series Parts

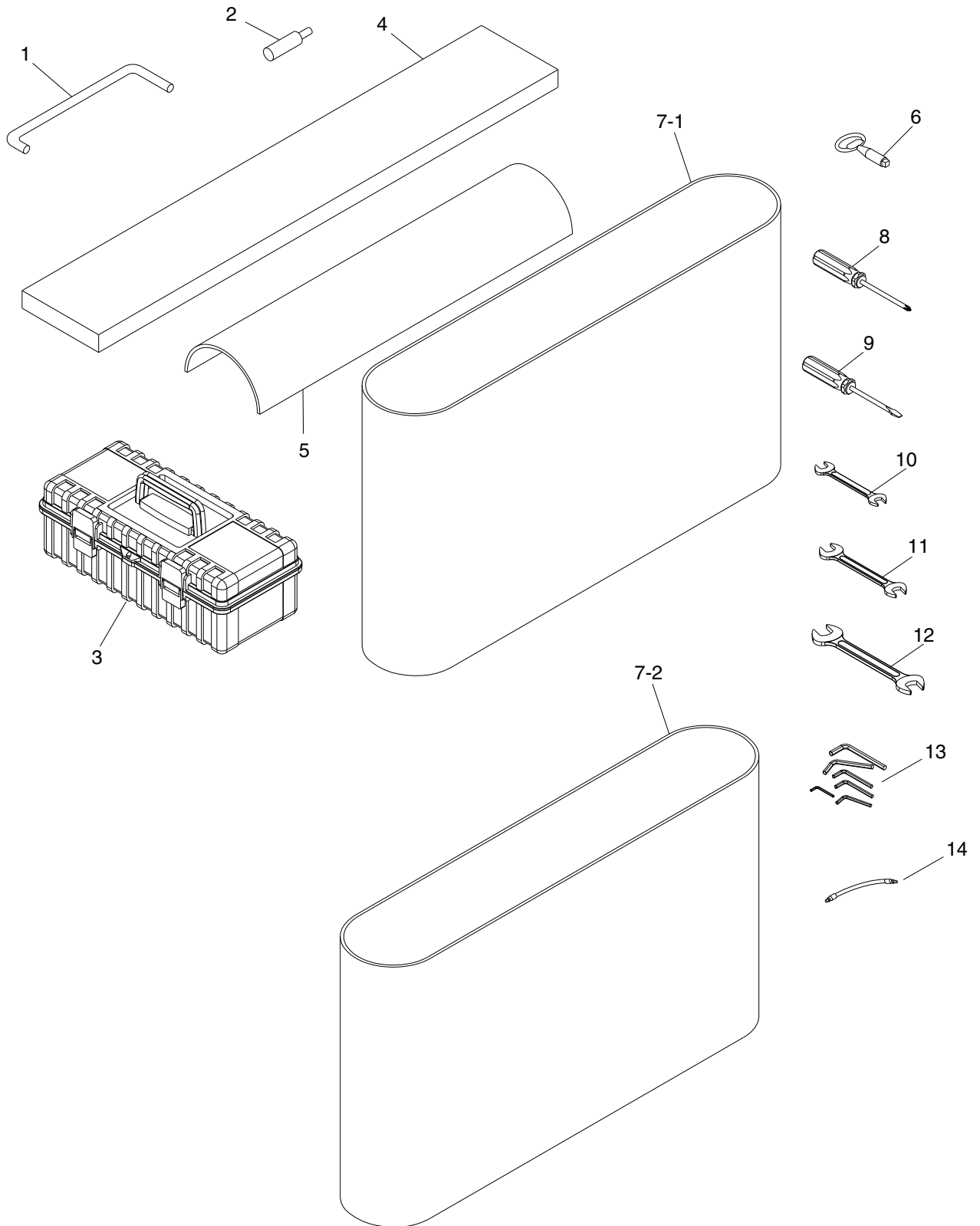

# Tool Box and Accessories Parts List

REF	PART #	DESCRIPTION
1	PH29330001	PLATEN REMOVAL TOOL
2	P9962Z0002	CERAMIC LIMIT SWITCH POST
3	PH29330003	TOOL BOX
4	P05810004	44" PLATEN FELT (G0486)
4	P04870004	52" PLATEN FELT (G0487)
5	P05810005	GRAPHITE 44" X 3.54" (G0486)
5	P04870005	GRAPHITE 52" X 3.54" (G0487)
6	PH29330006	DOOR HANDLE
7-1	P04860007-1	SANDPAPER #100 (43" X 75") G0486
7-1	P04870007-1	SANDPAPER #100 (51" X 75") G0487

REF	PART #	DESCRIPTION
7-2	P04860007-2	SANDING BELT #180 (43" X 75") G0486
7-2	P04870007-2	SANDING BELT #180 (51" X 75") G0487
8	P04860008	#2 PHILLIPS SCREWDRIVER
9	P04860009	#2 STANDARD SCREWDRIVER
10	PWR810	WRENCH 8 X 10
11	PWR1214	WRENCH 12 X 14
12	PWR1719	WRENCH 17 X 19
13	PH29330013	HEX WRENCH SET
14	P04860014	FLEXIBLE GREASE GUN EXTENSION



# Sanding Motor System Diagram

## 1000 Series Parts

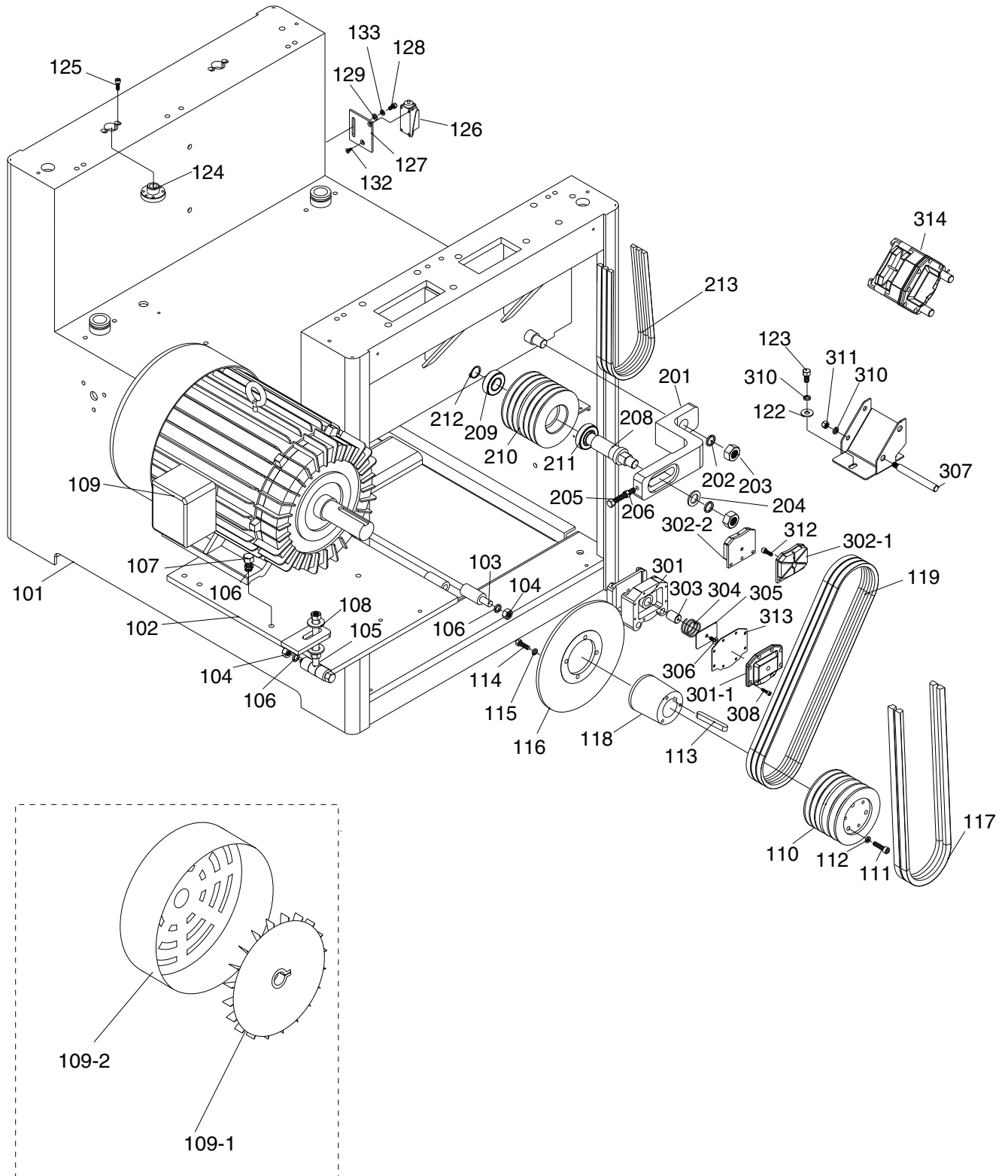

# Sanding Motor System Parts List

REF	PART #	DESCRIPTION
101	P05811101	MACHINE FRAME (G0486)
101	P04871101	MACHINE FRAME (G0487)
102	P05811102	MOTOR BASE (G0486)
102	P04871102	MOTOR BASE (G0487)
103	P05811103	MOTOR BASE HINGE
104	PN06	HEX NUT 1/2-12
105	PH29331105	MOTOR BASE ADJUSTMENT ROD
106	PLW07	LOCK WASHER 1/2
107	PB41	HEX BOLT 1/2-12 X 1-1/2
108	PW01	FLAT WASHER 1/2
109	P04861109	MOTOR 25 HP 220/440V 3PH (G0486)
109	P04871109	MOTOR 30HP 220/440V 3PH (G0487)
109-1	P04861109-1	MOTOR FAN (G0486)
109-1	P04871109-1	MOTOR FAN (G0487)
109-2	P04861109-2	MOTOR FAN COVER (G0486)
109-2	P04871109-2	MOTOR FAN COVER (G0487)
110	P05811110	PULLEY
111	PSB11	CAP SCREW 5/16-18 X 1-1/4
112	PLW01	LOCK WASHER 5/16
113	PH29331113	KEY 12 X 8 X 105
114	PB03	HEX BOLT 5/16 -18 X 1
115	PLW01	LOCK WASHER 5/16
116	PH29331116	ROTOR
117	PVB76	V-BELT B-76 5L760
118	P05811118	PULLEY BUSHING
119	PVA50	V-BELT A-50 4L500
121	P04861121	BRAKE BRACKET
122	PW02	FLAT WASHER 3/8
123	PB21	HEX BOLT 3/8-16 X 3/4
124	P04861124	FLAT HEAD NUT
125	PSB05	CAP SCREW 1/4-20 X 3/4
126	P04861126	LIMIT SWITCH

REF	PART #	DESCRIPTION
127	P04861127	LIMIT SWITCH PLATE
128	PB19	HEX BOLT 1/4-20 X 1/2
129	PW06	FLAT WASHER 1/4
132	PFH12M	FLAT HD SCR M6-1 X 25
133	PLW02	LOCK WASHER 1/4
201	P04861201	IDLE WHEEL ADJ. BRACKET
202	PLW10	LOCK WASHER 3/4
203	PN06	HEX NUT 1/2-12
204	PW13	FLAT WASHER 3/4
205	PB84	HEX BOLT 3/8-16 X 3-1/2
206	PN08	HEX NUT 3/8-16
208	P04861208	IDLE WHEEL SHAFT
209	P6305	BALL BEARING 6305ZZ
210	P04861210	PULLEY
211	P6206	BEARING 6206ZZ
212	PR11M	EXT RETAINING RING 25MM
213	PVA40	V-BELT A-40 4L400
301	P04861301	BRAKE BRACKET
301-1	P04861301-1	BRAKE BRACKET FRONT GUARD
302-1	P04861302-1	BRAKE LINING
302-2	P04861302-2	BRAKE LINING
303	P04861303	BRAKE ARBOR
304	P04861304	BRAKE COMPRESSION SPRING
305	P04861305	BRAKE INSIDE PIECE
306	PFH04	FLAT HD SCR 1/4-20 X 5/8
307	P04861307	BRAKE PIN
308	PSB31	CAP SCREW 10-24 X 5/8
310	PLW04	LOCK WASHER 3/8
311	PN08	HEX NUT 3/8-16
312	PSB01	CAP SCREW 1/4-20 X 5/8
313	P04861313	BRAKE GASKET
314	P04861314	BRAKE ASSEMBLY



# Table Lift System Diagram

## 2000 Series Parts

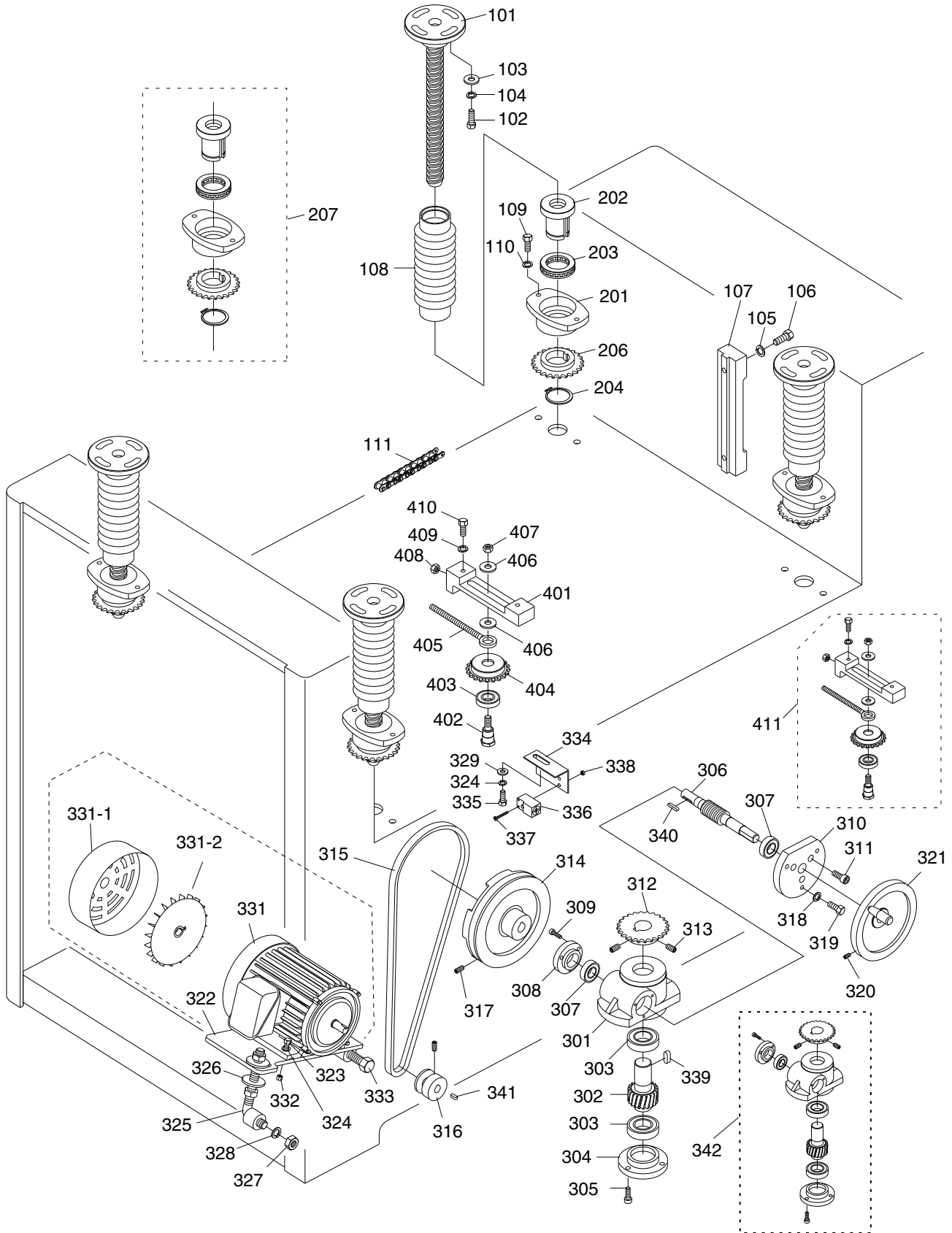

# Table Lift System Parts List

REF	PART #	DESCRIPTION
101	P04862101	ELEVATION SCREW
102	PB03	HEX BOLT 5/16-18 X 1
103	PW07	FLAT WASHER 5/16
104	PLW01	LOCK WASHER 5/16
105	PLW01	LOCK WASHER 5/16
106	PB18	HEX BOLT 3/8-16 X 1
107	P04862107	ELEVATION SLIDE
108	P04862108	DUST BOOT
109	PB07	HEX BOLT 5/16-18 X 3/4
110	PLW01	LOCK WASHER 5/16
111	P05812111	CHAIN (G0486)
111	P04872111	CHAIN (G0487)
201	P04862201	NUT HOUSING
202	P04862202	NUT
203	P51107	THRUST BEARING 51107
204	PR12M	EXT RETAINING RING 35MM
206	P04862206	SPROCKET WHEEL
207	P04862207	NUT HOUSING ASSEMBLY
301	P04862301	ELEVATION GEAR BOX
302	P04862302	WORM GEAR
303	P6005	BALL BEARING 6005ZZ
304	P04862304	BEARING CAP
305	PSB05	CAP SCREW 1/4-20 X 3/4
306	P04862306	WORM SHAFT
307	P6002	BALL BEARING 6002ZZ
308	P04862308	BEARING CAP
309	PSB33	CAP SCREW 10-24 X 3/4
310	P04862310	BEARING CAP
311	PSB01	CAP SCREW 1/4-20 X 5/8
312	P04862312	SPROCKET WHEEL
313	PSS08	SET SCREW 5/16-18 X 1/2
314	P04862314	PULLEY
315	PVA36	V-BELT A-36 4L360
316	P04862316	PULLEY
317	PSS07	SET SCREW 1/4-20 X 1/2
318	PLW01	LOCK WASHER 5/16

REF	PART #	DESCRIPTION
319	PB07	HEX BOLT 5/16-18 X 3/4
320	PSS07	SET SCREW 1/4-20 X 1/2
321	P04862321	HAND WHEEL
322	P04862322	MOTOR BASE
323	PB31	HEX BOLT 1/4-20 X 1
324	PLW02	LOCK WASHER 1/4
325	P04862325	MOTOR BASE ADJ. ROD
326	PW01	FLAT WASHER 1/2
327	PN06	HEX NUT 1/2-12
328	PLW07	LOCK WASHER 1/2
329	PW06	FLAT WASHER 1/4
331	PH29332331	MOTOR 1/4HP 220V/440V 3PH
331-1	PH29332331-1	MOTOR FAN COVER
331-2	PH29332331-2	MOTOR FAN
332	PN05	HEX NUT 1/4-20
333	PB89	HEX BOLT 1/2-12 X 4-1/2
334	P04862334	PROXIMITY SWITCH PLATE
335	PB19	HEX BOLT 1/4-20 X 1/2
336	P04862336	PROXIMITY SWITCH
337	P04862337	SPECIAL SCREW M3-.5 X 35
338	PN07M	HEX NUT M3-.5
339	PK14	KEY 5/16 X 5/16 X 3/4
340	PK48M	KEY 4 X 4 X 20
341	PK37M	KEY 4 X 4 X 16
342	P04862342	ELEVATION GEAR BOX ASSY
401	P04862401	SPROCKET WHEEL ADJUSTOR
402	P04862402	SPROCKET WHEEL SHAFT
403	P6003	BALL BEARING 6003ZZ
404	P04862404	ADJUSTMENT SPROCKET
405	P04862405	SPROCKET ADJUSTMENT ROD
406	PW02	FLAT WASHER 3/8
407	PN08	HEX NUT 3/8-16
408	PN02	HEX NUT 5/16-18
409	PLW01	LOCK WASHER 5/16
410	PB07	HEX BOLT 5/16-18 X 3/4
411	P04862411	SPROCKET ASSEMBLY



# Conveyor System Diagram

## 3000 Series Parts

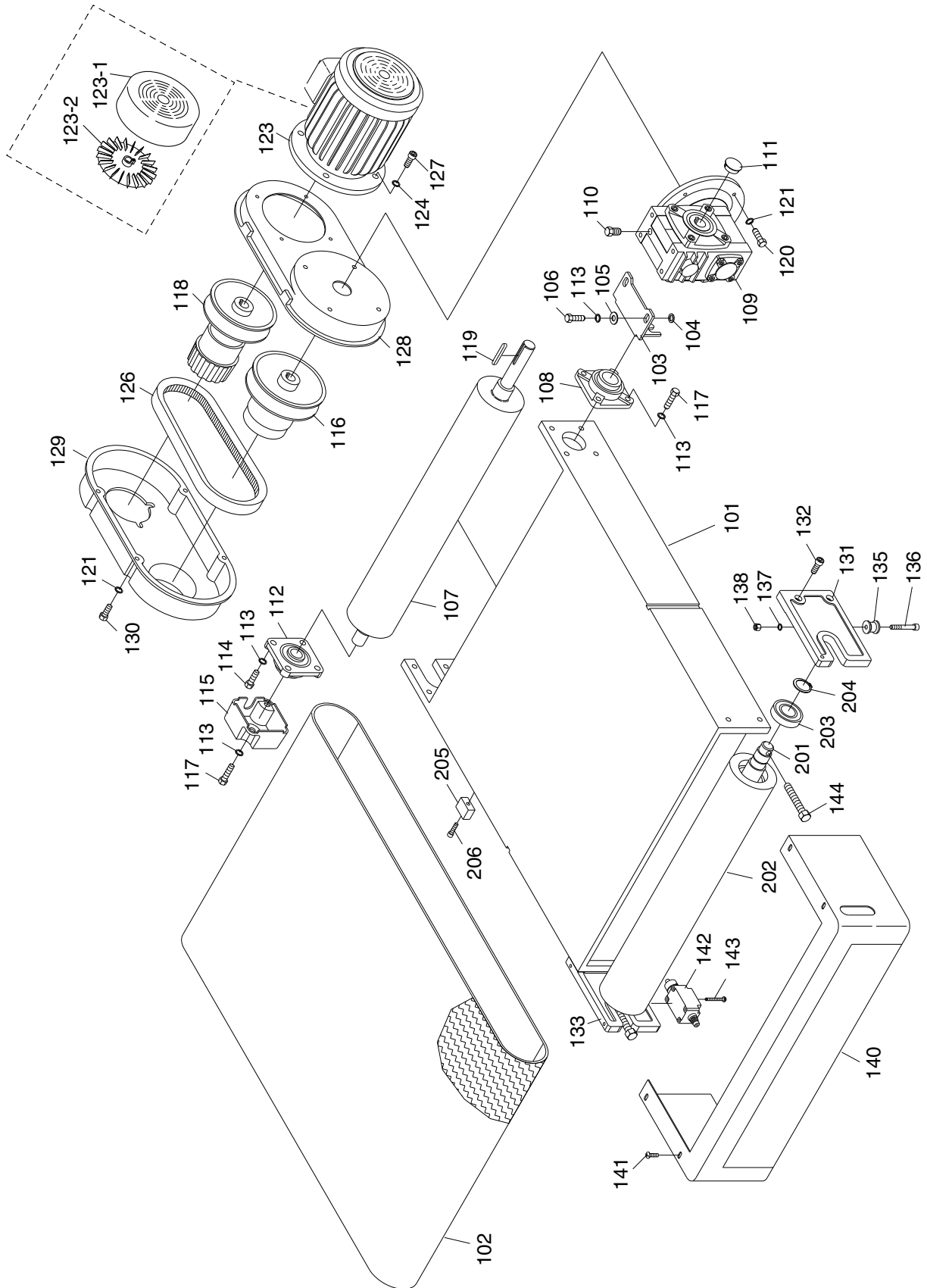

# Conveyor System Parts List

REF	PART #	DESCRIPTION
101	P05813101	CONVEYOR TABLE (G0486)
101	P04873101	CONVEYOR TABLE (G0487)
102	P05813102	CONVEYOR BELT (G0486)
102	P04873102	CONVEYOR BELT (G0487)
103	P04863103	REDUCER FIX PLATE
104	P04863104	CUSHION
105	PLW04	LOCK WASHER 3/8
106	PB18	HEX BOLT 3/8-16 X 1
107	P05813107	OUTFEED ROLLER (G0486)
107	P04873107	OUTFEED ROLLER (G0487)
108	PH29343108	BEARING UCF206
109	P04863109	GEARBOX
110	P04863110	PLUG
111	P04863111	PLUG
112	P0539326	BEARING UCF205
113	PLW04	LOCK WASHER 3/8
114	PB24	HEX BOLT 3/8-16 X 1-1/4
115	P04863115	BEARING CAP
116	P04863116	DRIVEN PULLEY
117	PB16	HEX BOLT 3/8-16 X 1-1/2
118	P04863118	DRIVING PULLEY
119	PK66M	KEY 7 X 7 X 55
120	PB07M	HEX BOLT M8-1.25 X 25
121	PLW04M	LOCK WASHER 8MM
123	P05813123	MOTOR 2HP 220/440V 3PH
123-1	P05813123-1	MOTOR FAN COVER
123-2	P05813123-2	MOTOR FAN

REF	PART #	DESCRIPTION
124	PLW06M	LOCK WASHER 10MM
126	P04863126	TIMING BELT 1422V-290
127	PSB64M	CAP SCREW M10-1.5 X 25
128	P04863128	VARIABLE SPEED UNIT BASE PLATE
129	P04863129	VARIABLE SPEED UNIT COVER
130	PB09M	HEX BOLT M8-1.25 X 20
131	P04863131	INFEED ROLLER BRACKET
132	PSB16	CAP SCREW 3/8-16 X 3/4
133	P04863133	INFEED ROLLER BRACKET
135	P04863135	CONVEYOR BLT POSITIONING WHEEL
136	PSB70	CAP SCREW 5/16-18 X 2
137	PLW01	LOCK WASHER 5/16
138	PN02	HEX NUT 5/16-18
140	P05813140	EMGNCY BRAKE PUSH-PLATE (G0486)
140	P04873140	EMGNCY BRAKE PUSH-PLATE (G0487)
141	PS04	PHLP HD SCR 1/4-20 X 1/2
142	P04863142	LIMIT SWITCH
143	PS10	PHLP HD SCR 10-24 X 1-1/2
144	PB95	HEX BOLT 1/2-12 X 3
201	P05813201	INFEED ROLLER SHAFT (G0486)
201	P04873201	INFEED ROLLER SHAFT (G0487)
202	P05813202	INFEED ROLLER (G0486)
202	P04873202	INFEED ROLLER (G0487)
203	P6206	BALL BEARING 6206ZZ
204	PR15M	EXT RETAINING RING 30MM
205	P04863205	ELEVATION LIMITER
206	PSB62	CAP SCREW 1/4-20 X 1-1/2



# Feed, Drum, and Pressure Roller Diagram

## 4000 Series Parts

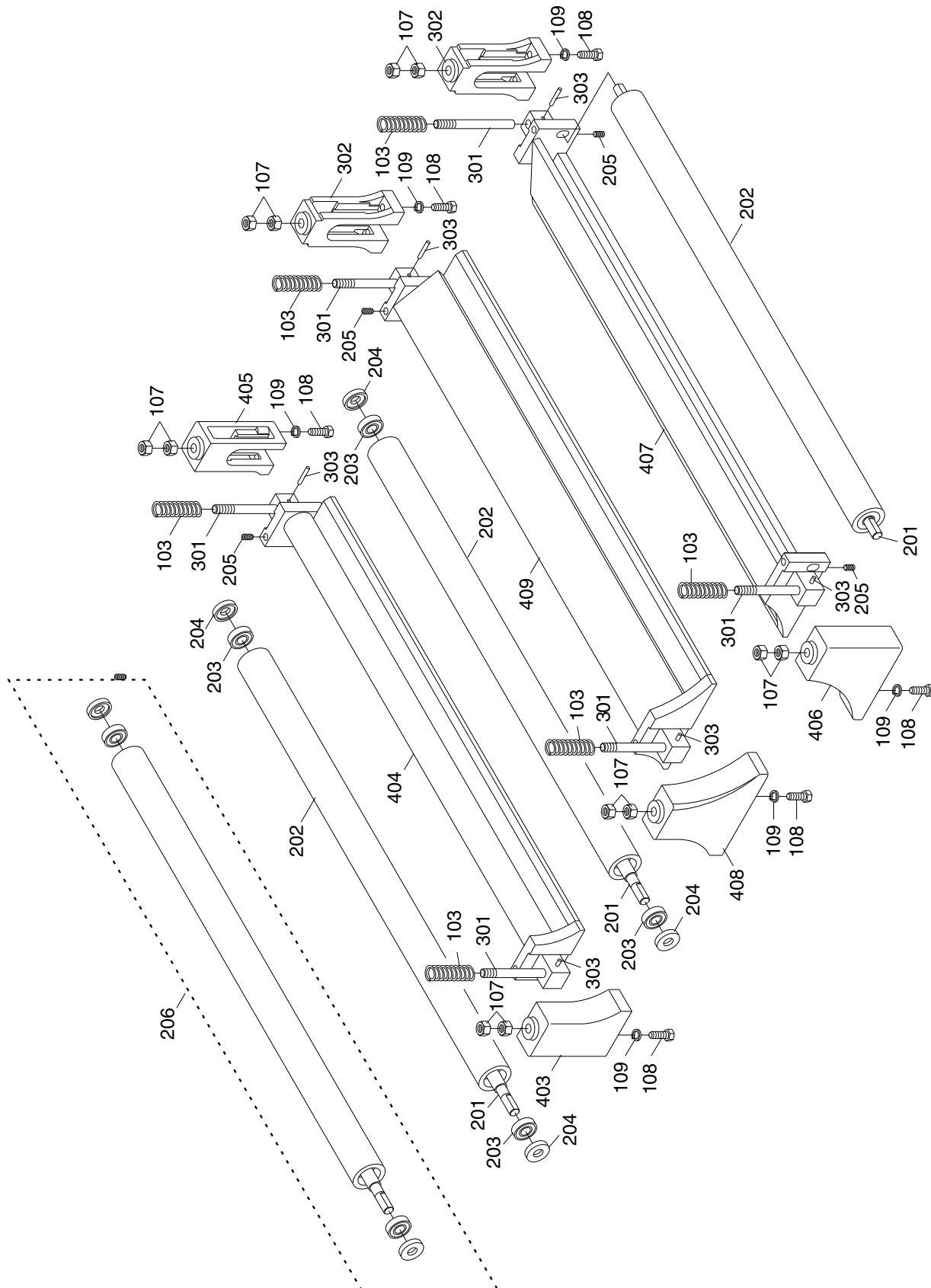

# Feed, Drum, and Pressure Roller Parts List

REF	PART #	DESCRIPTION
103	P04864103	COMPRESSION SPRING
107	PN08	HEX NUT 3/8-16
108	PB12	HEX BOLT 5/16-18 X 1-1/4
109	PLW01	LOCK WASHER 5/16
201	P05814201	PISTON ROLLER SHAFT (G0486)
201	P04874201	PISTON ROLLER SHAFT (G0487)
202	P05814202	PISTON ROLLER (G0486)
202	P04874202	PISTON ROLLER (G0487)
203	P6001	BALL BEARING 6001ZZ
204	P04864204	SHAFT BEARING COLLAR
205	PSS07	SET SCREW 1/4-20 X 1/2
206	P04864206	PISTON ROLLER ASSEMBLY
301	PH29334301	ADJUSTMENT KNOB

REF	PART #	DESCRIPTION
302	P04864302	MIDDLE PISTON BRACKET
303	PRP16M	ROLL PIN 3 X 24MM
403	P04864403	LR PISTON BRACKET
404	P04864404	REAR DEFLECTOR (G0486)
404	P04874404	REAR DEFLECTOR (G0487)
405	P04864405	RR PISTON BRACKET
406	P04864406	LF PISTON BRACKET
407	P04864407	FRONT DEFLECTOR (G0486)
407	P04874407	FRONT DEFLECTOR (G0487)
408	P04864408	L MIDDLE PISTON BRACKET
409	P04864409	MIDDLE DEFLECTOR (G0486)
409	P04874409	MIDDLE DEFLECTOR (G0487)





# Sanding Drum and Platen Parts List

REF	PART #	DESCRIPTION
101	P04865101	BEARING HOUSING
102	P05815102	RUBBER ROLLER (G0486)
102	P04875102	RUBBER ROLLER (G0487)
103	P04865103	FASTENING TUBE
104	P05275104	CYL. CARTRIDGE BEARING UCC206
105	P04865105	PULLEY
106	PSB11	CAP SCREW 5/16-18 X 1-1/4
107	PK11	KEY 5/16 X 5/16 X 1-3/16
108	PLW01	LOCK WASHER 5/16
109	P6205	BALL BEARING 6205ZZ
110	PLW07	LOCK WASHER 1/2
111	PSB76	CAP SCREW 1/2-12 X 1-1/2
112	PSB04	CAP SCREW 1/4-20 X 1/2
113	P04865113	BEARING CAP
114	P04865114	GREASE FITTING W/CAP
115	P04865115	GREASE FITTING W/CAP
116	P04865116	PLUG
117	P04865117	PULLEY COVER
118	PS04	PHLP HD SCR 1/4-20 X 1/2
119	P04865119	SPANNER NUT
201	P04865201	BEARING HOUSING
202	P05815202	STEEL ROLLER (G0486)
202	P04875202	STEEL ROLLER (G0487)
203	P04865203	SPECIAL CAP SCREW M6-.75 X 6
204	P05275104	CYL. CARTRIDGE BEARING UCC205
205	P04865205	HANDLE
206	P04865206	SPECIAL SCREW
211	P04865211	BEARING BRACKET PAD
301	P05815301	44" GRAPHITE BRACKET MALE (G0486)
301	P04875301	52" GRAPHITE BRACKET MALE (G0487)
302	P05815302	44" GRAPHITE BRACKET FML (G0486)
302	P04875302	52" GRAPHITE BRACKET FML (G0487)
303	P05810004	44" FELT PLATEN PAD (G0486)
303	P04875303	52" FELT PLATEN PAD (G0487)
304	P05810005	GRAPHITE 44" X 3.54" (G0486)
304	P04875304	GRAPHITE 52" X 3.54" (G0487)

REF	PART #	DESCRIPTION
305	PS01	PHLP HD SCR 10-24 X 1/2
306	P05815306	GRAPHITE PRESSURE PLATE (G0486)
306	P04875306	GRAPHITE PRESSURE PLATE (G0487)
307	P04865307	GRAPHITE BRACKET BASE
308	P04865308	GRAPHITE BRACKET SHAFT (G0486)
308	P04875308	GRAPHITE BRACKET SHAFT (G0487)
309	P04865309	LOCK COLLAR
310	PSS03	SET SCREW 1/4-20 X 3/8
311	PK110	KEY 1/4 X 1/4 X 1
312	P04865312	COMPRESSION SPRING
313	P04865313	HOUSING
314	P04865314	GRAPHITE BRACKET SHAFT
315	PSB16	CAP SCREW 3/8-16 X 3/4
316	PW02	FLAT WASHER 3/8
317	PW02	FLAT WASHER 3/8
318	P04865318	HANDLE
319	PSS08	SET SCREW 5/16-18 X 1/2
320	P04865320	ADJUSTMENT RING
321	PB03	HEX BOLT 5/16-18 X 1
322	PW07	FLAT WASHER 5/16
323	P04865323	HANDLE
325	P04865325	GRAPHITE BRACKET ADJ. ASSEMBLY
401	P04865401	BEARING HOUSING
402	P05815402	RUBBER ROLLER (G0486)
402	P04875402	RUBBER ROLLER (G0487)
403	P04865403	FASTENING TUBE
404	P05275104	CYL. CARTRIDGE BEARING UCC206
405	P04865405	PULLEY
406	PSB11	CAP SCREW 5/16-18 X 1-1/4
407	P04865407	BEARING HOUSING
408	P04865408	BEARING BRACKET PAD
409	P6206	BEARING 6206ZZ
410	P04865410	SPANNER NUT
411	P04865411	BEARING CAP
417	P04865417	PULLEY COVER



# Upper Roller System Diagram

## 6000 Series Parts

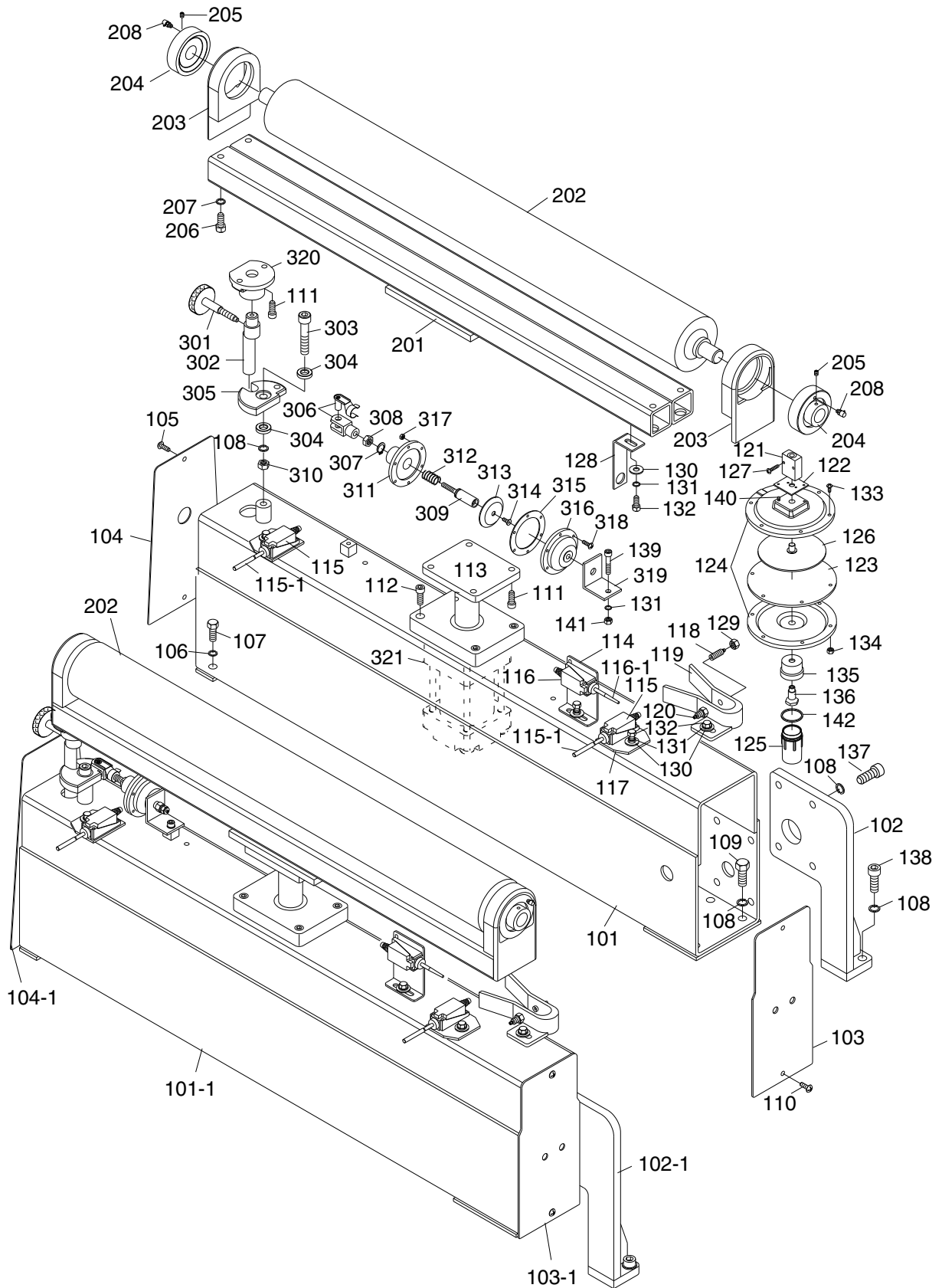

# Upper Roller System Parts List

REF	PART #	DESCRIPTION
101	P04866101	SQUARE FRAME REAR (G0486)
101	P04876101	SQUARE FRAME REAR (G0487)
101-1	P04866101-1	SQUARE FRAME FRONT (G0486)
101-1	P04876101-1	SQUARE FRAME FRONT (G0487)
102	P04866102	REAR BRACKET (G0486)
102	P04876102	REAR BRACKET (G0487)
102-1	P04866102-1	FRONT BRACKET (G0486)
102-1	P04876102-1	FRONT BRACKET (G0487)
103	P04866103	FRAME SEAL RIGHT (G0486)
103	P04876103	FRAME SEAL RIGHT (G0487)
103-1	P04866103-1	FRAME SEAL FRNT RIGHT (G0486)
103-1	P04876103-1	FRAME SEAL FRNT RIGHT (G0487)
104	P04866104	FRAME SEAL LEFT (G0486)
104	P04876104	FRAME SEAL LEFT (G0487)
104-1	P04866104-1	FRAME SEAL FRNT LEFT (G0486)
104-1	P04876104-1	FRAME SEAL FRNT LEFT (G0487)
105	PFH03	FLAT HD SCR 1/4-20 X 1/2
106	PLW04	LOCK WASHER 3/8
107	PB18	HEX BOLT 3/8-16 X 1
108	PLW07	LOCK WASHER 1/2
109	PB40	HEX BOLT 1/2-12 X 1-1/4
110	PS04	PHLP HD SCR 1/4-20 X 1/2
111	PSB07	CAP SCREW 5/16-18 X 3/4
112	PB03	HEX BOLT 5/16-18 X 1
113	P04866113	AIR CYLINDER
114	P04866114	LIMIT SWITCH HOLDER L-TYPE
115	P04866115	LIMIT SWITCH W/CERAMIC TIP
115-1	P04866115-1	CERAMIC TIP
116	P04866116	LIMIT SWITCH W/PLASTIC TIP
116-1	P04866116-1	PLASTIC TIP
117	P04866117	LIMIT SWITCH HOLDER
118	P04866118	AIR SENSOR NOZZLE FEMALE
119	P04866119	AIR FORK
120	P04866120	AIR SENSOR NOZZLE MALE
121	P04866121	THROTTLE VALVE
122	P04866122	THROTTLE VALVE BASE
123	P04866123	DIAPHRAGM
124	P04866124	HOUSING ASSEMBLY
125	P04866125	OIL CAP
126	P04866126	ALUMINUM PLATE
127	PS02M	PHLP HD SCR M4-.7 X 12
128	P04866128	SHUTDOWN BRACKET
129	PN11	HEX NUT 3/8-24
130	PW07	FLAT WASHER 5/16

REF	PART #	DESCRIPTION
131	PLW01	LOCK WASHER 5/16
132	PB09	HEX BOLT 5/16-18 X 1/2
133	PS08	PHLP HD SCR 10-24 X 3/4
134	PN07	HEX NUT 10-24
135	P04866135	CONNECTOR OF OIL CAP
136	P04866136	SHAFT OF OIL CAP
137	PSB76	CAP SCREW 1/2-12 X 1-1/2
138	PB53	HEX BOLT 1/2-12 X 1
139	PSB08	CAP SCREW 5/16-18 X 1-1/2
140	PFH25M	FLAT HD SCR M4-.7 X 12
141	PN02	HEX NUT 5/16-18
142	P04866142	O-RING
201	P04866201	UPPER ROLLER BRACKET (G0486)
201	P04876201	UPPER ROLLER BRACKET (G0487)
202	P05816202	UPPER ROLLER (G0486)
202	P04876202	UPPER ROLLER (G0487)
203	P04866203	UPPER ROLLER BRACKET
204	P05275104	CYL. CARTRIDGE BEARING UCC205
205	PSS02M	SET SCREW M6-1 X 6
206	PSB16	CAP SCREW 3/8-16 X 3/4
207	PLW04	LOCK WASHER 3/8
208	P04866208	GREASE FITTING W/DUST CAP
301	P05816301	TRIMMING SCREW 2 X 90MM (G0486)
301	P04876301	TRIMMING SCREW 2 X 90MM (G0487)
302	P04866302	ECCENTRIC ROD
303	PBS98	CAP SCREW 1/2-12 X 2-3/4
304	PW01	FLAT WASHER 1/2
305	P04866305	ECCENTRIC
306	P04866306	CLEVIS ASSEMBLY
307	PR05M	EXT RETAINING RING 15MM
308	PN02M	HEX NUT M10-1.5
309	P04866309	SHAFT OF AIR CYLINDER
310	PN06	HEX NUT 1/2-12
311	P04866311	BOTTOM COVER
312	P04866312	COMPRESSION SPRING
313	P04866313	ALUMINUM PLATE
314	PFH02M	FLAT HD SCR M6-1 X 12
315	P04866315	DIAPHRAGM
316	P04866316	TOP COVER
317	PN07	HEX NUT 10-24
318	PS08	PHLP HD SCR 10-24 X 3/4
319	P04866319	AIR CYLINDER BASE
320	P04866320	ECCENTRIC SHAFT FRAME
321	P04866321	AIR CYLINDER ASSEMBLY



# Cabinet Assembly Diagram

## 7000 Series Parts

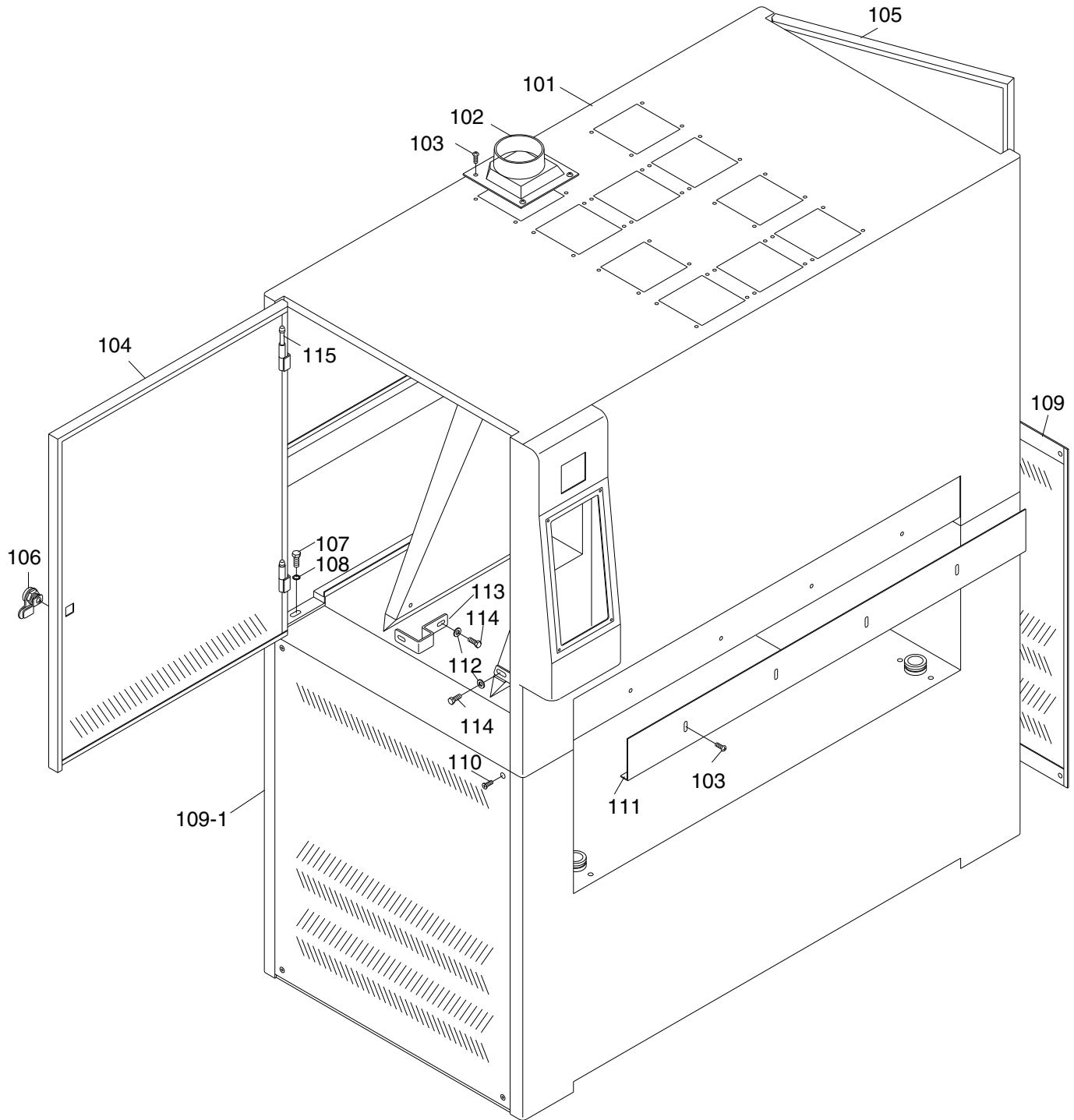

# Cabinet Assembly Parts List

REF	PART #	DESCRIPTION
101	P04867101	UPPER FRAME COVER (G0486)
101	P04877101	UPPER FRAME COVER (G0487)
102	P04867102	DUST PORT 4"
103	PS14M	PHLP HD SCR M6-1 X 12
104	P04867104	LEFT ACCESS PANEL
105	P04867105	RIGHT ACCESS PANEL
106	P04867106	DOOR LOCK
107	PB07	HEX BOLT 5/16-18 X 3/4
108	PW07	FLAT WASHER 5/16

REF	PART #	DESCRIPTION
109	P05817109	RIGHT DOOR, LOWER FRAME
109-1	P05817109-1	LEFT DOOR, LOWER FRAME
110	PFH03	FLAT HD SCR 1/4-20 X 1/2
111	P05817111	FRONT PROTECTION PLATE (G0486)
111	P04877111	FRONT PROTECTION PLATE (G0487)
112	PW06	FLAT WASHER 1/4
113	P04867113	FIXING PLATE
114	PB02M	HEX BOLT M6-1 X 12
115	P04867115	HINGE BOLT



# Main Electrical Panel and Controls Diagram

## 8000 Series Parts

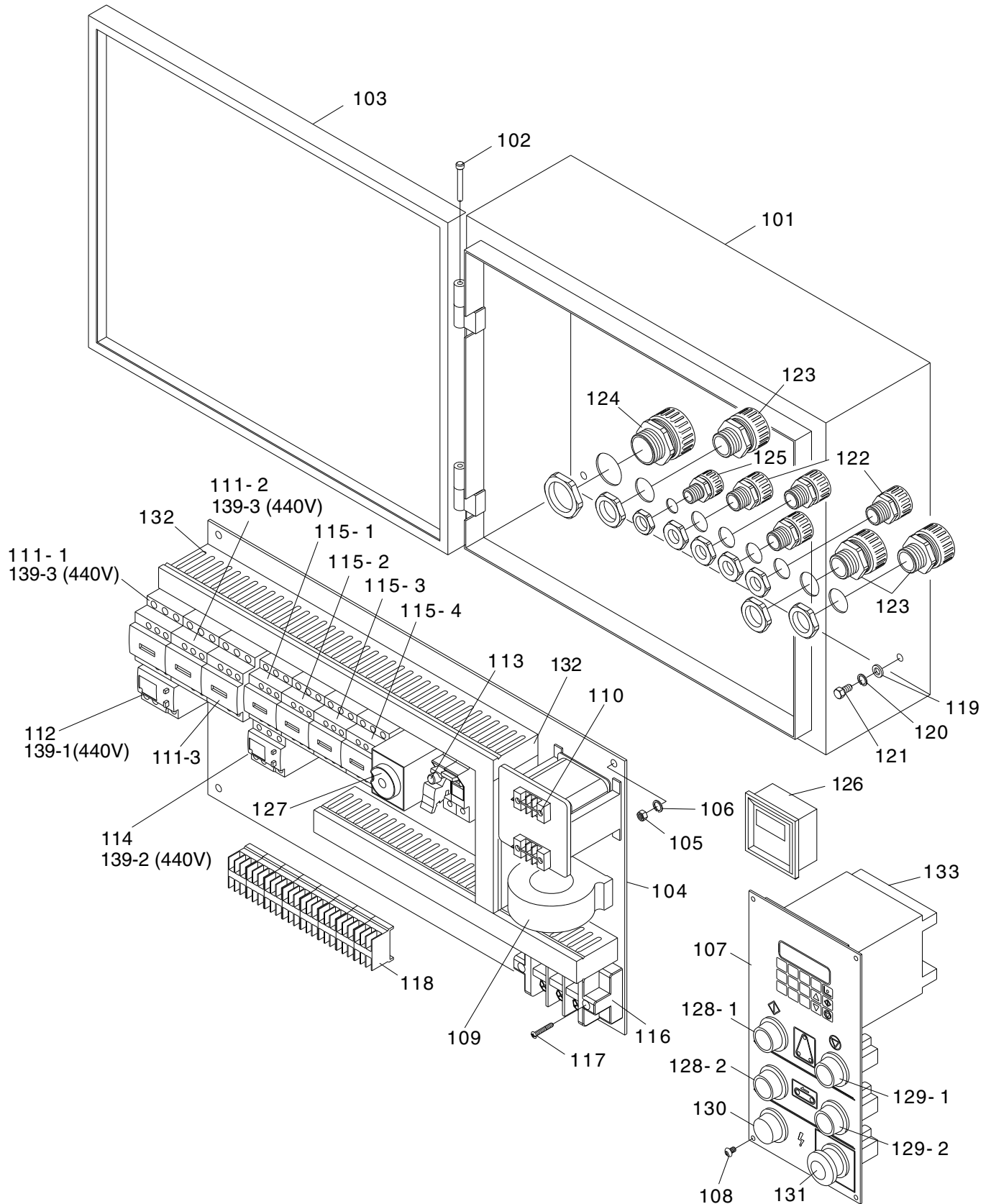

# Main Electrical Panel and Controls Parts List

REF	PART #	DESCRIPTION
101	P04868101	ELECTRICAL CONTROL BOX (G0486)
101	P04878101	ELECTRICAL CONTROL BOX (G0487)
102	P04868102	HINGE BOLT
103	P04868103	ELECTRICAL CTRL BOX DOOR (G0486)
103	P04878103	ELECTRICAL CTRL BOX DOOR (G0487)
104	P04868104	BASE PLATE (G0486)
104	P04878104	BASE PLATE (G0487)
105	PN05	HEX NUT 1/4-20
106	PLW02	LOCK WASHER 1/4
107	P04868107	CONTROL PANEL
108	PS07M	PHLP HD SCR M4-.7 X 8
109	P04868109	CURRENT SENSOR
110	P04868110	TRANSFORMER
111-1	P04868111-1	CONTACTOR LC1-D386 (G0486)
111-1	P04878111-1	CONTACTOR LC1-D40 (G0487)
111-2	P04868111-2	CONTACTOR LC1-D386 (G0486)
111-2	P04878111-2	CONTACTOR LC1-D40 (G0487)
111-3	P04868111-3	CONTACTOR LC1-D326 (G0486)
111-3	P99798111-3	CONTACTOR LC1-D386 (G0487)
112	P04868112	RELAY LR3D-356 220V (30-38A) (G0486)
112	P04878112	RELAY LR3D-3355 220V (30-40A) (G0487)
113	P04868113	FUSE TE10.3 X 38 & 500V/4A
114	P05818114	RELAY LR3D-126 220V (5.5-8A)
115-1	PH29338115	CONTACTOR LC1-D096
115-2	P04868115-2	CONTACTOR LC1-096 (WITH LOCK)

## G0486 440V CONVERSION KIT

139	P04868139	440V CONVERSION KIT(G0486)
139-1	PH29348134	THERMAL RELAY LR3D-216 440V (12-18A) (G0486)
139-2	P99809139A	THERMAL RELAY LR3D-086 440V (2.5-4A) (G0486)

REF	PART #	DESCRIPTION
115-3	P04868115-3	CONTACTOR LC1-096 (WITH LOCK)
115-4	PH29338115	CONTACTOR LC1-D096
116	P05818116	POWER WIRE TERMINAL
117	PS51M	PHLP HD SCR M4-.7 X 30
118	P04868118	TERMINAL PLATE
119	PW06	FLAT WASHER 1/4
120	PLW02	LOCK WASHER 1/4
121	PB19	HEX BOLT 1/4-20 X 1/2
122	P04868122	PU CONNECTOR 1/2"
123	P04868123	PU CONNECTOR 3/4"
124	P04868124	CABLE CONNECTOR 1"
126	PH29338126A	DIGITAL AMP METER N/S (G0486, G0487)
127	P04868127	START DELAY LSD (STAR-DELTA) (G0486)
127	P04878127	START DELAY LSD (STAR-DELTA) (G0487)
128-1	PH29338128-1	SANDING BELT START SWITCH
128-2	PH29338128-2	CONVEYOR BELT START SWITCH
129-1	PH29338129-1	SANDING BELT STOP SWITCH
129-2	PH29338129-2	CONVYR BELT STOP SWITCH
130	PH29338130	POWER INDICATION LIGHT
131	PH29338131	EMERGENCY STOP SWITCH
132	PH29338132	WIRE COLUMN
133	PH29338133	COMPUTER

## G0487 440V CONVERSION KIT

139	P04878139	440V CONVERSION KIT(G0487)
139-1	P99809139A-1	THERMAL RELAY LR3D-226 440V(16-24A) (G0487)
139-2	P99809139A-3	THERMAL RELAY LR3D-086 440V (2.5-4A) (G0487)
139-3	P04878139-3	CONTACTOR SET LC1-D386 440V (G0487)



# Air System Diagram

## 9000 Series Parts

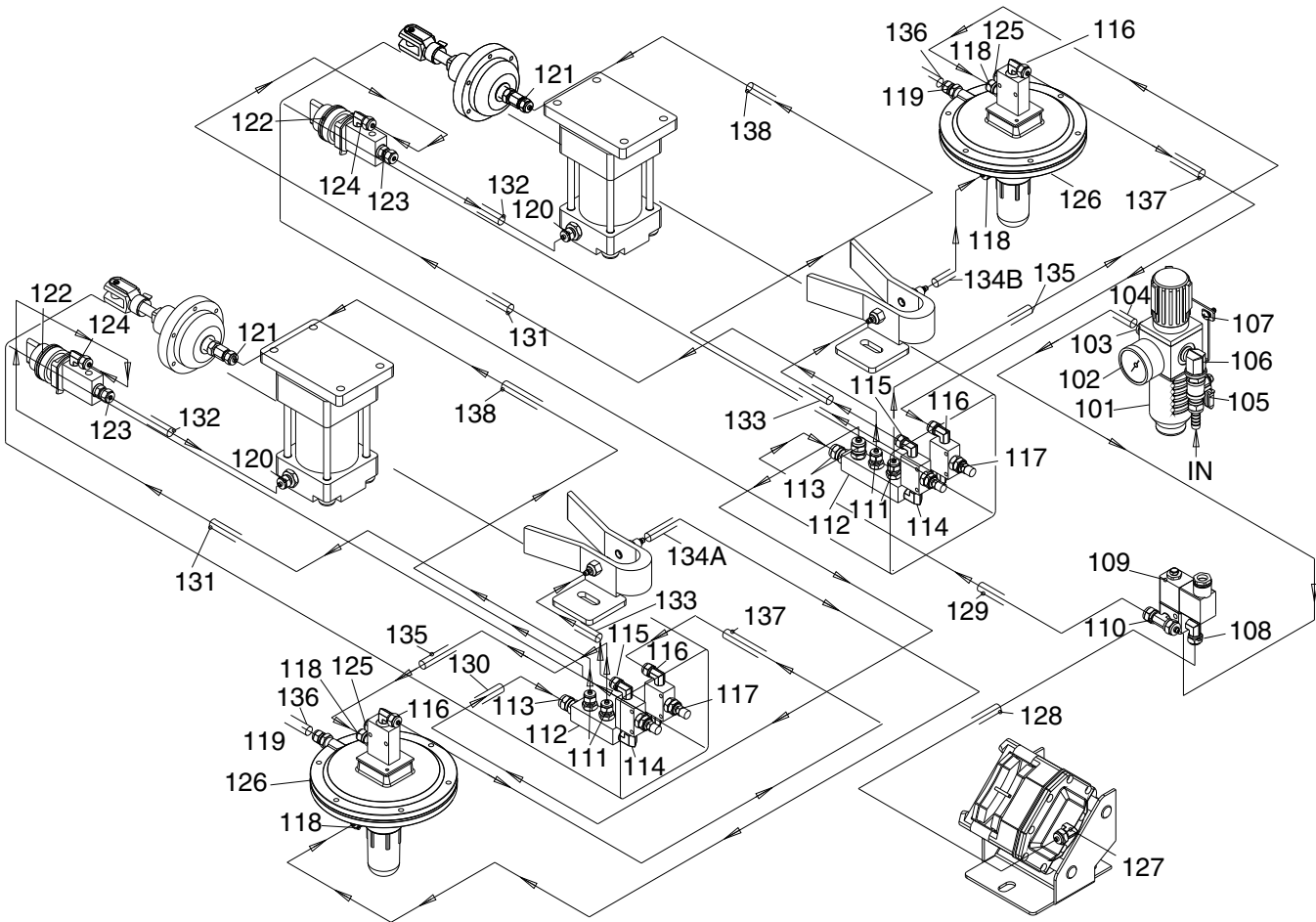

# Air System Parts List

REF	PART #	DESCRIPTION
101	PH29339101	FILTER CUP
102	PH29339102	PRESSURE REGULATOR W/GAUGE
103	PH29339103	BRONZE CONNECTOR 5/16N X 1/4T
104	PH29339104	8 X 900MM FLEXIBLE HOSE
105	PH29339105	AIR VALVE 1/4"
106	PH29339106	ELBOW 1/4T X 1/4T 90°
107	PS22	PHLP HD SCR 10-24 X 5/8
108	PH29339108	ELBOW 5/16N X 1/8T 90°
109	PH29339109	SOLENOID VALVE
110	PH29339110	T-FITTING 5/16N X 5/16N X 1/8T
111	PH29339111	PLASTIC CONNECTOR 1/4N X 1/4T
112	PH29339112	MANIFOLD 1/4N
113	P04869113	PLASTIC CONNECTOR 5/16N X 1/4T
114	P04869114	BRONZE ELBOW 1/4T X 1/8T-90
115	PH29339115	PLASTIC CONNECTOR 1/4N X 1/8T 90°
116	PH29339116	PLASTIC CONNECTOR 1/4N X 1/8T 90°
117	PH29339117	THROTTLE VALVE 1/8"
118	P04869118	PLASTIC CONNECTOR 1/4N X 1/8T
119	P04869119	BRONZE CONNECTOR 1/4N X 1/4
120	P04869120	PLASTIC CONNECTOR 1/4N X 3/8T
121	PH29339121	PLASTIC CONNECTOR 1/4N X 1/8T

REF	PART #	DESCRIPTION
122	PH29339122	AIR SWITCH 1/8"
123	PH29339123	CONNECTOR 1/4N X 1/8T
124	PH29339124	CONNECTOR 1/4N X 1/8T 90°
125	P04869125	BUFFER 1/8"(BRONZE)
126	P04869126	DIAPHRAGM ASSEMBLY
127	PH29339127	CONNECTOR 5/16N X 1/8T 90°
128	PH29339128	8 X 900MM FLEXIBLE HOSE
129	PH29339129	8 X 1650MM FLEXIBLE HOSE
130	P04869130	6MM FLEXIBLE HOSE
131	P04869131	6 X 1700MM FLEXIBLE HOSE (G0486)
131	P04879131	6 X 1800MM FLEXIBLE HOSE (G0487)
132	P04869132	6 X 800MM FLEXIBLE HOSE (G0486)
132	P04879132	6 X 950MM FLEXIBLE HOSE (G0487)
133	PH29339133	6 X 600MM FLEXIBLE HOSE
134A	PH29339134	6 X 650MM FLEXIBLE HOSE FRONT
134B	PH29339134	6 X 300MM FLEXIBLE HOSE REAR
135	PH29339135	6 X 700MM FLEXIBLE HOSE
136	PH29339136	6 X 350MM FLEXIBLE HOSE
137	PH29339137	6 X 700MM FLEXIBLE HOSE
138	P04869138	6 X 1500MM FLEXIBLE HOSE (G0486)
138	P04879138	6 X 1700MM FLEXIBLE HOSE (G0487)



# Machine Label Diagram

## 9000 Series Parts

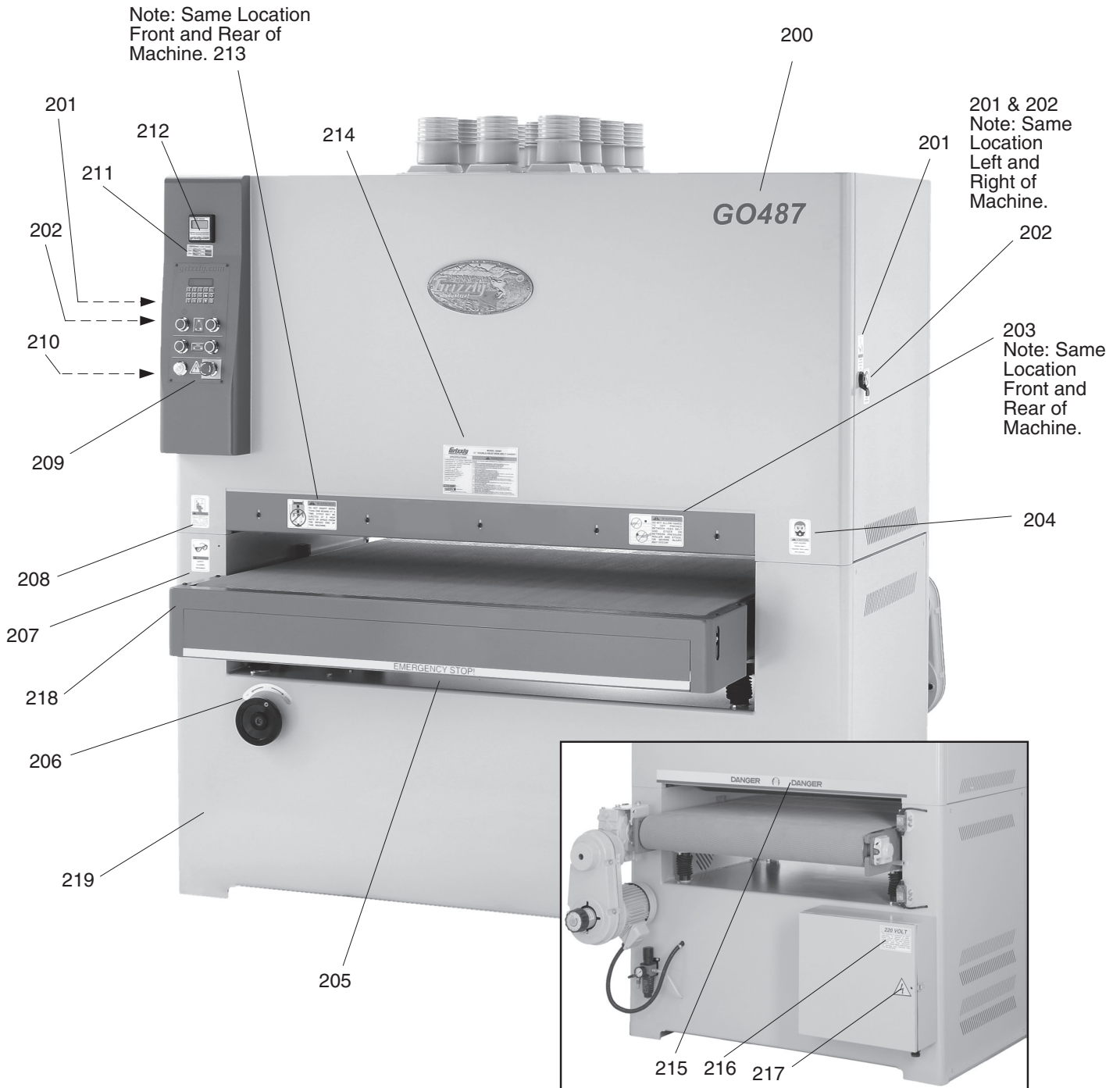

## WARNING

Safety labels warn about machine hazards and ways to prevent injury. The owner of this machine **MUST** maintain the original location and readability of the labels on the machine. If any label is removed or becomes unreadable, **REPLACE** that label before using the machine again. Contact Grizzly at (800) 523-4777 or [www.grizzly.com](http://www.grizzly.com) to order new labels.



# Machine Label List

REF	PART #	DESCRIPTION
200	P04869200	MODEL G0486 LABEL
200	P04879200	MODEL G0487 LABEL
201	PLABEL-13	UNPLUG SANDER LABEL
202	PLABEL-30	DOOR CLOSED LABEL
203	PLABEL-22	HAND PINCH IN BELT LABEL
204	PLABEL-32	DUST MASK LABEL
205	P05819205	EMERGENCY STRIPE LABEL
206	PH29339206	ROTATION LABEL LABEL
207	PLABEL-11	SAFETY GLASSES LABEL
208	PLABEL-12	READ MANUAL LABEL
209	PH29339209	CONTROL PANEL FACE LABEL
210	PLABEL-27	CONVERSION CHART LABEL

REF	PART #	DESCRIPTION
211	P04869211	G0486 AMP SCALE LABEL
211	P04879211	G0487 AMP SCALE LABEL
212	PH29339212	LOAD METER FACE LABEL
213	PLABEL-17	FEED ONLY ONE LABEL
214	P04869214	G0486 DATA LABEL
214	P04879214	G0487 DATA LABEL
215	P05819215	DANGER STRIPE LABEL
216	PH29339216	220-VOLT, 3 PHASE PREWIRED LABEL
217	PLABEL-14	ELECTRICITY
218	PPAINT-1	PAINT-GRIZZLY GREEN
219	PPAINT-11	PUTTY TOUCH UP PAINT



# WARRANTY & RETURNS

---

---

Grizzly Industrial, Inc. warrants every product it sells for a period of **1 year** to the original purchaser from the date of purchase. This warranty does not apply to defects due directly or indirectly to misuse, abuse, negligence, accidents, repairs or alterations or lack of maintenance. This is Grizzly's sole written warranty and any and all warranties that may be implied by law, including any merchantability or fitness, for any particular purpose, are hereby limited to the duration of this written warranty. We do not warrant or represent that the merchandise complies with the provisions of any law or acts unless the manufacturer so warrants. In no event shall Grizzly's liability under this warranty exceed the purchase price paid for the product and any legal actions brought against Grizzly shall be tried in the State of Washington, County of Whatcom.

We shall in no event be liable for death, injuries to persons or property or for incidental, contingent, special, or consequential damages arising from the use of our products.

To take advantage of this warranty, contact us by mail or phone and give us all the details. We will then issue you a "Return Number," which must be clearly posted on the outside as well as the inside of the carton. We will not accept any item back without this number. Proof of purchase must accompany the merchandise.

The manufacturers reserve the right to change specifications at any time because they constantly strive to achieve better quality equipment. We make every effort to ensure that our products meet high quality and durability standards and we hope you never need to use this warranty.

Please feel free to write or call us if you have any questions about the machine or the manual.

Thank you again for your business and continued support. We hope to serve you again soon.





# WARRANTY CARD

Name \_\_\_\_\_

Street \_\_\_\_\_

City \_\_\_\_\_ State \_\_\_\_\_ Zip \_\_\_\_\_

Phone # \_\_\_\_\_ Email \_\_\_\_\_ Invoice # \_\_\_\_\_

Model # \_\_\_\_\_ Order # \_\_\_\_\_ Serial # \_\_\_\_\_

*The following information is given on a voluntary basis. It will be used for marketing purposes to help us develop better products and services. **Of course, all information is strictly confidential.***

1. How did you learn about us?

- Advertisement
- Card Deck
- Friend
- Website
- Catalog
- Other:

2. Which of the following magazines do you subscribe to?

- |   |  |   |
|---|--|---|
| <input type="checkbox"/> Cabinet Maker          | <input type="checkbox"/> Popular Mechanics   | <input type="checkbox"/> Today's Homeowner    |
| <input type="checkbox"/> Family Handyman        | <input type="checkbox"/> Popular Science     | <input type="checkbox"/> Wood                 |
| <input type="checkbox"/> Hand Loader            | <input type="checkbox"/> Popular Woodworking | <input type="checkbox"/> Wooden Boat          |
| <input type="checkbox"/> Handy                  | <input type="checkbox"/> Practical Homeowner | <input type="checkbox"/> Woodshop News        |
| <input type="checkbox"/> Home Shop Machinist    | <input type="checkbox"/> Precision Shooter   | <input type="checkbox"/> Woodsmith            |
| <input type="checkbox"/> Journal of Light Cont. | <input type="checkbox"/> Projects in Metal   | <input type="checkbox"/> Woodwork             |
| <input type="checkbox"/> Live Steam             | <input type="checkbox"/> RC Modeler          | <input type="checkbox"/> Woodworker West      |
| <input type="checkbox"/> Model Airplane News    | <input type="checkbox"/> Rifle               | <input type="checkbox"/> Woodworker's Journal |
| <input type="checkbox"/> Modeltec               | <input type="checkbox"/> Shop Notes          | <input type="checkbox"/> Other:               |
| <input type="checkbox"/> Old House Journal      | <input type="checkbox"/> Shotgun News        |   |

3. What is your annual household income?

- \$20,000-\$29,000
- \$30,000-\$39,000
- \$40,000-\$49,000
- \$50,000-\$59,000
- \$60,000-\$69,000
- \$70,000+

4. What is your age group?

- 20-29
- 30-39
- 40-49
- 50-59
- 60-69
- 70+

5. How long have you been a woodworker/metalworker?

- 0-2 Years
- 2-8 Years
- 8-20 Years
- 20+ Years

6. How many of your machines or tools are Grizzly?

- 0-2
- 3-5
- 6-9
- 10+

7. Do you think your machine represents a good value?  Yes  No

8. Would you recommend Grizzly Industrial to a friend?  Yes  No

9. Would you allow us to use your name as a reference for Grizzly customers in your area?  
Note: *We never use names more than 3 times.*  Yes  No

10. Comments: \_\_\_\_\_

---



---



---

CUT ALONG DOTTED LINE

FOLD ALONG DOTTED LINE

\_\_\_\_\_  
\_\_\_\_\_  
\_\_\_\_\_



Place  
Stamp  
Here



**GRIZZLY INDUSTRIAL, INC.**  
**P.O. BOX 2069**  
**BELLINGHAM, WA 98227-2069**



FOLD ALONG DOTTED LINE

Send a Grizzly Catalog to a friend:

Name \_\_\_\_\_  
Street \_\_\_\_\_  
City \_\_\_\_\_ State \_\_\_\_\_ Zip \_\_\_\_\_

TAPE ALONG EDGES--PLEASE DO NOT STAPLE



# *grizzly.com*

**TOOL WEBSITE**

Buy Direct and Save with Grizzly® – Trusted, Proven and a Great Value!

*Visit Our Website Today And Discover  
Why Grizzly® Is The Industry Leader!*

- SECURE ORDERING
- ORDERS SHIPPED WITHIN 24 HOURS
- E-MAIL RESPONSE WITHIN ONE HOUR

-OR-

Call Today For A **FREE**  
Full Color Catalog

**1-800-523-4777**

