

READ THIS FIRST



Model G0643

IMPORTANT UPDATE

For Machines Mfd. Since 05/25
and Owner's Manual Revised 11/17

For questions or help with this product contact Tech Support at (570) 546-9663 or techsupport@grizzly.com

The following changes were recently made since the owner's manual was printed:

- Pressure switch added.
- Parts have changed.
- Test Run has changed.
- Electrical Components and Wiring Diagrams have changed.

Aside from this information, all other content in the owner's manual applies and MUST be read and understood for your own safety. **IMPORTANT: Keep this update with the owner's manual for future reference.**

For questions or help, contact our Tech Support at (570) 546-9663 or techsupport@grizzly.com.

Revised Parts

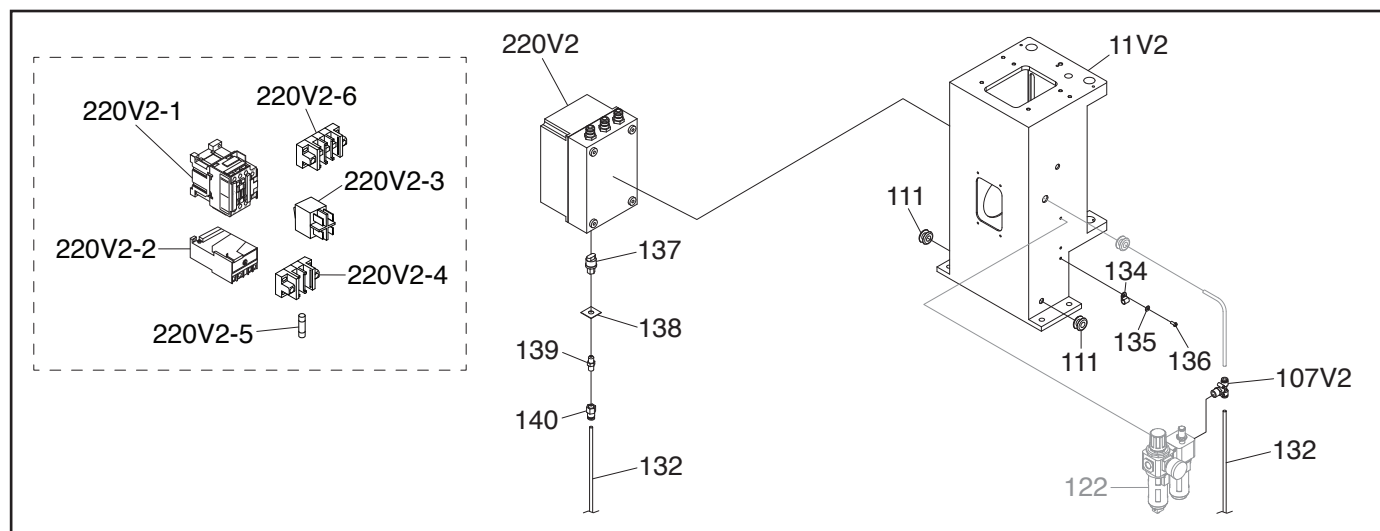

REF	PART #	DESCRIPTION
11V2	P0643011V2	COLUMN V2.05.25
107V2	P0643107V2	TEE ADAPTER 3/8" PT X 8MM X 8MM V2.05.25
111	P0643111	RUBBER GROMMET
132	P0643132	PU TUBE 5 X 8 X 650MM
134	P0643134	CABLE CLAMP 3/8"
135	P0643135	FLAT WASHER 5MM
136	P0643136	PHLP HD SCR M5-.8 X 12
137	P0643137	PRESSURE SWITCH SUPCO SLP-2550
138	P0643138	PRESSURE SWITCH GASKET

REF	PART #	DESCRIPTION
139	P0643139	PIPE FITTING 1/4" PT
140	P0643140	PIPE ADAPTER 1/4" PT X 8MM
220V2	P0643220V2	ELECTRICAL BOX 220V V2.05.25
220V2-1	P0643220V2-1	CONTACTOR TECO CN18 220V
220V2-2	P0643220V2-2	OL RELAY TECO RHU-10K/12.5K1 8.5-12.5A
220V2-3	P0643220V2-3	RELAY IDEC RU25-NF-A220 10A 250VAC
220V2-4	P0643220V2-4	FUSE HOLDER
220V2-5	P0643220V2-5	FUSE 3A 250V 0.18" FAST-ACTING, GLASS
220V2-6	P0643220V2-6	TERMINAL BLOCK 6 POLE

COPYRIGHT © NOVEMBER, 2025 BY GRIZZLY INDUSTRIAL, INC.
**WARNING: NO PORTION OF THIS MANUAL MAY BE REPRODUCED IN ANY SHAPE
OR FORM WITHOUT THE WRITTEN APPROVAL OF GRIZZLY INDUSTRIAL, INC.**
#KS23742 PRINTED IN TAIWAN

Test Run

Once assembly is complete, test run the machine to ensure it is properly connected to power and safety components are functioning correctly.

If you find an unusual problem during the test run, immediately stop the machine, disconnect it from power, and fix the problem **BEFORE** operating the machine again. The **Troubleshooting** table in the **SERVICE** section of this manual can help.

The Test Run consists of verifying the following: 1) The motor powers up and runs correctly, 2) the headstock limit switch safety feature functions properly, 3) the EMERGENCY STOP button safety feature functions properly, and 4) the pressure switch safety feature functions properly.

WARNING

Serious injury or death can result from using this machine BEFORE understanding its controls and related safety information. DO NOT operate, or allow others to operate, machine until the information is understood.

WARNING

DO NOT start machine until all preceding setup instructions have been performed. Operating an improperly set up machine may result in malfunction or unexpected results that can lead to serious injury, death, or machine/property damage.

To test run machine:

1. Clear all setup tools away from machine.
IMPORTANT: If there are boring bits installed in machine, remove them.
2. Press EMERGENCY STOP button in.
3. Verify boring head guards are in place and are free to move up as boring head comes down.
4. Make sure air pressure gauge on air regulator reads 70 PSI.
5. Ensure machine is properly lubricated (see **Lubrication** on **Page 23** of owner's manual).
6. Adjust drilling depth to "000.50" (see **Adjusting Drilling Depth** on **Page 19** of owner's manual).
7. Connect machine to power by inserting power cord plug into a matching receptacle.
8. Twist EMERGENCY STOP button clockwise until it springs out (see **Figure 15**). This resets button so machine can start.



Figure 15. Resetting EMERGENCY STOP button.



9. Press power ON button to turn machine **ON**.
 - Green lamp on button should illuminate.
10. Press foot switch to lower boring head and start chuck rotation. Verify motor starts up and runs smoothly without any unusual problems or noises, and boring chucks rotate.
11. Release foot switch and verify boring chucks stop rotating when boring head contacts headstock limit switch.
 - If boring chucks *stop* rotating, safety feature of headstock limit switch is working correctly.
 - If boring chucks *continue* rotating, safety feature of headstock limit switch is NOT working properly and must be adjusted before further using machine. Refer to **Adjusting Headstock Limit Switch** on **Page 28** of owner's manual.
12. Press foot switch to lower boring head and start chuck rotation, then press EMERGENCY STOP button to turn machine **OFF**.
13. WITHOUT resetting EMERGENCY STOP button, try to start machine by pressing power ON button, then pressing foot switch. Boring head should lower, but machine should not start.
 - If machine *does not* start, safety feature of EMERGENCY STOP button is working correctly.
 - If machine *does* start, immediately turn it **OFF** and disconnect power. Safety feature of EMERGENCY STOP button is NOT working properly and must be replaced before further using machine.
14. Twist EMERGENCY STOP button clockwise until it springs out, then press power ON button to turn machine **ON**.
15. Reduce pressure on air regulator until air pressure gauge reads 25 PSI or less.
 - Green lamp on power ON button should extinguish.
16. WITHOUT increasing air pressure, try to start machine by pressing power ON button, then pressing foot switch. Machine should not start.
 - If machine *does not* start, safety feature of pressure switch is working correctly.
 - If machine *does* start, immediately turn it **OFF** and disconnect power. Safety feature of pressure switch is NOT working properly and must be replaced before further using machine.
17. Release foot switch and press EMERGENCY STOP button to turn machine **OFF**.

Congratulations! Test Run is complete.



WIRING

These pages are current at the time of printing. However, in the spirit of improvement, we may make changes to the electrical systems of future machines. Compare the manufacture date of your machine to the one stated in this manual, and study this section carefully.

If there are differences between your machine and what is shown in this section, call Technical Support at (570) 546-9663 for assistance BEFORE making any changes to the wiring on your machine. An updated wiring diagram may be available. **Note:** Please gather the serial number and manufacture date of your machine before calling. This information can be found on the main machine label.

WARNING

Wiring Safety Instructions

SHOCK HAZARD. Working on wiring that is connected to a power source is extremely dangerous. Touching electrified parts will result in personal injury including but not limited to severe burns, electrocution, or death. Disconnect the power from the machine before servicing electrical components!

MODIFICATIONS. Modifying the wiring beyond what is shown in the diagram may lead to unpredictable results, including serious injury or fire. This includes the installation of unapproved after-market parts.

WIRE CONNECTIONS. All connections must be tight to prevent wires from loosening during machine operation. Double-check all wires disconnected or connected during any wiring task to ensure tight connections.

CIRCUIT REQUIREMENTS. You MUST follow the requirements at the beginning of this manual when connecting your machine to a power source.

WIRE/COMPONENT DAMAGE. Damaged wires or components increase the risk of serious personal injury, fire, or machine damage. If you notice that any wires or components are damaged while performing a wiring task, replace those wires or components.

MOTOR WIRING. The motor wiring shown in these diagrams is current at the time of printing but may not match your machine. If you find this to be the case, use the wiring diagram inside the motor junction box.















CAPACITORS/INVERTERS. Some capacitors and power inverters store an electrical charge for up to 10 minutes after being disconnected from the power source. To reduce the risk of being shocked, wait at least this long before working on capacitors.

EXPERIENCING DIFFICULTIES. If you are experiencing difficulties understanding the information included in this section, contact our Technical Support at (570) 546-9663.

NOTICE

The photos and diagrams included in this section are best viewed in color. You can view these pages in color at www.grizzly.com.

COLOR KEY

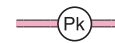
BLACK 	BLUE 	YELLOW 	LIGHT BLUE 
WHITE 	BROWN 	YELLOW GREEN 	BLUE WHITE 
GREEN 	GRAY 	PURPLE 	TURQUOISE 
RED 	ORANGE 	PINK 	



Electrical Components

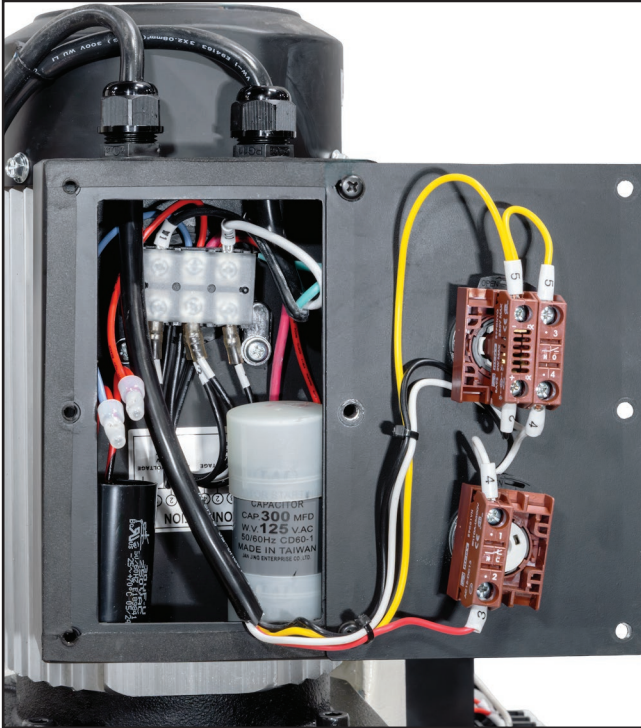

Figure 39. Motor junction box and control panel wiring.

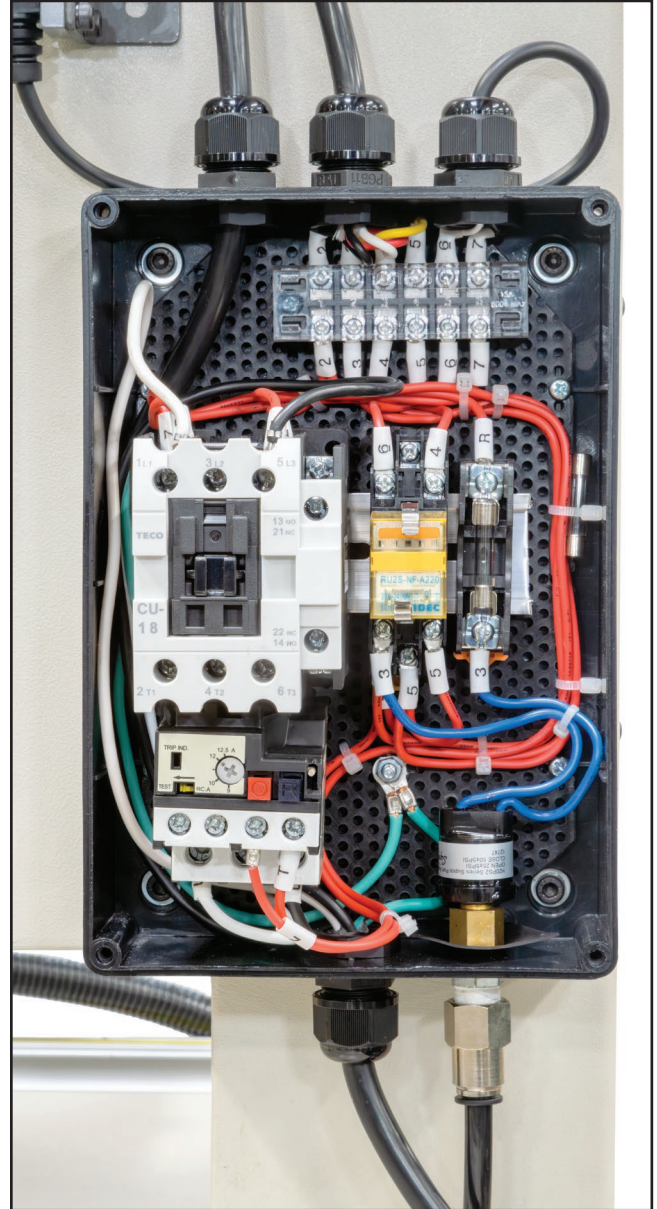
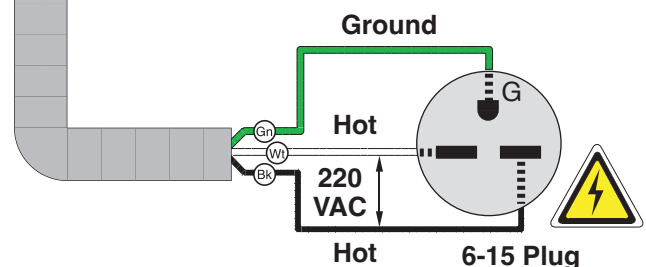
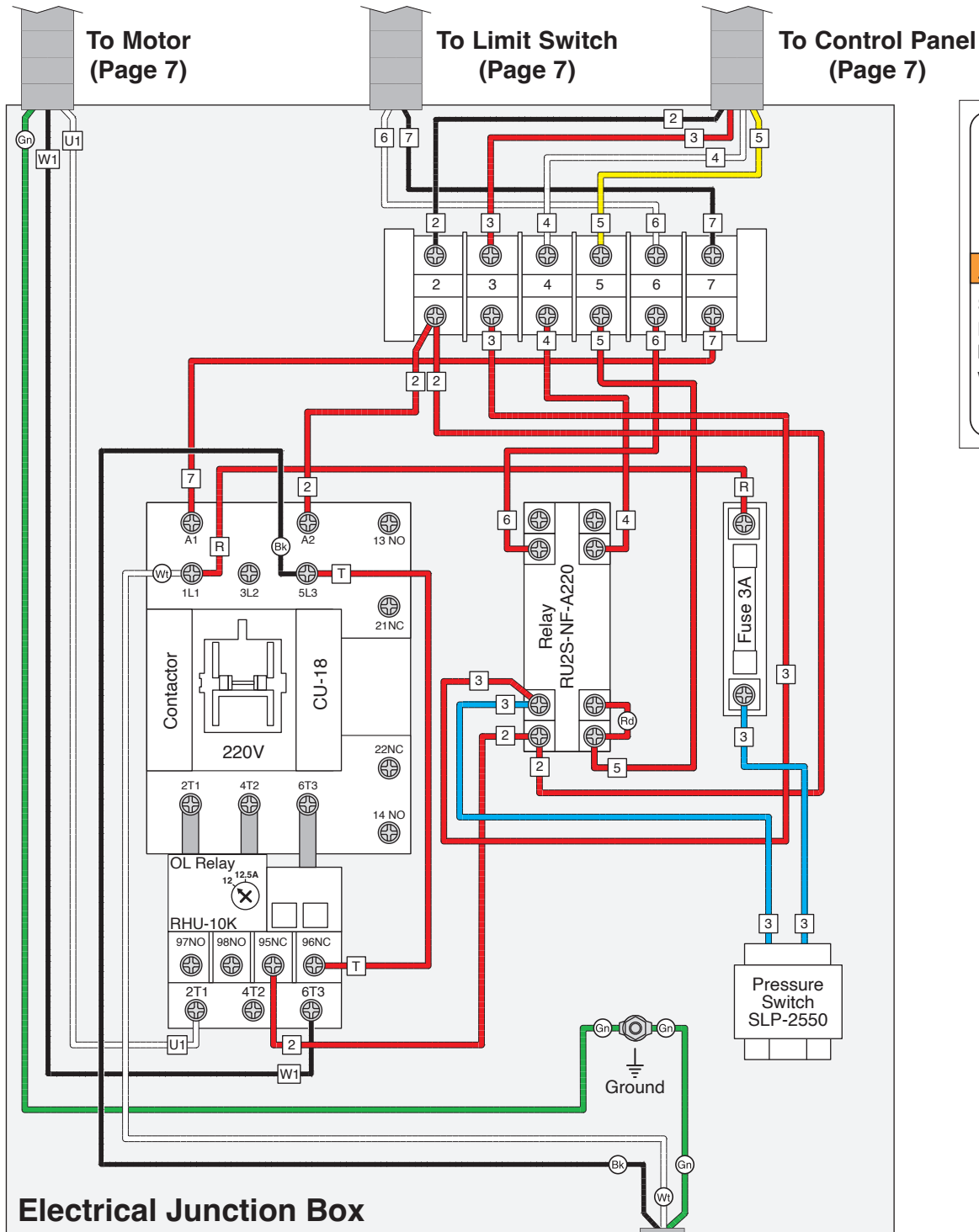

Figure 40. Electrical junction box wiring.



Electrical Box Wiring Diagram



Control System Wiring Diagram

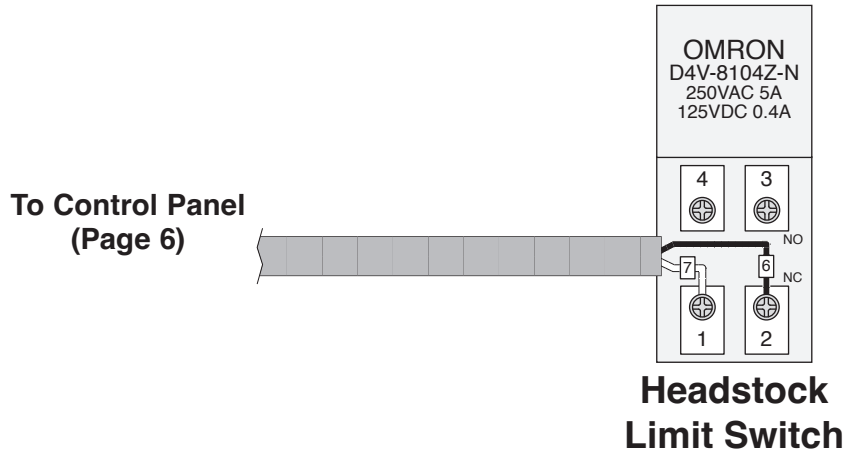
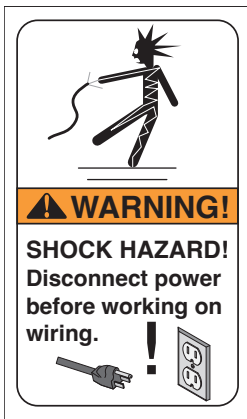
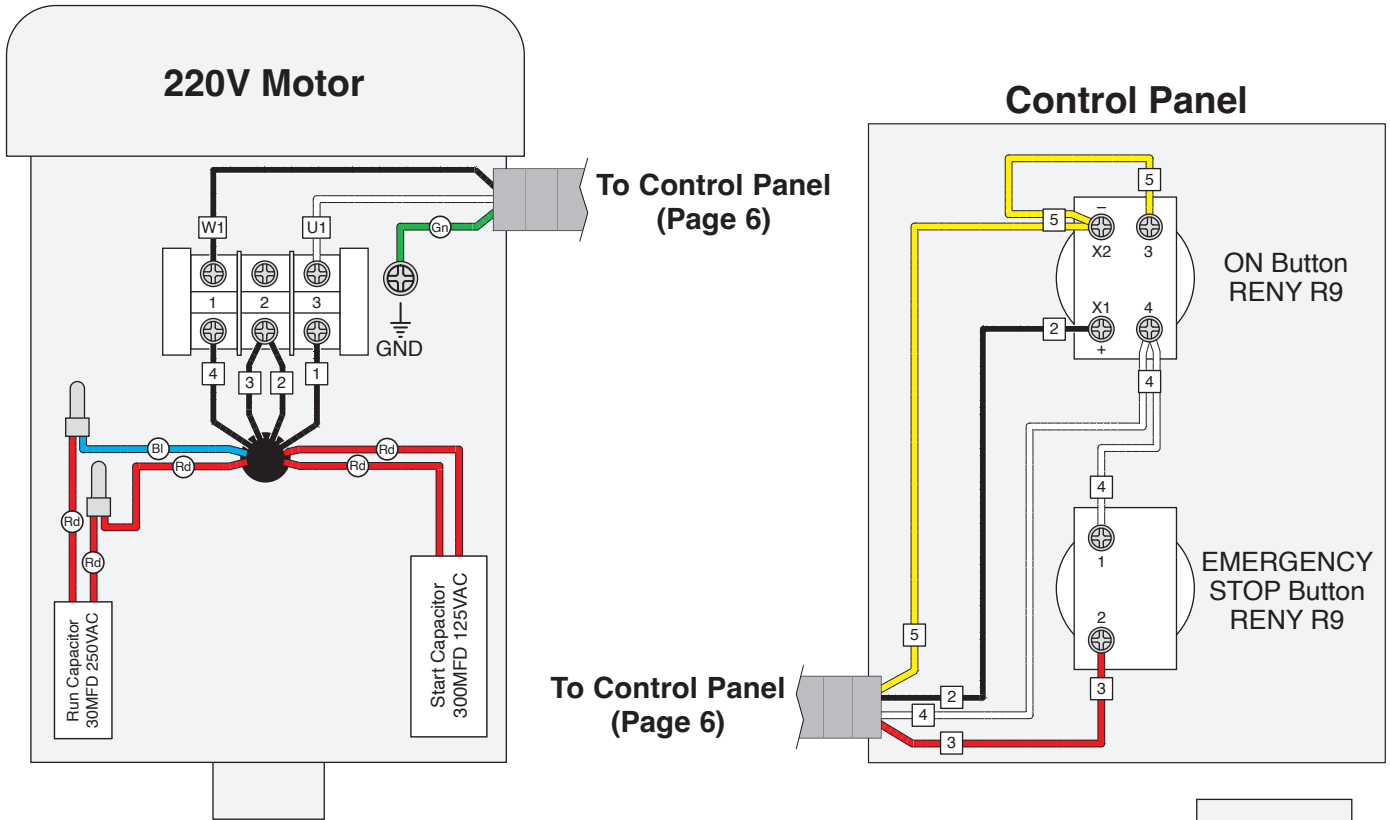

grizzly.com[®]

TOOL WEBSITE

Buy Direct and Save with Grizzly[®] – Trusted, Proven and a Great Value!
~Since 1983~

*Visit Our Website Today For
Current Specials!*

**ORDER
24 HOURS A DAY!
1-800-523-4777**



Grizzly *Industrial, Inc.*®

MODEL G0643 21-BIT LINE BORING MACHINE OWNER'S MANUAL



COPYRIGHT © NOVEMBER, 2007 BY GRIZZLY INDUSTRIAL, INC., REVISED NOVEMBER, 2017 (HE)
**WARNING: NO PORTION OF THIS MANUAL MAY BE REPRODUCED IN ANY SHAPE
OR FORM WITHOUT THE WRITTEN APPROVAL OF GRIZZLY INDUSTRIAL, INC.**
(FOR MODELS MANUFACTURED SINCE 9/09) #TS9905 PRINTED IN TAIWAN



WARNING!

This manual provides critical safety instructions on the proper setup, operation, maintenance, and service of this machine/tool. Save this document, refer to it often, and use it to instruct other operators.

Failure to read, understand and follow the instructions in this manual may result in fire or serious personal injury—including amputation, electrocution, or death.

The owner of this machine/tool is solely responsible for its safe use. This responsibility includes but is not limited to proper installation in a safe environment, personnel training and usage authorization, proper inspection and maintenance, manual availability and comprehension, application of safety devices, cutting/sanding/grinding tool integrity, and the usage of personal protective equipment.

The manufacturer will not be held liable for injury or property damage from negligence, improper training, machine modifications or misuse.



WARNING!

Some dust created by power sanding, sawing, grinding, drilling, and other construction activities contains chemicals known to the State of California to cause cancer, birth defects or other reproductive harm. Some examples of these chemicals are:

- **Lead from lead-based paints.**
- **Crystalline silica from bricks, cement and other masonry products.**
- **Arsenic and chromium from chemically-treated lumber.**

Your risk from these exposures varies, depending on how often you do this type of work. To reduce your exposure to these chemicals: Work in a well ventilated area, and work with approved safety equipment, such as those dust masks that are specially designed to filter out microscopic particles.

Table of Contents

INTRODUCTION	2	SECTION 5: ACCESSORIES	22
Foreword.....	2	SECTION 6: MAINTENANCE	23
Contact Info.....	2	Schedule.....	23
Machine Data Sheet.....	3	Cleaning.....	23
Identification.....	4	Lubrication.....	23
SECTION 1: SAFETY	5	Air Filter Reservoir.....	25
Safety Instructions for Machinery.....	5	SECTION 7: SERVICE	26
Additional Safety Instructions for Line Boring Machines.....	7	Troubleshooting.....	26
SECTION 2: CIRCUIT REQUIREMENTS	8	Adjusting Headstock Limit Switch.....	28
Rewiring to 110V.....	9	Adjusting Table Parallel to Boring Head.....	29
SECTION 3: SETUP	10	Aligning Boring Bit Height.....	30
Setup Safety.....	10	Electrical Components.....	31
Items Needed for Setup.....	10	Wiring Diagrams.....	32
Unpacking.....	10	SECTION 8: PARTS	34
Inventory.....	11	Column Breakdown.....	34
Clean Up.....	11	Air System Breakdown.....	36
Site Considerations.....	12	Electrical System Breakdown.....	38
Mounting to Shop Floor.....	12	Table Breakdown.....	40
Moving & Placing Base Unit.....	13	Cabinet & Tools Breakdown.....	42
Assembly.....	14	Boring Head Breakdown.....	44
Test Run.....	16	Label Placement & List.....	46
SECTION 4: OPERATIONS	17	WARRANTY AND RETURNS	49
Operation Safety.....	17		
Installing Boring Bits.....	17		
Adjusting Downfeed Speed.....	18		
Adjusting Drilling Depth.....	19		
Adjusting Hold-down Height.....	20		
Positioning the Workpiece.....	20		
Drilling Overview.....	21		

INTRODUCTION

Manual Accuracy

We are proud to offer this document with your new machine! We've made every effort to be exact with the instructions, specifications, drawings, and photographs of the machine we used when writing this manual. However, sometimes we still make an occasional mistake.

Also, owing to our policy of continuous improvement, **your machine may not exactly match the manual**. If you find this to be the case, and the difference between the manual and machine leaves you in doubt, immediately call our technical support for updates or clarification.

For your convenience, we post all available documentation on our website at **www.grizzly.com**. Any updates to this document will be reflected on our website as soon as complete.

Contact Info

We stand behind our machines! If you have questions or need help, contact us with the information below. Before contacting, make sure you get the **serial number** and **manufacture date** from the machine ID label. This will help us help you faster.

Grizzly Technical Support
1815 W. Battlefield
Springfield, MO 65807
Phone: (570) 546-9663
Email: techsupport@grizzly.com

We want your feedback on this manual. What did you like about it? Where could it be improved? Please take a few minutes to give us feedback.

Grizzly Documentation Manager
P.O. Box 2069
Bellingham, WA 98227-2069
Email: manuals@grizzly.com





MACHINE DATA SHEET

Customer Service #: (570) 546-9663 • To Order Call: (800) 523-4777 • Fax #: (800) 438-5901

MODEL G0643 21 BIT LINE BORING MACHINE

Product Dimensions:

Table Size 43⁵/₁₆"W x 15³/₄"D
 Overall Size..... 75"W x 28³/₈"D x 58¹/₈"H
 Machine Weight 385 lbs.
 Base Footprint..... 36¹/₄"W x 28³/₈"D
 Table Height..... 33¹/₄"

Shipping Dimensions:

Shipping Size 42¹/₂"W x 34"D x 68⁷/₈"H
 Shipping Weight..... 550 lbs.

Electrical:

Switch..... ON/OFF Push Button, Magnetic with Thermal Overload Protection
 Cord Length 118"
 Cord Gauge 14 AWG

Motor:

Type TEFC
 Horsepower..... 2 HP
 Phase/Voltage..... Single Phase / 110V/220V (Prewired 220V)
 Cycle/RPM 60Hz/3450RPM
 Amps..... 20.8A/10.4A
 Bearings..... Shielded and Lubricated Ball Bearings

Main Specifications:

Operation Pneumatic
 No. of Spindles on Boring Head 21 Spindles (Left 10 + Right 11)
 Distance Between Spindle Centers 32MM
 Thread..... 10MM (Boring Bit Shaft)
 Max. Depth of Stroke 3³/₈"
 Max. Boring Depth from Edge 8"
 Back Fence (Horizontal Fence Stops) 74³/₄"
 Back Fence Stops..... 2 pcs
 Cross Fence Stops (Vertical Fence)..... 2 pcs
 Air Requirement 70 PSI

Construction

Shaft of Rail SUJ-2 High-Carbon Anti-friction Steel Slide Shafts
 Rail Bearings..... Slide Bush Linear Bearing
 Boring Head..... Steel Gear Heads
 Stand..... Sheet Metal
 Headstock Sheet Metal
 Head Carriage..... Aluminum

Features:

Tolerance of Swing Boring Head +/- 0.2MM
 Clear PVC Guard
 Down Feed Stroke Digital Position Indicator
 Back Fence and Cross Fence Scale Position Indicator



Identification

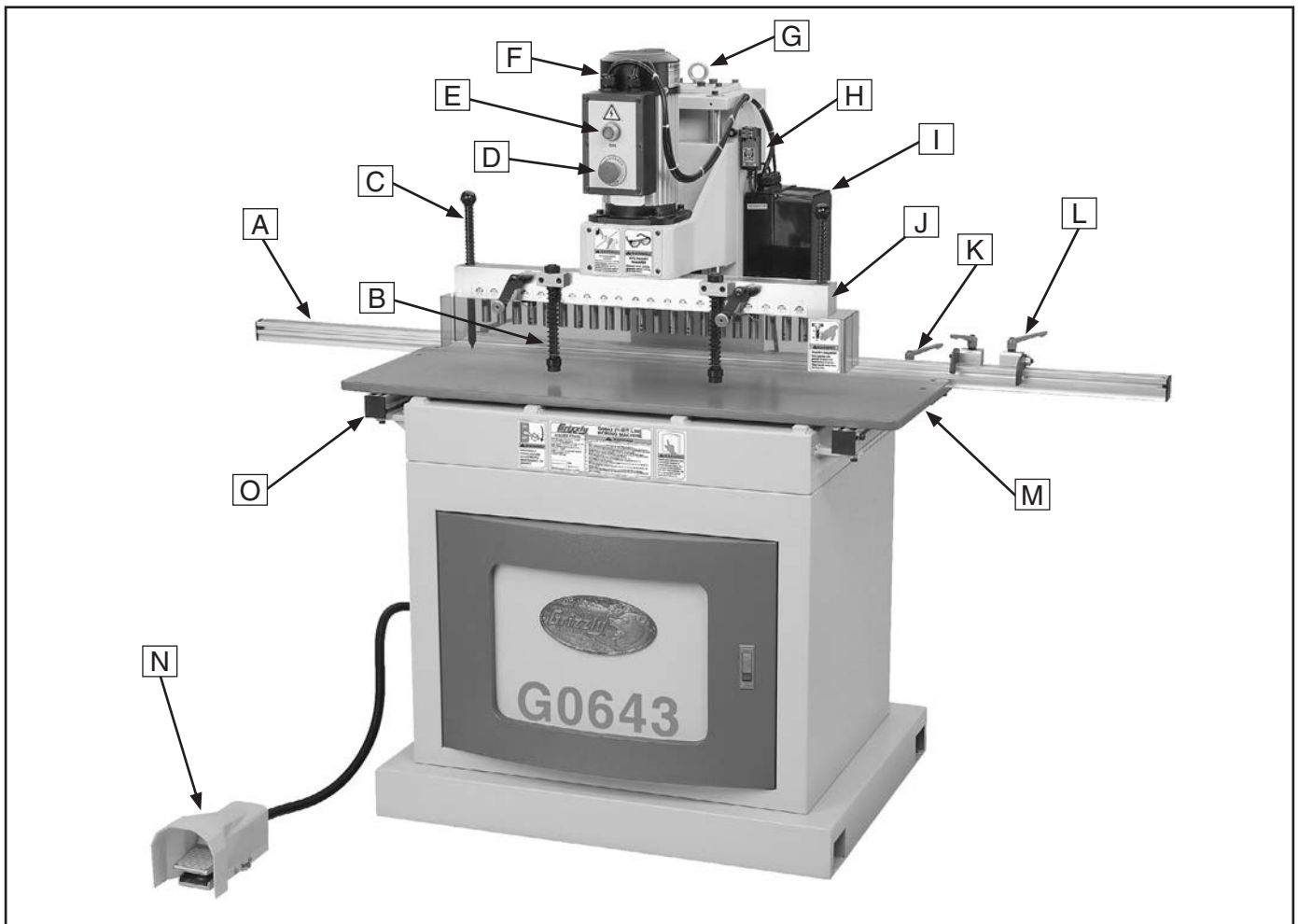

Figure 1. Model G0643 identification.

- A.** Longitudinal Fence and Scale
- B.** Workpiece Hold-down
- C.** Indexing Pin
- D.** Emergency Stop Button
- E.** Power On Button and Lamp
- F.** Motor 2 HP
- G.** Lifting Eye Bolt
- H.** Headstock Limit Switch

- I.** Electrical Box
- J.** Boring Head
- K.** Cross Fence Locking Lever
- L.** Longitudinal Fence Locking Lever & Stop
- M.** Table
- N.** Foot Switch
- O.** Cross Fence and Scale



SECTION 1: SAFETY

For Your Own Safety, Read Instruction Manual Before Operating This Machine

The purpose of safety symbols is to attract your attention to possible hazardous conditions. This manual uses a series of symbols and signal words intended to convey the level of importance of the safety messages. The progression of symbols is described below. Remember that safety messages by themselves do not eliminate danger and are not a substitute for proper accident prevention measures. Always use common sense and good judgment.



Indicates an imminently hazardous situation which, if not avoided, **WILL** result in death or serious injury.



Indicates a potentially hazardous situation which, if not avoided, **COULD** result in death or serious injury.



Indicates a potentially hazardous situation which, if not avoided, **MAY** result in minor or moderate injury. It may also be used to alert against unsafe practices.

NOTICE

This symbol is used to alert the user to useful information about proper operation of the machine.

Safety Instructions for Machinery



OWNER'S MANUAL. Read and understand this owner's manual **BEFORE** using machine.

TRAINED OPERATORS ONLY. Untrained operators have a higher risk of being hurt or killed. Only allow trained/supervised people to use this machine. When machine is not being used, disconnect power, remove switch keys, or lock-out machine to prevent unauthorized use—especially around children. Make your workshop kid proof!

DANGEROUS ENVIRONMENTS. Do not use machinery in areas that are wet, cluttered, or have poor lighting. Operating machinery in these areas greatly increases the risk of accidents and injury.

MENTAL ALERTNESS REQUIRED. Full mental alertness is required for safe operation of machinery. Never operate under the influence of drugs or alcohol, when tired, or when distracted.

ELECTRICAL EQUIPMENT INJURY RISKS. You can be shocked, burned, or killed by touching live electrical components or improperly grounded machinery. To reduce this risk, only allow qualified service personnel to do electrical installation or repair work, and always disconnect power before accessing or exposing electrical equipment.

DISCONNECT POWER FIRST. Always disconnect machine from power supply **BEFORE** making adjustments, changing tooling, or servicing machine. This prevents an injury risk from unintended startup or contact with live electrical components.

EYE PROTECTION. Always wear ANSI-approved safety glasses or a face shield when operating or observing machinery to reduce the risk of eye injury or blindness from flying particles. Everyday eyeglasses are **NOT** approved safety glasses.



WARNING

WEARING PROPER APPAREL. Do not wear clothing, apparel or jewelry that can become entangled in moving parts. Always tie back or cover long hair. Wear non-slip footwear to reduce risk of slipping and losing control or accidentally contacting cutting tool or moving parts.

HAZARDOUS DUST. Dust created by machinery operations may cause cancer, birth defects, or long-term respiratory damage. Be aware of dust hazards associated with each workpiece material. Always wear a NIOSH-approved respirator to reduce your risk.

HEARING PROTECTION. Always wear hearing protection when operating or observing loud machinery. Extended exposure to this noise without hearing protection can cause permanent hearing loss.

REMOVE ADJUSTING TOOLS. Tools left on machinery can become dangerous projectiles upon startup. Never leave chuck keys, wrenches, or any other tools on machine. Always verify removal before starting!

USE CORRECT TOOL FOR THE JOB. Only use this tool for its intended purpose—do not force it or an attachment to do a job for which it was not designed. Never make unapproved modifications—modifying tool or using it differently than intended may result in malfunction or mechanical failure that can lead to personal injury or death!

AWKWARD POSITIONS. Keep proper footing and balance at all times when operating machine. Do not overreach! Avoid awkward hand positions that make workpiece control difficult or increase the risk of accidental injury.

CHILDREN & BYSTANDERS. Keep children and bystanders at a safe distance from the work area. Stop using machine if they become a distraction.

GUARDS & COVERS. Guards and covers reduce accidental contact with moving parts or flying debris. Make sure they are properly installed, undamaged, and working correctly **BEFORE** operating machine.

FORCING MACHINERY. Do not force machine. It will do the job safer and better at the rate for which it was designed.

NEVER STAND ON MACHINE. Serious injury may occur if machine is tipped or if the cutting tool is unintentionally contacted.

STABLE MACHINE. Unexpected movement during operation greatly increases risk of injury or loss of control. Before starting, verify machine is stable and mobile base (if used) is locked.

USE RECOMMENDED ACCESSORIES. Consult this owner's manual or the manufacturer for recommended accessories. Using improper accessories will increase the risk of serious injury.

UNATTENDED OPERATION. To reduce the risk of accidental injury, turn machine **OFF** and ensure all moving parts completely stop before walking away. Never leave machine running while unattended.

MAINTAIN WITH CARE. Follow all maintenance instructions and lubrication schedules to keep machine in good working condition. A machine that is improperly maintained could malfunction, leading to serious personal injury or death.

DAMAGED PARTS. Regularly inspect machine for damaged, loose, or mis-adjusted parts—or any condition that could affect safe operation. Immediately repair/replace **BEFORE** operating machine. For your own safety, **DO NOT** operate machine with damaged parts!

MAINTAIN POWER CORDS. When disconnecting cord-connected machines from power, grab and pull the plug—**NOT** the cord. Pulling the cord may damage the wires inside. Do not handle cord/plug with wet hands. Avoid cord damage by keeping it away from heated surfaces, high traffic areas, harsh chemicals, and wet/damp locations.

EXPERIENCING DIFFICULTIES. If at any time you experience difficulties performing the intended operation, stop using the machine! Contact our Technical Support at (570) 546-9663.



WARNING

Additional Safety Instructions for Line Boring Machines

- 1. EYE/FACE/HAND PROTECTION.** Debris from the drilling operation can be thrown at the operator. Always wear safety glasses or a face shield to protect your eyes and face during boring operations. The spinning boring bits are sharp and can seriously damage hands. Always keep hands and fingers away from the moving drill bits. **DO NOT** wear gloves when operating this machine.
- 2. GUARDS.** The boring head guard reduces the risk of debris being thrown at the operator. **DO NOT** operate this machine with the boring head guards removed.
- 3. BORING OPERATION.** The boring bits rotate with tremendous torque, especially at start up. To avoid the bits grabbing the workpiece and unexpectedly moving it, never start the machine with the boring bits pressed against the workpiece.
- 4. DULL OR WORN BITS.** Dull or damaged bits may break apart during operation, be thrown at the operator, or reduce the performance of the operation. Inspect bits before each use. **DO NOT** operate with dull or damaged bits.
- 5. SECURING WORKPIECE.** The operator's hands may be drawn into the spinning boring bits if the workpiece or table moves unexpectedly during operation. Make sure the fences are locked in place, the workpiece is firmly against the longitudinal fence, and the workpiece is fully supported.
- 6. BORING BITS.** A rapidly spinning boring bit can be thrown into the operator if it comes loose from the chuck during operation. Only use standard boring bits with a 10mm shank designed for this machine. Properly secure the bits in the chucks before beginning operations. Make sure the chuck and the installed boring bit are designed to rotate in the same direction.
- 7. SURFACE/WORKPIECE PREPARATION.** Never turn the machine **ON** before clearing the table of all tools, scrap wood, etc. Only drill wood products that are free of imperfections or foreign objects. Never use this machine to drill metal.
- 8. EXPERIENCING DIFFICULTIES.** If at any time you are experiencing difficulties performing the intended operation, stop using the machine! Contact our Technical Support at (570) 546-9663.

WARNING

Like all machinery there is potential danger when operating this machine. Accidents are frequently caused by lack of familiarity or failure to pay attention. Use this machine with respect and caution to lessen the possibility of operator injury. If normal safety precautions are overlooked or ignored, serious personal injury may occur.

CAUTION

No list of safety guidelines can be complete. Every shop environment is different. Always consider safety first, as it applies to your individual working conditions. Use this and other machinery with caution and respect. Failure to do so could result in serious personal injury, damage to equipment, or poor work results.



SECTION 2: CIRCUIT REQUIREMENTS

! WARNING
 Serious personal injury could occur if you connect the machine to power before completing the setup process. **DO NOT** connect the machine to the power until instructed later in this manual.

! WARNING
 Electrocutation or fire could result if machine is not grounded and installed in compliance with electrical codes. Compliance **MUST** be verified by a qualified electrician!

NOTICE
 The Model G0643 is prewired for 220V, single-phase. If you plan to operate the machine at 110V, the motor must be rewired, and the 110V version of the electrical box and *ON* switch must be installed. Refer to *Rewiring to 110V* on Page 9 for detailed instructions.

Full Load Amperage Draw

Motor Draw at 110V 20.8 Amps
 Motor Draw at 220V (prewired) 10.4 Amps

Circuit Requirements

You **MUST** connect your machine to a grounded circuit that is rated for the amperage given below. Never replace a circuit breaker on an existing circuit with one of higher amperage without consulting a qualified electrician to ensure compliance with wiring codes. **If you are unsure about the wiring codes in your area or you plan to connect your machine to a shared circuit, consult a qualified electrician.**

Minimum 110V Circuit 30 Amps
 Minimum 220V Circuit (pre-wired) 15 Amps

Power Connection Device

The power connection device depends on the type of installed or planned service. We recommend using one of the devices shown in **Figure 2**, depending on the voltage being used.

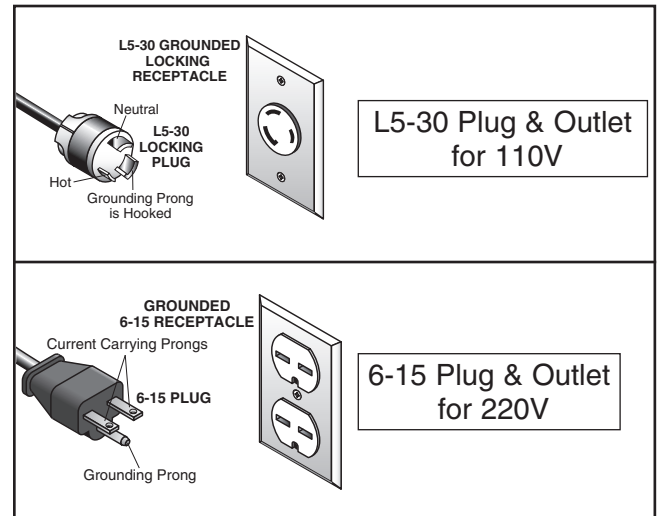

Figure 2. Recommended plug types.

Extension Cords

Using extension cords may reduce the life of the motor. Instead, place the machine near a power source. If you must use an extension cord:

- For 110V, use at least a 10 gauge cord that does not exceed 50 feet in length.
- For 220V, use at least a 14 gauge cord that does not exceed 50 feet in length.
- The extension cord must have a ground wire and plug pin.



Rewiring to 110V

The Model G0643 can be converted for 110V operation. This conversion job consists of disconnecting the machine from the power source, replacing the electrical box, replacing the **ON** button/lamp, and rewiring the motor for 110V operation.

The necessary electrical box and **ON** button/lamp for this procedure is the Model G0643 110V Conversion Kit (Part No. P0643222), and can be purchased by calling Grizzly Customer Service at (800) 523-4777.

All wiring changes must be inspected by a qualified electrician before the boring machine is connected to the power source. If, at any time during this procedure you need help, call Grizzly Tech Support at (570) 546-9663.

To rewire the Model G0643 for 110V operation:

1. DISCONNECT THE BORING MACHINE FROM POWER!
2. Remove the electrical box and replace it with the one included in the 110V Conversion Kit. Refer to the **Electrical Box Wiring Diagram** on **Page 32** for a detailed connection illustration.

3. Verify that the amperage setting on the thermal overload relay is set at 20 amps (see **Figure 3**).

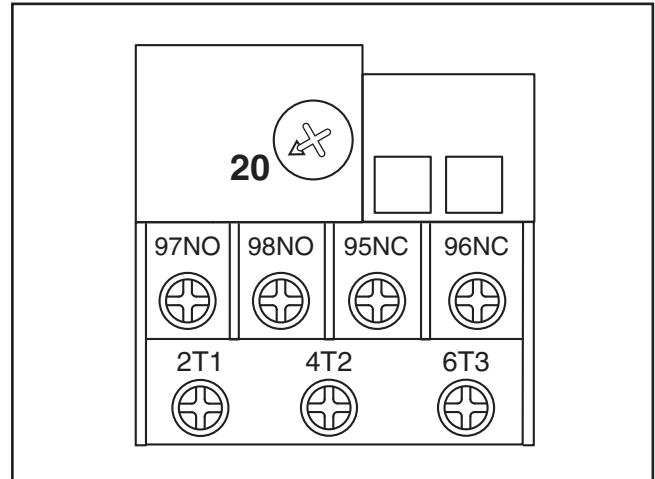

Figure 3. 110V thermal overload relay set at 10 amps.

4. Open the control panel cover and remove the **ON** button/lamp. Replace it with the one included in the 110V conversion kit.
5. Rewire the motor for 110V operation as shown on the diagram located inside the motor junction box, and close the control panel cover.

Note: *The **Motor, Control Panel, and Limit Switch Wiring Diagram** on **Page 33** was current at the time of printing, but always use the motor wiring diagram provided inside the motor junction box, as it will reflect any changes to the motor shipped with your machine.*



SECTION 3: SETUP

Setup Safety

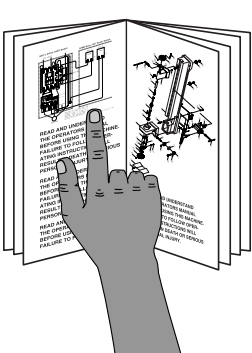

!WARNING
 This machine presents serious injury hazards to untrained users. Read through this entire manual to become familiar with the controls and operations before starting the machine!



!WARNING
 Wear safety glasses or a face shield during the entire setup process!



!WARNING
 This machine and its components are very heavy. Get lifting help or use power lifting equipment such as a fork lift to move heavy items.

Items Needed for Setup

The following items are needed to complete the setup process, but are not included with your machine:

Description	Qty
• Assistant (for moving machine).....	1
• Straightedge 4' (or longer)	1
• Accurate Level.....	1
• Standard Pneumatic Tool Oil	As Needed
• Face Shield (for each person).....	1
• Air Compressor (70 PSI)	1
• Air Hose (length as needed)	1
• Lifting Hook, Lifting Strap or Chain, Power Lifting Equipment (rated for 1000 lbs. or more)	1

Unpacking

This machine was carefully packaged for safe transport. When unpacking, separate all enclosed items from packaging materials and inspect them for shipping damage. ***If items are damaged, please call us immediately at (570) 546-9663.***

IMPORTANT: Save all packaging materials until you are completely satisfied with the machine and have resolved any issues between Grizzly or the shipping agent. ***You MUST have the original packaging to file a freight claim. It is also extremely helpful if you need to return your machine later.***



!WARNING
SUFFOCATION HAZARD!
 Keep children and pets away from plastic bags or packing materials shipped with this machine. Discard immediately.



Inventory

The following is a description of the main components shipped with your machine. Lay the components out to inventory them.

Note: *If you can't find an item on this list, check the mounting location on the machine or examine the packaging materials carefully. Occasionally we pre-install certain components for shipping purposes.*

Inventory: (Figure 4)	Qty
A. Boring Machine (not shown).....	1
B. Longitudinal Fence Assembly (not shown).....	1
C. Hex Wrench Set 1.5, 2, 2.5, 3, 4, 5, 6, 8, & 10mm.....	1 Each
D. Combo Open-End Wrenches 8/10mm, 11/13mm, 17/19mm.....	1 Each
E. Hex Wrenches 2.5mm.....	2
F. Table.....	1
G. Hardware Bag (not shown).....	1
— Flat Hd Cap Screws M6-1 x 35.....	4
— Hex Nuts M6-1.....	4
— Flat Washers 6mm.....	4
— Set Screws M5.8 x 5.....	42

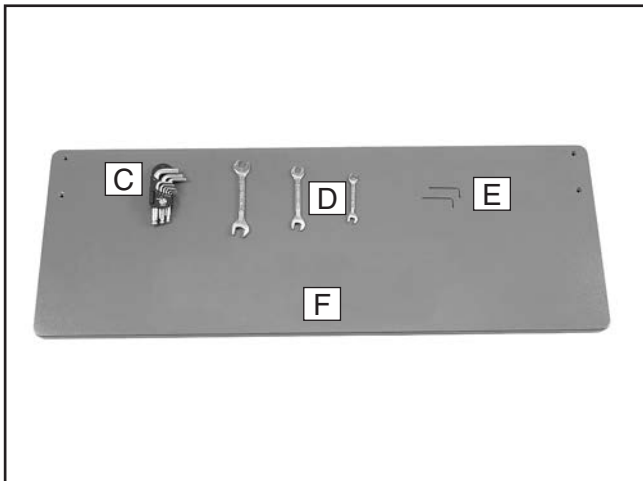

Figure 4. G0643 inventory.

If any nonproprietary parts are missing (e.g. a nut or a washer), we will gladly replace them; or for the sake of expediency, replacements can be obtained at your local hardware store.

Cleanup

The unpainted surfaces of your machine are coated with a heavy-duty rust preventative that prevents corrosion during shipment and storage. This rust preventative works extremely well, but it will take a little time to clean.

Be patient and do a thorough job cleaning your machine. The time you spend doing this now will give you a better appreciation for the proper care of your machine's unpainted surfaces.

There are many ways to remove this rust preventative, but the following steps work well in a wide variety of situations. Always follow the manufacturer's instructions with any cleaning product you use and make sure you work in a well-ventilated area to minimize exposure to toxic fumes.

Before cleaning, gather the following:

- Disposable rags
- Cleaner/degreaser (WD•40 works well)
- Safety glasses & disposable gloves
- Plastic paint scraper (optional)

Basic steps for removing rust preventative:

1. Put on safety glasses.
2. Coat the rust preventative with a liberal amount of cleaner/degreaser, then let it soak for 5–10 minutes.
3. Wipe off the surfaces. If your cleaner/degreaser is effective, the rust preventative will wipe off easily. If you have a plastic paint scraper, scrape off as much as you can first, then wipe off the rest with the rag.
4. Repeat **Steps 2–3** as necessary until clean, then coat all unpainted surfaces with a quality metal protectant to prevent rust.

NOTICE

Avoid chlorine-based solvents, such as acetone or brake parts cleaner, that may damage painted surfaces.



Site Considerations

Floor Load

Refer to the **Machine Data Sheet** on **Page 3** for the weight and footprint specifications of your machine. Some residential floors may require additional reinforcement to support both the machine and operator.

Placement Location

Consider existing and anticipated needs, size of material to be processed through each machine, and space for auxiliary stands, work tables or other machinery when establishing a location for your new machine. See **Figure 5** for the minimum working clearances.

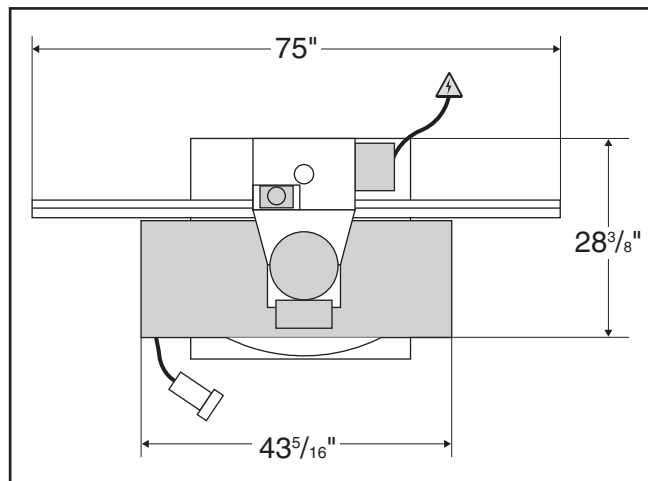
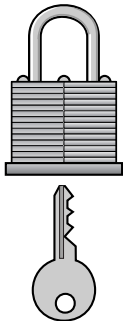

Figure 5. Minimum working clearances.

	<p>CAUTION</p> <p>Children and visitors may be seriously injured if unsupervised around this machine. Lock entrances to the shop or disable start switch or power connection to prevent unsupervised use.</p>
---	--

Mounting to Shop Floor

Although not required, we recommend that you mount your new machine to the floor. Because this is an optional step and floor materials may vary, floor mounting hardware is not included. Generally, you can either bolt your machine to the floor or mount it on machine mounts. Both options are described below. Whichever option you choose, it is necessary to level your machine with a precision level.

Bolting to Concrete Floors

Lag shield anchors with lag bolts and anchor studs (**Figure 6**) are two popular methods for anchoring an object to a concrete floor. We suggest you research the many options and methods for mounting your machine and choose the best that fits your specific application.

NOTICE

Anchor studs are stronger and more permanent alternatives to lag bolts; however, they will stick out of the floor, which may cause a tripping hazard if you decide to move your machine.

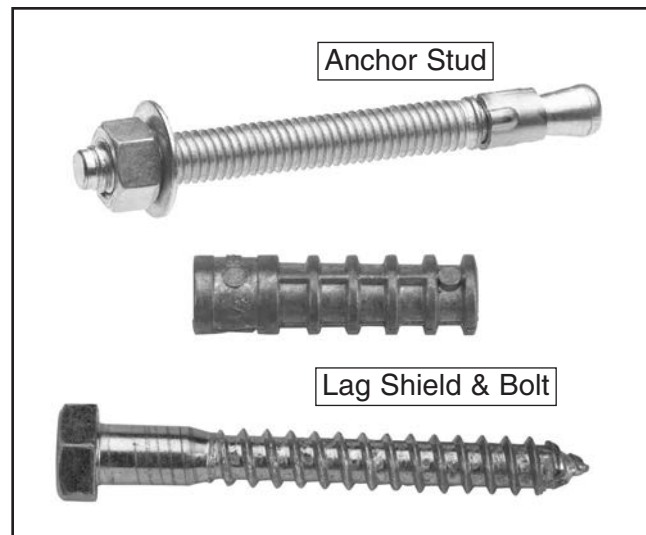

Figure 6. Typical fasteners for mounting to concrete floors.



Using Machine Mounts

Using machine mounts, shown in **Figure 7**, gives the advantage of fast leveling and vibration reduction. The large size of the foot pads distributes the weight of the machine to reduce strain on the floor.

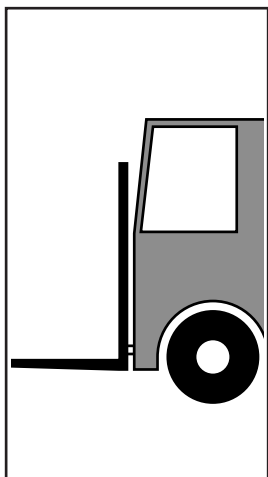

Figure 7. Machine mount example.

NOTICE

We strongly recommend securing your machine to the floor if it is hardwired to the power source. Consult with your electrician to ensure compliance with local codes.

Moving & Placing Base Unit

	<p>⚠ WARNING</p> <p>The Model G0643 is a heavy machine. Serious personal injury may occur if safe moving methods are not used. To be safe, get assistance and use power equipment rated for 1000 lbs. to move the shipping crate and remove the machine from the crate.</p>
---	--

To move your boring machine:

1. Prepare the permanent location for the boring machine. Refer to **CIRCUIT REQUIREMENTS** on **Page 8** and **Site Considerations** on **Page 12** for requirements.
2. Attach a safety hook and lifting strap or chain to the eye bolt on the top of the machine, then to the power lifting equipment (see **Figure 8**).



Figure 8. Boring machine attached to lifting equipment.

3. Unbolt the machine from the shipping crate.
4. With assistance and the use of the power lifting equipment, move the boring machine to the prepared location.
5. Make sure the top of the cabinet is level and mount the machine to the floor.

—If you are using permanent fasteners, use shims between the base and the floor to make sure the machine is level.

Note: To avoid cracking or warping the cast iron base, tighten the four corners down evenly.

—If you are using machine feet, adjust these until the machine is level.



Assembly

!WARNING

Serious personal injury could occur if you connect the machine to power before completing the setup process. **DO NOT** connect the machine to the power until instructed later in this manual.

After mounting the boring machine to your shop floor and providing the correct electrical connection, assemble the additional components.

To assemble your machine:

1. Slide the longitudinal fence assembly under the headstock as shown in **Figure 9**.

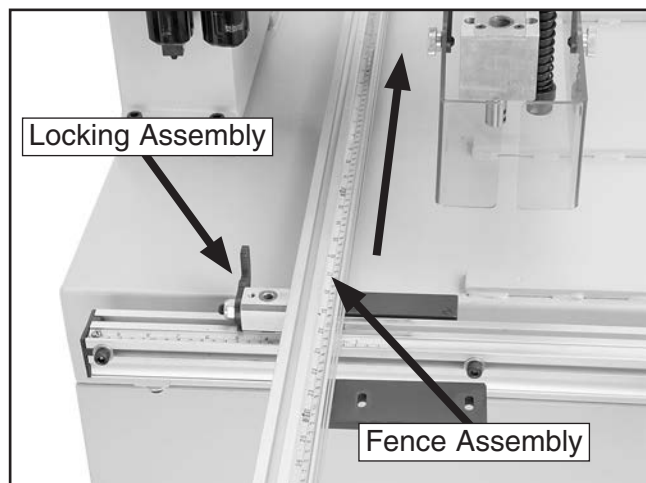

Figure 9. Longitudinal fence positioned for mounting to machine.

Note: Make sure the locking assembly of the longitudinal fence is facing the rear of the machine, as shown in **Figure 9**.

2. Thread the locking lever of the longitudinal fence into the hex nut that is located in the cross fence slot (see **Figure 10**).

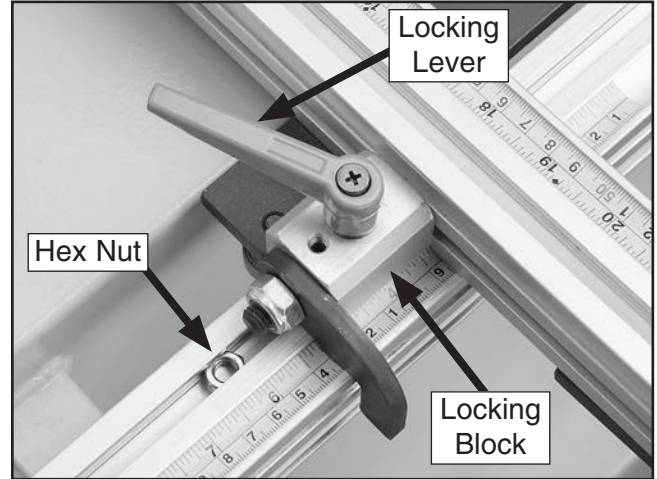

Figure 10. Longitudinal and cross fence attachment components.

3. Move the longitudinal fence up against the headstock column, and tighten both locking levers to hold it in place.
4. Position the table over the mounting flanges of the longitudinal fence, as shown in **Figure 11**.

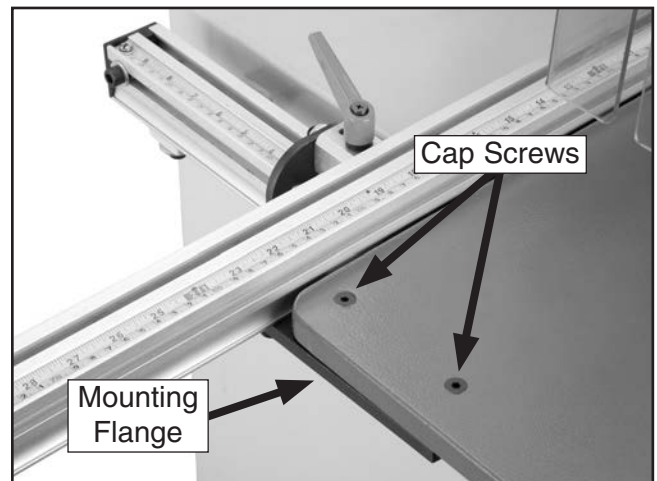

Figure 11. Table mounted to longitudinal fence.

5. Secure the table to the longitudinal fence with the four M6-1 x 35 flat head cap screws, flat washers, and hex nuts.



6. Clean any debris off the shafts of the indexing pins, apply a thin film of light machine oil to the entire length, and slide the compression spring onto the indexing pin shaft.
7. Slide the indexing pins into the holes at the ends of the boring head, as shown in **Figure 12**.

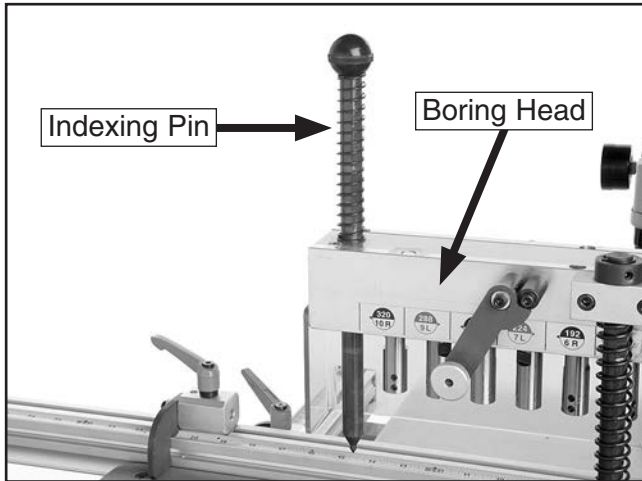

Figure 12. Indexing pin mounted in the boring head.

8. Remove the fill plug on top of the air lubricator unit (see **Figure 13**), and fill the oil reservoir with standard pneumatic tool oil.

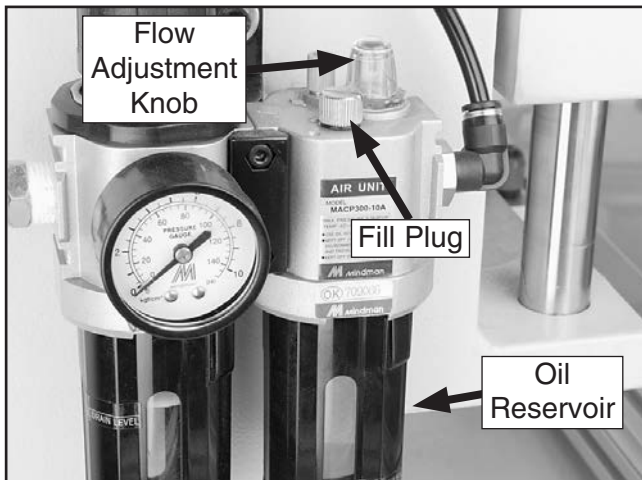

Figure 13. Air lubricator unit.

Note: Make sure the lubricator flow adjustment knob is open at least one full turn.

9. Attach the air compressor hose to the air inlet connection, and turn the air compressor on.

Note: The air compressor must provide at least 70 PSI of air pressure.

10. Adjust the air pressure on the air regulator by pulling up on the regulator adjustment knob (see **Figure 14**), and turning it so that the air pressure gauge reads 70 PSI.

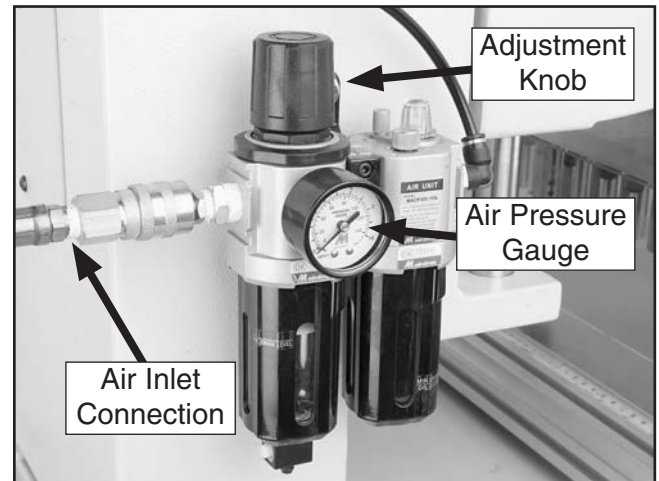

Figure 14. Air regulator unit.

11. Push the black adjustment knob down to lock the air pressure at that setting.
12. Clear away all tools and materials used for setup and assembly, then proceed to the **Test Run** on the next page.



Test Run

Once the setup and assembly are complete, test run your machine to make sure it runs properly.

If, during the test run, you cannot easily locate the source of an unusual noise or vibration, stop using the machine immediately, then review the **Troubleshooting** on **Page 26**.

If you still cannot remedy a problem, contact our Tech Support at (570) 546-9663 for assistance.

To test run the machine:

1. Read and follow the safety instructions at the beginning of the manual, and make sure the machine is setup properly.
2. Make sure all tools and objects used during set up are cleared away from the machine.
3. If there are boring bits installed in the machine, remove them.
4. Make sure the boring head guards are in place and are free to move up as the boring head comes down.
5. Make sure the air pressure dial on the air regulator reads 70 PSI.
6. Ensure the machine is lubricated (refer to **Lubrication** on **Page 23**).
7. Set the depth control to 0.50" (refer to **Adjusting Drilling Depth** on **Page 19** for detailing instructions).
8. Connect the machine to the power source.
9. Push the Emergency Stop button in, then twist it clockwise so it pops out. When this button pops out, the switch is reset and ready for operation (see **Figure 15**).



Figure 15. Resetting the switch.

10. Turn the machine **ON** by pushing the power button in—the green lamp on that button should light.
11. Press down on the foot switch—the boring head should come down and the boring chucks should begin to turn.
12. Listen to and watch for abnormal noises or actions. The machine should run smoothly with little or no vibration or rubbing noises.

—Strange or unusual noises should be investigated and corrected before operating the machine further. Always disconnect the machine from power when investigating or correcting potential problems.
13. Lift your foot from the foot switch, and turn the machine **OFF** by pressing the Emergency Stop button in.
14. With the power to the machine turned **OFF**, press the foot switch—the boring head should come down but the boring chucks should NOT turn.
15. If there were no problems during this **Test Run**, the boring machine is ready for operation.



SECTION 4: OPERATIONS

Operation Safety

!WARNING

Damage to your eyes and lungs could result from using this machine without proper protective gear. Always wear safety glasses or a face shield, and a respirator when operating this machine.

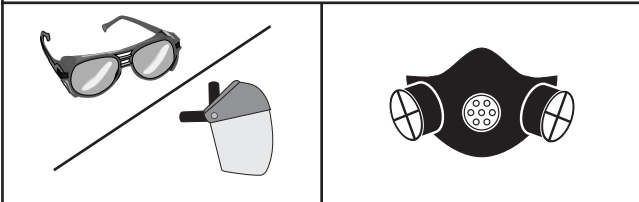

!WARNING

Loose hair and clothing could get caught in machinery and cause serious personal injury. Keep loose clothing and long hair away from moving machinery.



NOTICE

If you have never used this type of machine or equipment before, WE STRONGLY RECOMMEND that you read books, trade magazines, or get formal training before beginning any projects. Regardless of the content in this section, Grizzly Industrial will not be held liable for accidents caused by lack of training.

Installing Boring Bits

The Model G0643 boring machine accepts boring bits with the following specifications:

Total Quantity	21
Total Left Rotating	10
Total Right Rotating.....	11
Shank Diameter.....	10mm

Standard boring bits have a flat surface on the shank (see **Figure 16**), and an adjusting screw inside for height alignment.

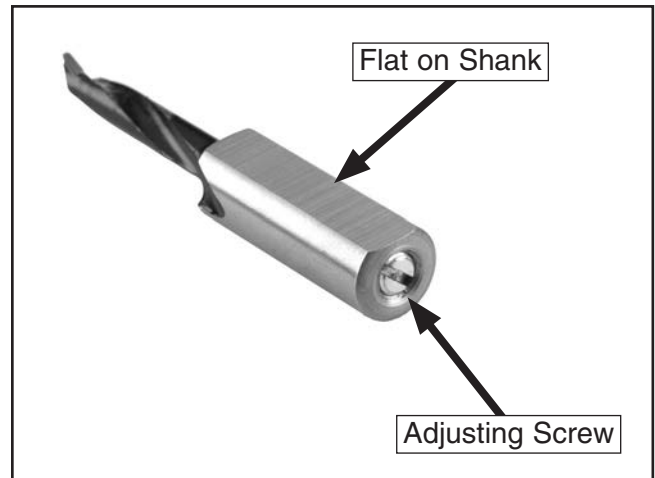

Figure 16. Standard boring bit.

To install boring bits:

1. DISCONNECT THE BORING MACHINE FROM POWER!
2. Unscrew the two knurled knobs and remove the front see-through guard from the boring head.



Note: Make sure the design of the boring bit to be installed matches the rotation direction of the chuck as shown by the information circle on the boring head above the chuck.

For example, in **Figure 17**, the left most chuck will rotate to the right, as viewed from above the chuck. This is shown by the letter "R" in the information circle. The boring bit will also be 320mm on center from the middle or number "0" boring bit, as shown by the number in the top of the information circle.

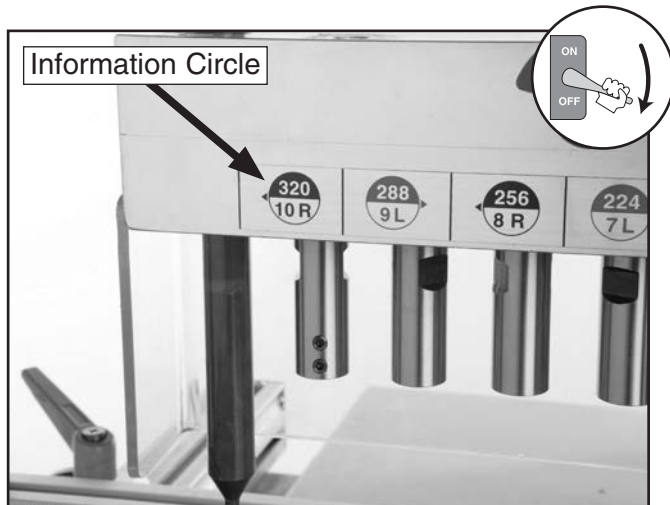

Figure 17. Boring chuck information circle on boring head.

⚠ CAUTION

Boring bits are sharp and can cut your hands. Protect yourself by using a shop rag to handle the bits for removal or installation.

3. Align the flat shank of the bit with the chuck and insert the bit completely into the chuck.

Note: Generally, slight differences of drilling depth from one bit to another is acceptable. However, if the drilling depth across all boring bits is required to be precise for your operation, see **Aligning Boring Bit Height on Page 30**.

4. Use a 2.5mm hex wrench to firmly tighten two M5-.8 x 5 set screws into the chuck (see **Figure 18**) and against the flat shank of the boring bit.

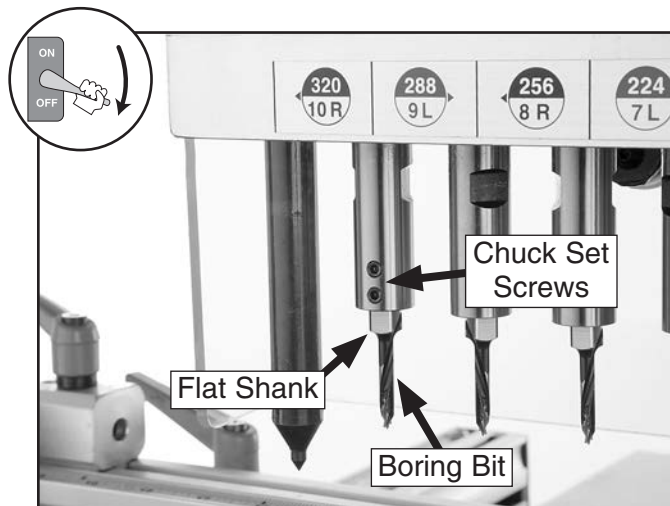

Figure 18. Boring bit installed.

5. Repeat **Steps 3–4** for any other bits to be installed.
6. Replace the front boring head guard.

Adjusting Downfeed Speed

The speed that the boring head lowers can be adjusted by turning the downfeed speed adjustment knob (see **Figure 19**). Experiment with different settings to determine the correct speed for your operation.



Figure 19. Downfeed speed adjustment knob.



Adjusting Drilling Depth

The drilling depth is precisely adjusted by using the depth control on top of the headstock column (see **Figure 20**). The depth control window shows the drilling depth in inches, with the last two digits as decimals.

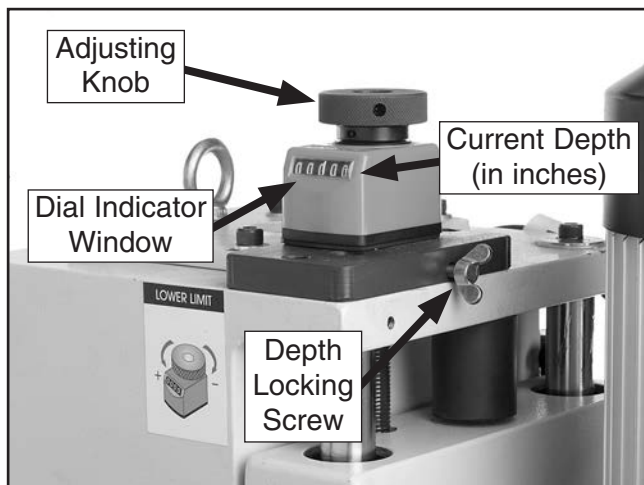

Figure 20. Boring bit depth control.

To adjust the drilling depth of the boring bits:

1. Loosen the depth locking screw shown in **Figure 20**.
2. Rotate the adjusting knob to bring the depth control to "0".
3. Calculate the drilling depth by using the following formula:

$A + B - C = \text{Drilling Depth}$

A = The distance from the bottom of the boring bit to the workpiece.

B = The desired depth of the hole to be drilled.

C = $\frac{1}{4}$ ", the distance the boring head lowers in addition to the setting of the depth control.

Note: Use the following case and **Figure 21** for an example of calculating drilling depth.

In this example, the distance from the bottom of the boring bit to the workpiece is $2\frac{1}{4}$ " (**A**), and the depth of the desired hole in the workpiece is $\frac{1}{2}$ " (**B**). Thus, the drilling depth is $2\frac{1}{2}$ ".

Calculation: $2\frac{1}{4}" + \frac{1}{2}" - \frac{1}{4}" = 2\frac{1}{2}"$

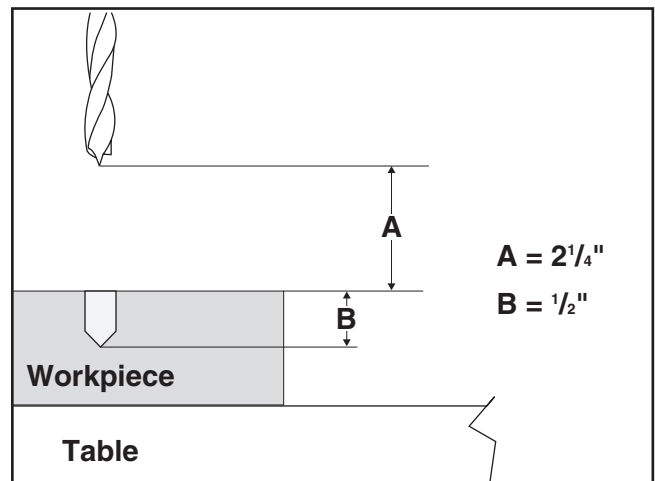

Figure 21. Example of calculating drilling depth.

4. Convert any fraction of the calculated drilling depth to a 2-place decimal ($\frac{1}{2}$ " in the above example is converted to 0.50").
 5. Set the depth control to the calculated drilling depth and re-tighten the depth locking screw to secure the setting.
- Note:** In the above example, the depth control would be set so that 2.50 would show in the dial indicator window.
6. Test the drilling depth setting on a scrap piece of stock that is the same thickness as your workpiece. Fine tune the depth control setting until you are satisfied with the drilling depth.

NOTICE

This line boring machine is designed to drill only wood products. Drilling any other material may damage the machine and will void the warranty.



Adjusting Hold-down Height

The hold-downs must firmly hold the workpiece during the boring operation, and are adjustable to accommodate the thickness of your stock.

To adjust the height of the workpiece hold-downs:

1. DISCONNECT THE BORING MACHINE FROM POWER!
2. Loosen the locking collar set screw so that the collar moves freely on the hold-down shaft (see **Figure 22**).

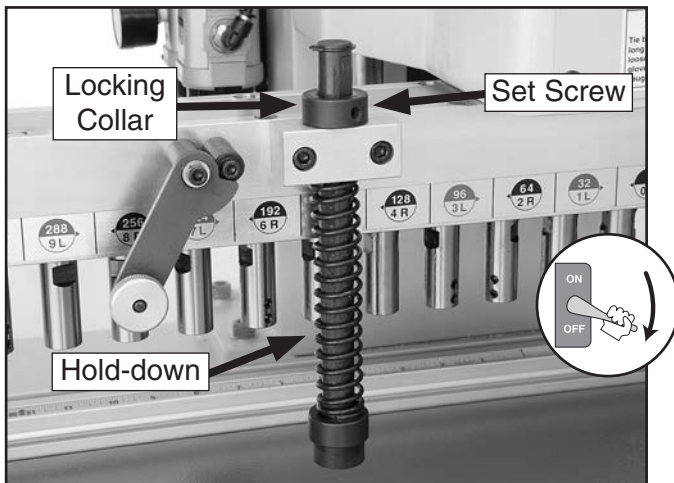

Figure 22. Workpiece hold-down (front boring head guard removed for photo clarity).

3. Lift the hold-down up until the bottom is just slightly higher than your workpiece when the boring head assembly is in the upper position, then re-tighten the locking collar set screw to secure the setting.

NOTICE

Make sure the hold-downs exert enough pressure to keep the workpiece in place against the rotational force of the boring bits. Otherwise, the workpiece may move during the boring operation, resulting in a drilling line that is out of alignment.

Positioning the Workpiece

The workpiece is positioned along the longitudinal and cross paths to align the boring bits with the desired line of drilling.

To position the workpiece for drilling:

1. Turn the power to the machine **OFF** by pressing the EMERGENCY STOP button in.
2. Unlock the longitudinal fence and move it along the cross fences to reach the correct distance from the boring bits along its entire length, then use the locking levers to secure it in place.

Note: The distance from the longitudinal fence to the boring bit centers can be measured on the cross fence scale, as shown in **Figure 23**.



Figure 23. Distance of 4" of the longitudinal fence from boring bit centers, as read on the cross fence scale.

NOTICE

If both ends of the longitudinal fence are not the same distance from the boring bit centers, the drilled holes will not line up correctly. Make sure that both ends of the longitudinal fence are the same distance from the boring bit centers before you tighten the locking levers.



3. Determine the drilling starting point of your workpiece and position it under the boring head and firmly against the longitudinal fence.
4. Use the longitudinal fence stops (**Figure 24**) to preserve the starting point when drilling workpieces that are the same length.

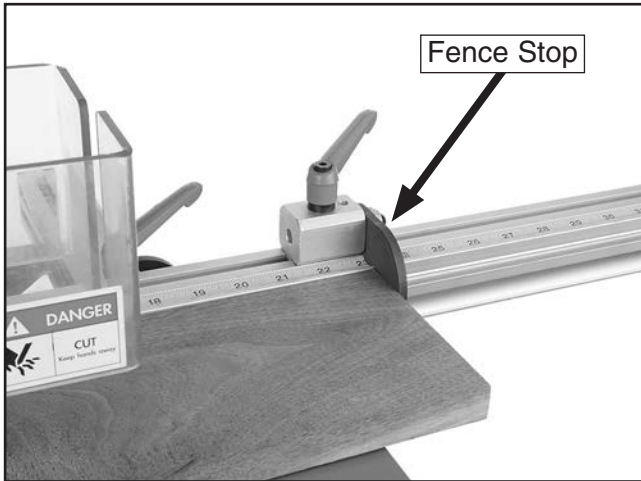

Figure 24. Longitudinal fence stop.

5. If you need to drill more than 21 holes, push the indexing pin into the last previously drilled hole to position the workpiece, as shown in **Figure 25**.

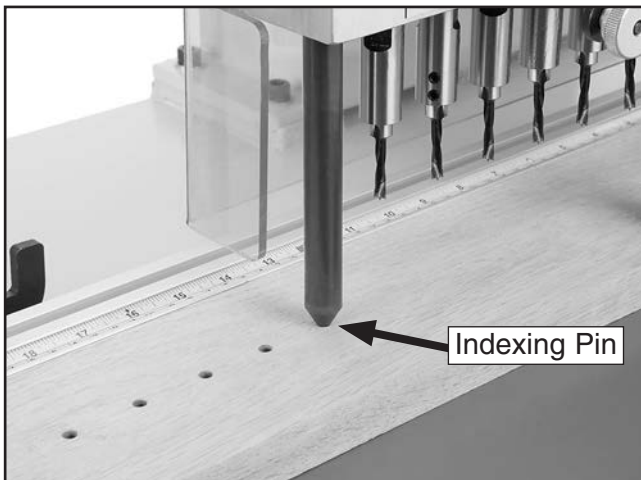

Figure 25. Using the indexing pin to position workpiece for additional drilling (front boring head guard removed for photo clarity).

Drilling Overview

Before beginning the boring operation, follow these instructions:

- Make sure the boring head guards are in place and are free to move up as the boring head comes down.
- Adjust the air pressure on the air regulator to 70 PSI.
- Lock the table in the correct position.
- Set the depth control to the calculated drilling depth.
- Make sure that your workpiece is firmly against the longitudinal fence, and use push sticks to hold it in position.

When ready, press the foot switch to lower the boring head and start the boring bits rotating. When the drilling is complete, lift your foot from the foot switch—the rotation of the boring bits will stop and the boring head will lift to the upper position.

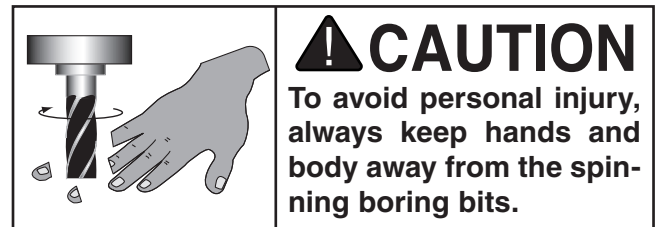

SECTION 5: ACCESSORIES

G8982—Shop Fox Roller Table

Use this versatile roller table wherever you need extra workpiece support. Features all steel welded construction and measures 19" x 65" long. Comes with 9 ball bearing rollers and has four independently adjustable legs for any leveling requirement. Adjustable in height from 26³/₈" to 44¹/₈".



Figure 26. G8982 Shop Fox roller table.

H3308—Shop Fox Push Stick

Measuring 13¹/₂" overall, this push stick allows the operator to keep their hands at a safe distance away from the blade or cutter.

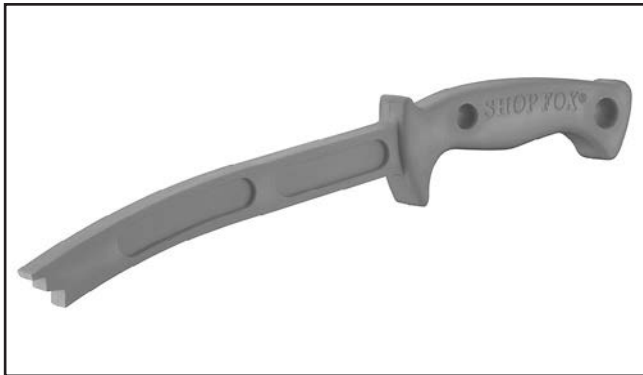

Figure 27. H3308 Shop Fox Push Stick.

H3361—Clear Shelf Supports

H3362—White Shelf Supports

H3363—Brown Shelf Supports

These Shelf Supports are ideal for easy to adjust shelving. Available in clear, white, and brown. Pins measure 1³/₆₄" (5mm) diameter by 5⁵/₁₆" long. 12 per pack.

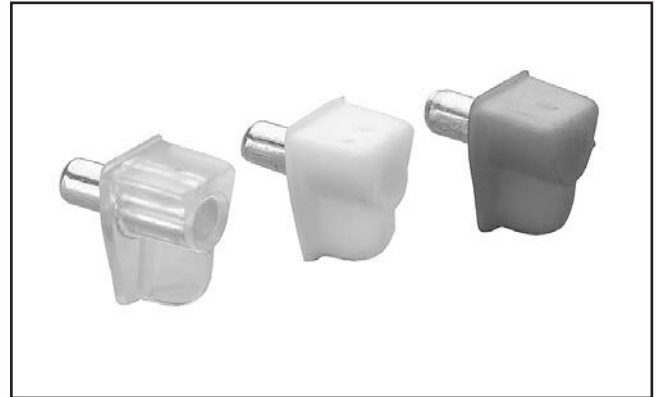

Figure 28. Shelf Supports.

H1324—2" Quick-Grip® Handi Clamp

H3896—4" Quick-Grip® Handi Clamp

Squeeze to adjust and lock. Click to release. Use anywhere you need an extra hand.

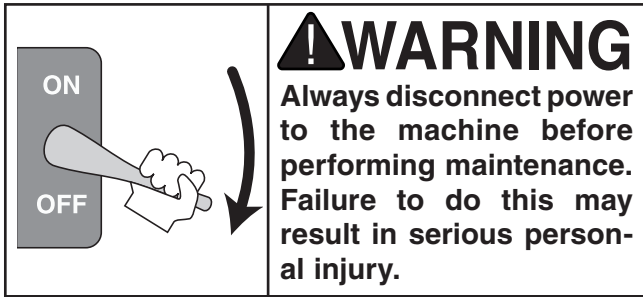

Figure 29. Quick-Grip® Handi Clamp.

Call 1-800-523-4777 To Order



SECTION 6: MAINTENANCE



Schedule

For optimum performance from your machine, follow this maintenance schedule and refer to any specific instructions given in this section.

Daily Maintenance:

- Clean table, boring head, and motor of sawdust and resin.
- Check for loose mounting bolts.
- Check for worn or damaged boring bits.
- Check pneumatic oil reservoir level.
- Empty air filter reservoir.
- Check for worn or damaged wires.
- Check for any other unsafe condition.

Weekly Maintenance:

- Clean and lubricate headstock ways and leadscrew.

Monthly Maintenance:

- Lubricate boring head.

Cleaning

Cleaning the Model G0643 is relatively easy. Vacuum excess wood chips and sawdust, and wipe off the remaining dust with a dry cloth. If any resin has built up, use a resin dissolving cleaner to remove it. Treat all unpainted cast iron and steel with a non-staining lubricant after cleaning.

Lubrication

The Model G0643 has four points of lubrication: 1) the boring head, 2) the headstock slide shafts, 3) the headstock leadscrew, and 4) the air lubricator.

To lubricate the boring head:

1. DISCONNECT THE BORING MACHINE FROM POWER!
2. Use a grease gun to inject two or three pumps of multi-purpose grease into each of the two grease fittings, located on the boring head rear face (see **Figure 30**).

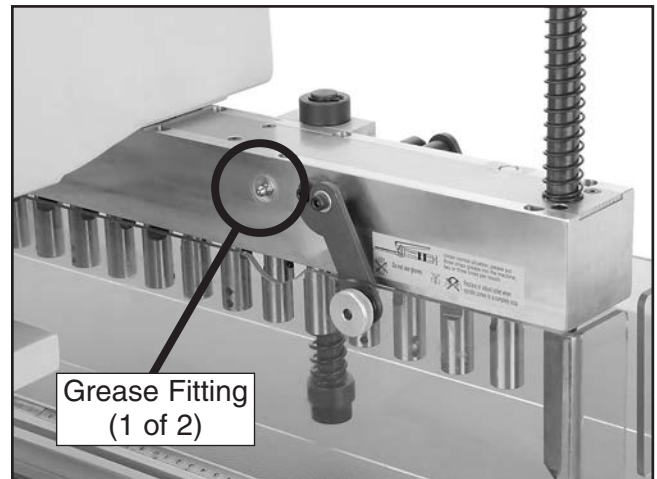

Figure 30. Boring head grease fitting (1 of 2 shown)



To lubricate the headstock slide shafts and leadscrew:

1. DISCONNECT THE BORING MACHINE FROM POWER!
2. Set the depth control to "0".
3. Clean sawdust and debris from the visible sections of the headstock slide shafts and leadscrew (see **Figures 31–32**).

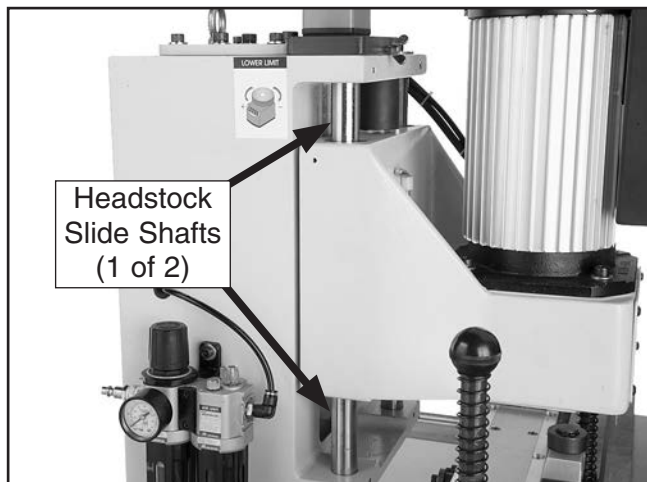

Figure 31. Headstock slide shafts (1 of 2 shown).



Figure 32. Headstock leadscrew.

NOTICE

Failure to perform proper lubrication maintenance on this machine will lead to premature wear of the moving parts, and will void the warranty.

4. Apply a thin coat of light machine oil to the slide shafts and leadscrew.
5. With the power still disconnected, set the depth control to 0.50" and use the foot pedal to move the boring head up and down a few times to evenly distribute the lubricant along the slide shafts and leadscrew.



To fill the pneumatic oil reservoir:

1. Remove the fill plug from the top of the air lubricator unit (see **Figure 33**).

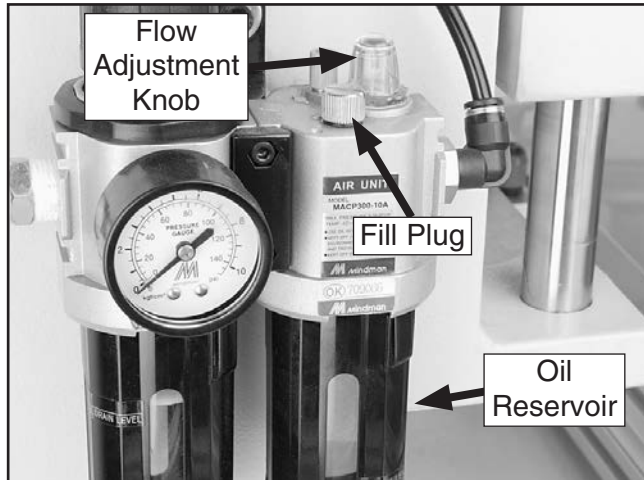

Figure 33. Air lubricator unit maintenance components.

2. Fill the oil reservoir with standard pneumatic oil, and replace the fill plug.
3. Make sure the flow adjustment knob is open at least one full turn.

Air Filter Reservoir

The air regulator unit filters any water vapor from the incoming air supply, and should be emptied daily.

To empty the air filter reservoir of water:

1. Make sure that there is 70 PSI of air pressure connected to the air regulator.
2. To release the collected water from the reservoir, carefully press the release valve at the bottom of the reservoir, as shown in **Figure 34**.



Figure 34. Release water from the air filter reservoir.

Note: When the release valve is pressed, air will also be expelled along with the collected water from the reservoir.



SECTION 7: SERVICE

Review the troubleshooting and procedures in this section if a problem develops with your machine. If you need replacement parts or additional help with a procedure, call our Technical Support. **Note:** *Please gather the serial number and manufacture date of your machine before calling.*

Troubleshooting

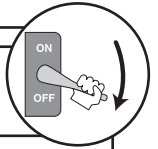

Motor & Electrical

Symptom	Possible Cause	Possible Solution
Machine does not start or a breaker trips.	<ol style="list-style-type: none"> Headstock safety limit switch is not properly adjusted or is at fault. Fuse has blown. Plug/receptacle is at fault or wired incorrectly. Start capacitor is at fault. Emergency stop push-button is engaged/faulty. Motor connection wired incorrectly. Wall fuse/circuit breaker is blown/tripped. Thermal overload relay has tripped. Contactors not getting energized/has burnt contacts. Power supply switched OFF or is at fault. Wiring is open/has high resistance. Power ON button is at fault. Centrifugal Switch is at fault. Motor is at fault. 	<ol style="list-style-type: none"> Re-adjust the headstock safety limit switch (see Page 28), or replace. Correct short/replace fuse inside electrical box. Test for good contacts; correct the wiring. Test/replace if faulty. Rotate clockwise slightly until it pops out/replace it. Correct motor wiring connections. Ensure circuit size is suitable for this machine; replace weak breaker. Turn cut-out dial to increase working amps and push the reset pin. Replace if tripped multiple times (weak relay). Test for power on all legs and contactor operation. Replace unit if faulty. Ensure power supply is switched on; ensure power supply has the correct voltage. Check for broken wires or disconnected/corroded connections, and repair/replace as necessary. Replace faulty ON button switch. Adjust/replace the centrifugal switch if available. Test/repair/replace.
Machine has vibration or noisy operation.	<ol style="list-style-type: none"> Motor or component is loose. Motor mount loose/broken. Machine is incorrectly mounted or sits unevenly on floor. Motor fan is rubbing on fan cover. Motor/boring head bearings are at fault. Centrifugal switch is faulty. Chuck or boring bit is at fault. 	<ol style="list-style-type: none"> Inspect/replace stripped or damaged bolts/nuts, and re-tighten with thread locking fluid. Tighten/replace. Tighten/replace anchor studs in floor; relocate/shim machine. Replace dented fan cover; replace loose/damaged fan. Test by rotating shaft; rotational grinding/loose shaft requires bearing replacement. Replace. Replace out-of-round chuck, dull, or bent boring bit.



Motor & Electrical (continued)

Symptom	Possible Cause	Possible Solution
Machine stalls or is overloaded.	<ol style="list-style-type: none"> 1. Workpiece material is not suitable for this machine. 2. Run capacitor is at fault. 3. Motor connection is wired incorrectly. 4. Plug/receptacle is at fault. 5. Motor/boring head bearings are at fault. 6. Machine undersized for task. 7. Motor has overheated. 8. Contactor not getting energized or has poor contacts. 9. Motor is at fault. 10. Centrifugal switch is at fault. 	<ol style="list-style-type: none"> 1. Only drill wood products; make sure moisture content is below 20% and there are no foreign materials in the workpiece. 2. Test/repair/replace. 3. Correct motor wiring connections. 4. Test for good contacts; correct the wiring. 5. Test by rotating shaft; rotational grinding/loose shaft requires bearing replacement. 6. Use sharp bits/reduce downfeed rate. 7. Clean off motor, let cool, and reduce workload. 8. Test for power on all legs and contactor operation. Replace if faulty. 9. Test/repair/replace. 10. Adjust/replace centrifugal switch if available.

Operation

Symptom	Possible Cause	Possible Solution
Machine slows when operating.	<ol style="list-style-type: none"> 1. Applying too much pressure to workpiece. 2. Boring bits are dull. 	<ol style="list-style-type: none"> 1. Slow the downfeed rate. 2. Replace boring bits.
Holes do not line up correctly.	<ol style="list-style-type: none"> 1. Longitudinal fence is not parallel with the boring head. 2. Workpiece not kept firmly against longitudinal fence. 	<ol style="list-style-type: none"> 1. Make sure that both ends of the longitudinal fence are the same distance from the boring head/bit centers before tightening the locking levers. 2. Use push sticks to keep workpiece firmly against longitudinal fence during drilling operation.
Holes bored at an angle.	<ol style="list-style-type: none"> 1. Table is not parallel with boring head. 2. Chuck or boring bit is at fault. 	<ol style="list-style-type: none"> 1. Align table parallel to boring head (see Page 29). 2. Replace out-of-round chuck; replace/re-install boring bit.
Depth of holes are not equal.	<ol style="list-style-type: none"> 1. Table is not parallel with boring head. 2. Heights of boring bits are not aligned. 	<ol style="list-style-type: none"> 1. Align table parallel to boring head (see Page 29). 2. Align the height of boring bits (see Page 30).



Adjusting Headstock Limit Switch

The headstock limit switch is a safety mechanism that ensures the boring bits will not rotate unless the boring head is lowered to the workpiece.

This limit switch usually does not need adjustment. However, if the boring heads do not rotate when the foot switch is pressed, you may need to adjust the height of the limit switch relative to the headstock.

To adjust the headstock limit switch:

1. Set the depth control to "0".
2. Use a 5mm hex wrench to loosen the cap screws securing the limit switch (see **Figure 35**).

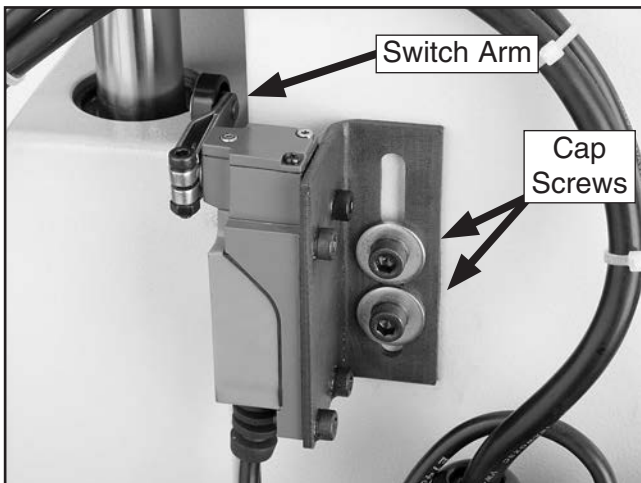

Figure 35. Headstock limit switch.



3. Adjust the limit switch position so that the switch arm lowers enough that the machine turns **ON**; then move the limit switch down until the switch arm is moved up and turns the machine **OFF**.
4. Re-tighten the limit switch cap screws.
5. Set the depth control to $\frac{1}{2}$ " (0.50" in the dial indicator window).
6. Test the limit switch position by pressing and releasing the foot switch, and make sure the machine turns **OFF** when the boring head raises up.

—If the machine does not turn **OFF** when the boring head is in the upper position, then repeat **Steps 1–4** until it does.



Adjusting Table Parallel to Boring Head

If the table is not parallel to the boring head, drilled holes will be at an angle or at different depths.

To check and adjust the table parallel to the boring head:

1. DISCONNECT THE BORING MACHINE FROM POWER!
2. Use a dial indicator or a planed piece of stock to measure the distance between the table and boring head at the four corners of the boring head (refer to the X's illustrated in **Figure 36**).

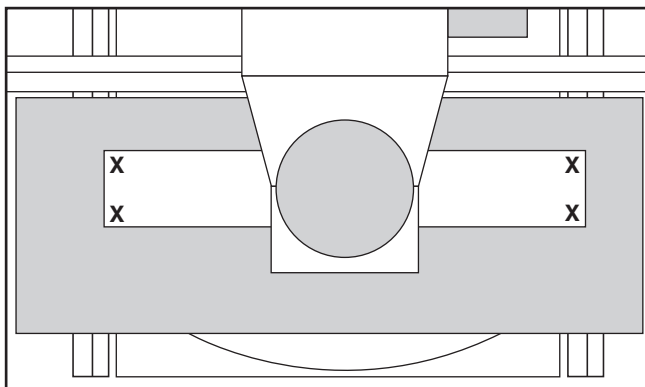

Figure 36. Measurement points (X's) for table and boring head parallelism (top view).

—If these distances are not equal, the table and boring head are not parallel to one another. Continue to **Step 3**.

—If these distances are equal, the table and boring head are parallel, and no further adjustments are necessary.

3. Loosen the cap screws that secure the cross fence (see **Figure 37**), and shim between the mounting bracket and the cross fence.

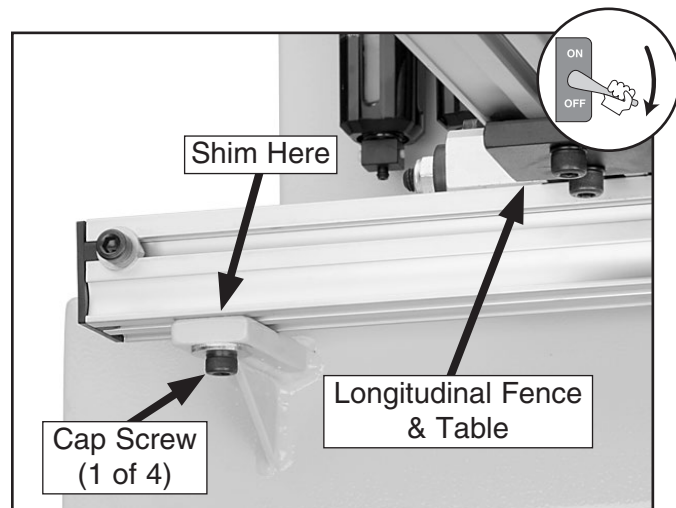

Figure 37. Adjusting table parallelism.

4. Re-tighten the cross fence cap screws, and re-check the parallelism of the table and boring head. Repeat this procedure if necessary.



Aligning Boring Bit Height

To ensure drilled holes are consistent in depth along the length of the workpiece, the height of all boring bits must be equal.

Note: *The table must be parallel to the boring head before aligning the boring bits. Refer to **Adjusting Table Parallel to Boring Head** on Page 29.*

To align boring bit height:

1. DISCONNECT THE BORING MACHINE FROM POWER!

CAUTION

Boring bits are sharp and can cut your hands. Protect yourself by using a shop rag to handle the bits during removal or installation.

2. Make sure that all boring bits are inserted fully into the chuck.

Note: *This can be done by loosening the two set screws that hold the bit into the chuck, and, while applying moderate upward pressure on the bit, re-tightening the set screws.*

3. Use a dial indicator or a planed piece of stock to determine if all boring bits are the same distance from the table.
4. The height of a boring bit can be adjusted by removing the bit from the chuck, turning the center screw of the bit (see **Figure 38**), then re-installing the bit into the chuck.

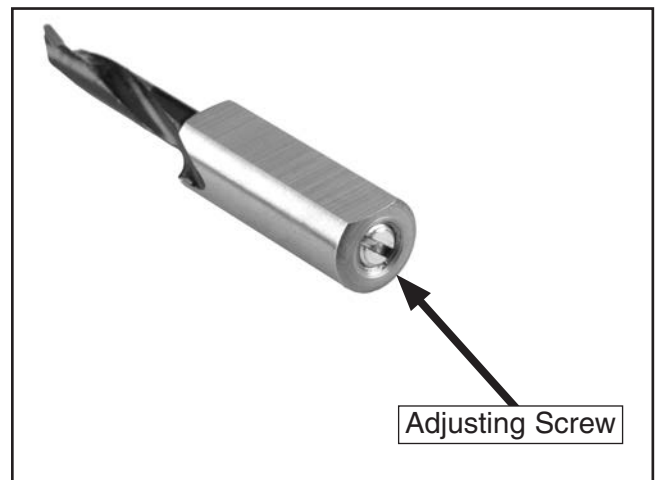

Figure 38. Boring bit height adjusting screw.

Note: *Threading the adjusting screw into the bit raises the working height of the boring bit.*



Electrical Components



Figure 39. Model G0643 electrical box (see **Page 32**).

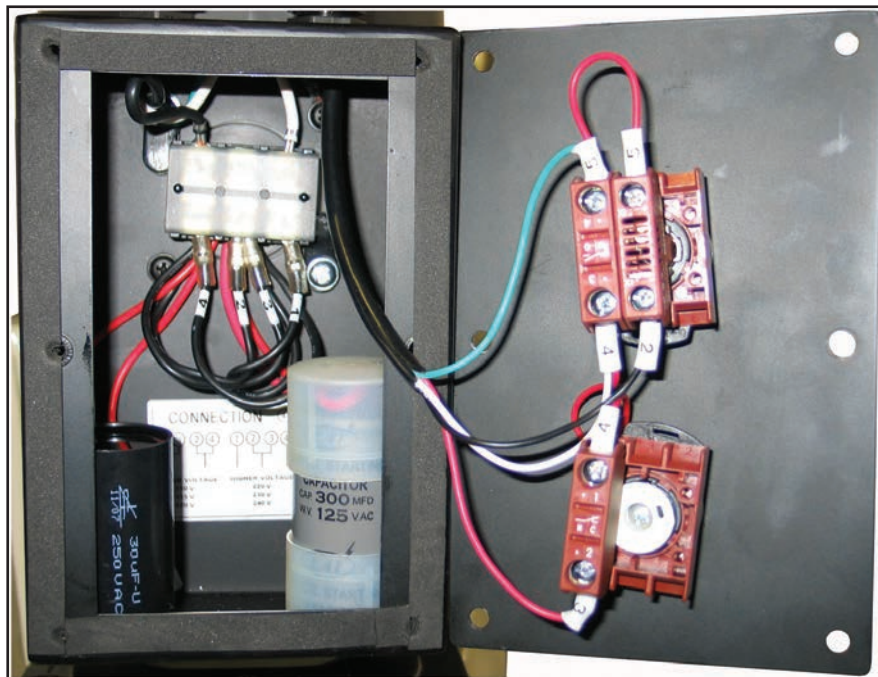
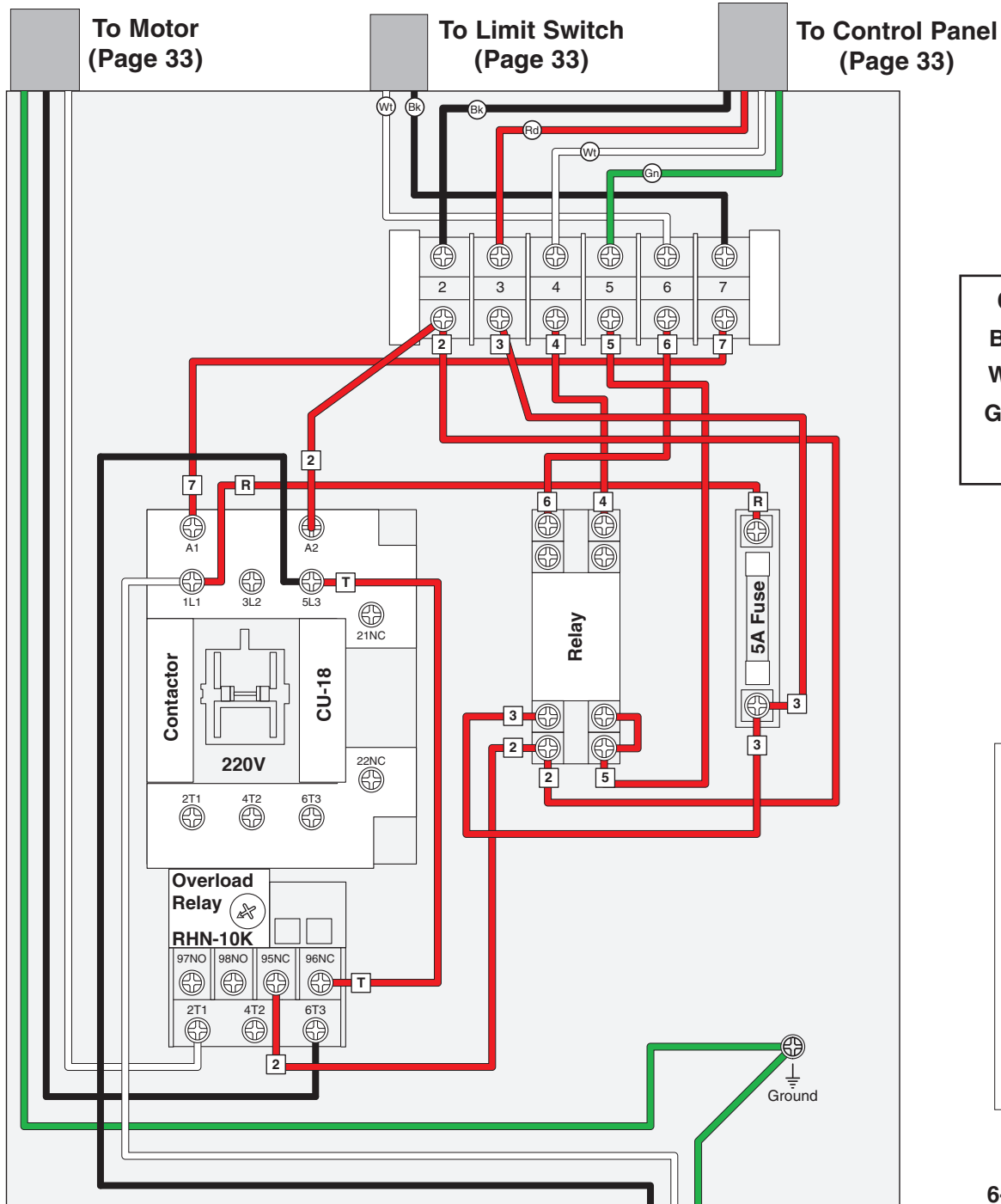

Figure 40. Model G0643 motor and control panel (see **Page 33**).



Model G0643 Electrical Box Wiring Diagram



COLOR KEY

- Black — Bk
- White — Wh
- Green — Gn
- Red — Rd

WARNING!
SHOCK HAZARD
Disconnect power before working on wiring!

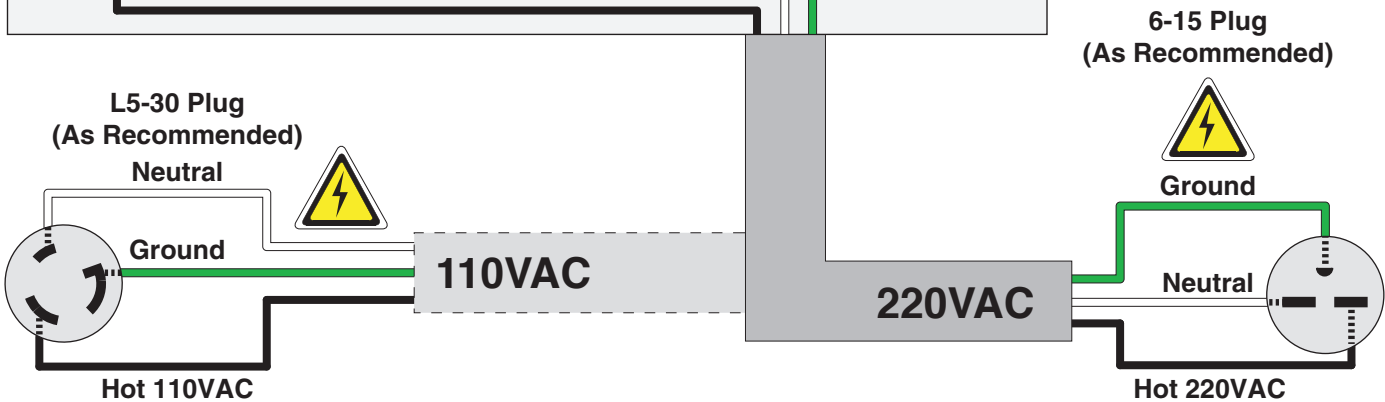

Model G0643 Motor, Control Panel & Limit Switch Wiring Diagram

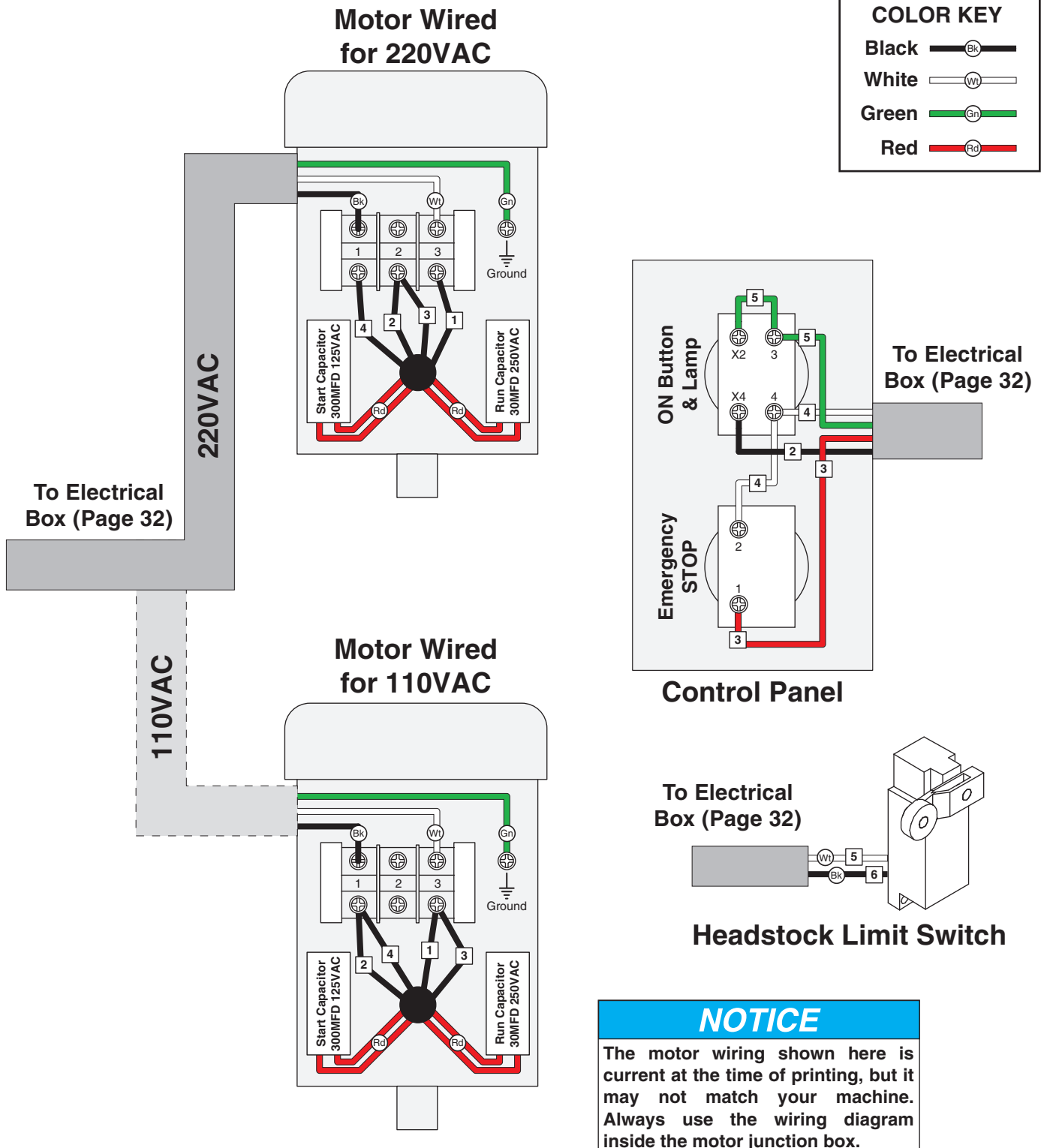

SECTION 8: PARTS

Column Breakdown

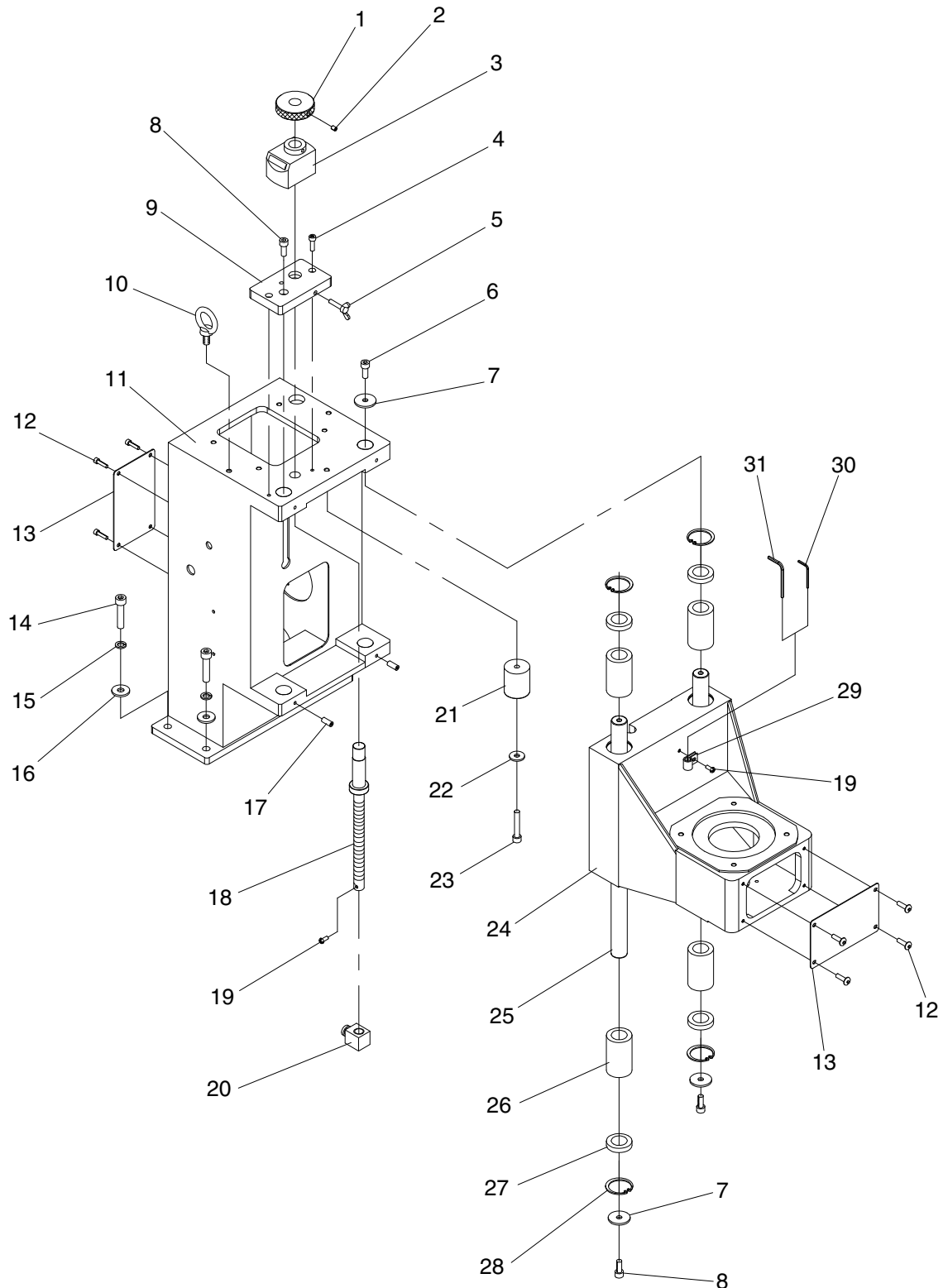

BUY PARTS ONLINE AT GRIZZLY.COM!
Scan QR code to visit our Parts Store.



Column Parts List

REF	PART #	DESCRIPTION
1	P0643001	KNURLED KNOB
2	P0643002	SET SCREW M6-1 X 10
3	P0643003	DEPTH CONTROL
4	P0643004	CAP SCREW M6-1 X 20
5	P0643005	WING SCREW M6-1 X 35
6	P0643006	CAP SCREW M8-1 X 16
7	P0643007	FLAT WASHER 8MM
8	P0643008	CAP SCREW M8-1.25 X 20
9	P0643009	DEPTH CONTROL MOUNT
10	P0643010	LIFTING EYE BOLT
11	P0643011	COLUMN
12	P0643012	CAP SCREW M5-.8 X 12
13	P0643013	COVER
14	P0643014	CAP SCREW M10-1.5 X 30
15	P0643015	LOCK WASHER 10MM
16	P0643016	FLAT WASHER 10MM

REF	PART #	DESCRIPTION
17	P0643017	SET SCREW M8-1.25 X 10
18	P0643018	HEADSTOCK LEAD SCREW
19	P0643019	PHLP HD SCR M5-.8 X 12
20	P0643020	DEPTH STOP
21	P0643021	BUMPER
22	P0643022	FLAT WASHER 8MM
23	P0643023	CAP SCREW M8-1.25 X 50
24	P0643024	HEADSTOCK
25	P0643025	HEADSTOCK WAY
26	P0643026	BUSHING
27	P0643027	SEAL
28	P0643028	INT RETAINING RING 40MM
29	P0643029	CABLE CLAMP
30	P0643030	HEX WRENCH 2.5MM
31	P0643031	HEX WRENCH 6MM



Air System Breakdown

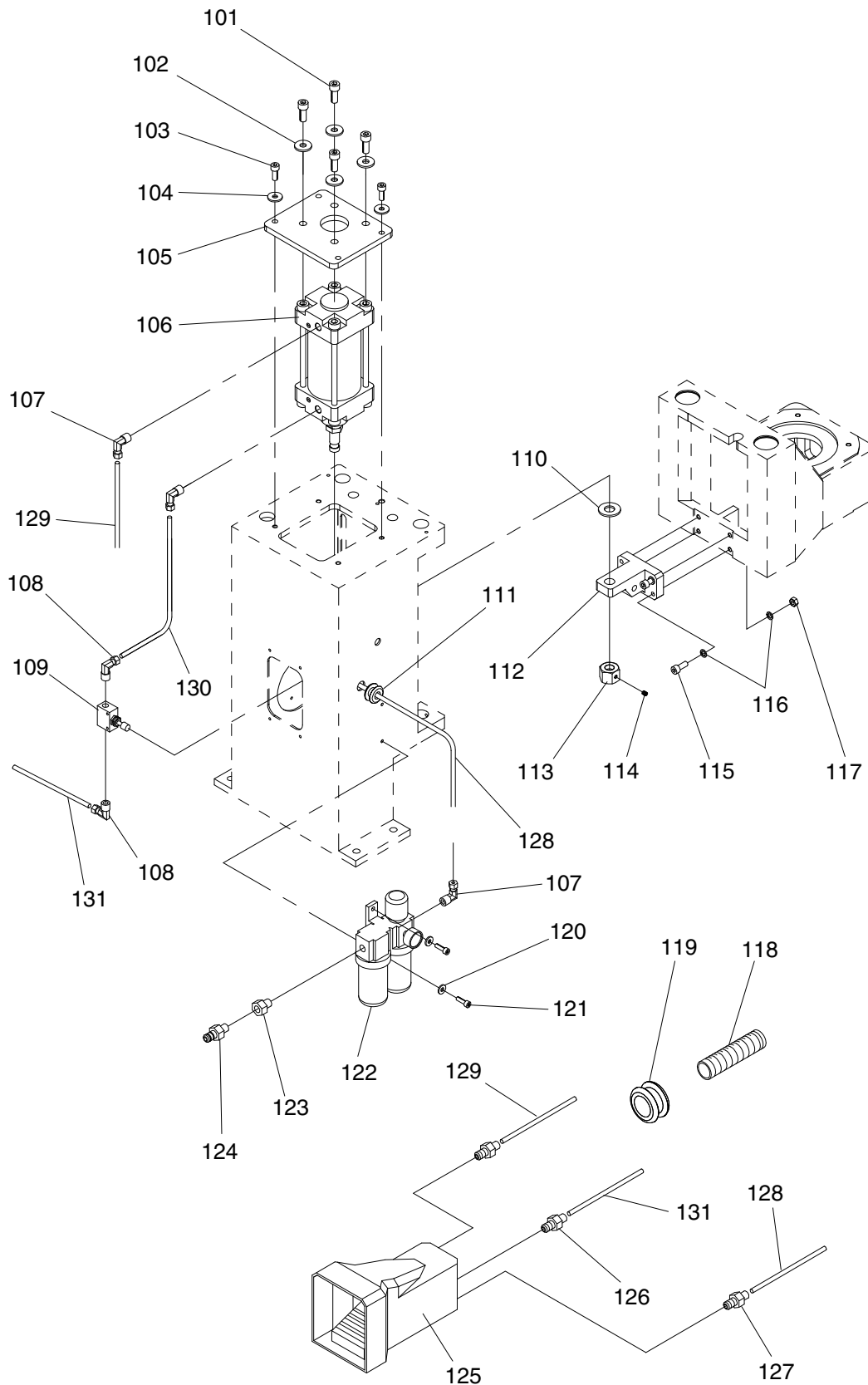

Air System Parts List

REF	PART #	DESCRIPTION
101	P0643101	CAP SCREW M10-1.5 X 35
102	P0643102	FLAT WASHER 10MM
103	P0643103	CAP SCREW M8-1.25 X 20
104	P0643104	FLAT WASHER 8MM
105	P0643105	AIR CYLINDER COVER
106	P0643106	AIR CYLINDER ASSY
107	P0643107	PIPE ELBOW MALE 3/8" X 8MM
108	P0643108	PIPE ELBOW MALE 3/8" X 6MM
109	P0643109	AIR PRESSURE VALVE
110	P0643110	FLAT WASHER 16MM
111	P0643111	RUBBER GROMMET
112	P0643112	HEADSTOCK MOUNT
113	P0643113	THREADED LOCK COLLAR
114	P0643114	SET SCREW M6-1 X 10
115	P0643115	CAP SCREW M8-1.25 X 40
116	P0643116	LOCK WASHER 8MM

REF	PART #	DESCRIPTION
117	P0643117	HEX NUT M8-1.25
118	P0643118	PU TUBE 1/2" X 2500MM
119	P0643119	RUBBER SLEEVE
120	P0643120	FLAT WASHER 6MM
121	P0643121	CAP SCREW M6-1 X 16
122	P0643122	AIR REGULATOR/LUBRICATOR ASSY
123	P0643123	PIPE REDUCER 3/8" X 1/4"
124	P0643124	AIR INLET CONNECTOR 1/4 NPT
125	P0643125	FOOT SWITCH ASSY
126	P0643126	PIPE UNION MALE 1/4" X 6MM
127	P0643127	PIPE UNION MALE 1/4" X 8MM
128	P0643128	PU TUBE 5 X 8 X 3150MM
129	P0643129	PU TUBE 5 X 8 X 3090MM
130	P0643130	PU TUBE 4 X 6 X 800MM
131	P0643131	PU TUBE 4 X 6 X 2950MM



Electrical System Parts List

REF	PART #	DESCRIPTION
201	P0643201	OFF BUTTON
202	P0643202	ON BUTTON W/ LAMP 220V
203	P0643203	SWITCH PANEL LABEL
204	P0643204	SWITCH PANEL
205	P0643205	RUBBER GASKET
206	P0643206	SWITCH BOX
207	P0643207	STRAIN RELIEF
208	P0643208	MOTOR 2HP 110/220V 1-PH
208-1	P0643208-1	MOTOR FAN COVER
208-2	P0643208-2	MOTOR FAN
208-3	P0643208-3	S CAPACITOR 300M 125V 1.38 X 2.75
208-4V2	P0643208-4V2	R CAPACITOR 30M 250V 1.5 X 2.38 V2.06.17
208-5	P0643208-5	TERMINAL BLOCK 3 POLE
209	P0643209	CAP SCREW M8-1.25 X 30
210	P0643210	FLAT WASHER 8MM
211	P0643211	PHLP HD SCR M5-.8 X 12
212	P0643212	CABLE CLAMP
213	P0643213	PLASTIC PLUG

REF	PART #	DESCRIPTION
214	P0643214	LIMIT SWITCH BRACKET
215	P0643215	CAP SCREW M5-.8 X 10
216	P0643216	FLAT WASHER 6MM
217	P0643217	CAP SCREW M6-1 X 16
218	P0643218	LIMIT SWITCH
219	P0643219	FLAT WASHER 5MM
220	P0643220	ELECTRICAL BOX 220V
220-1V2	P0643220-1V2	CONTACTOR TEC CN18 220V V2.05.13
220-2	P0643220-2	OL RELAY TEC RHN-10K 8.5-12.5
220-3	P0643220-3	RELAY 5A 220VAC
220-4	P0643220-4	FUSE HOLDER
220-5	P0643220-5	FUSE 5A
220-6	P0643220-6	TERMINAL BLOCK 6 POLE
221	P0643221	POWER CABLE
222	P0643222	110V CONVERSION KIT
223	P0643223	LIMIT SWITCH CABLE
224	P0643224	MOTOR POWER CABLE
225	P0643225	SWITCH BOX CABLE



Table Breakdown

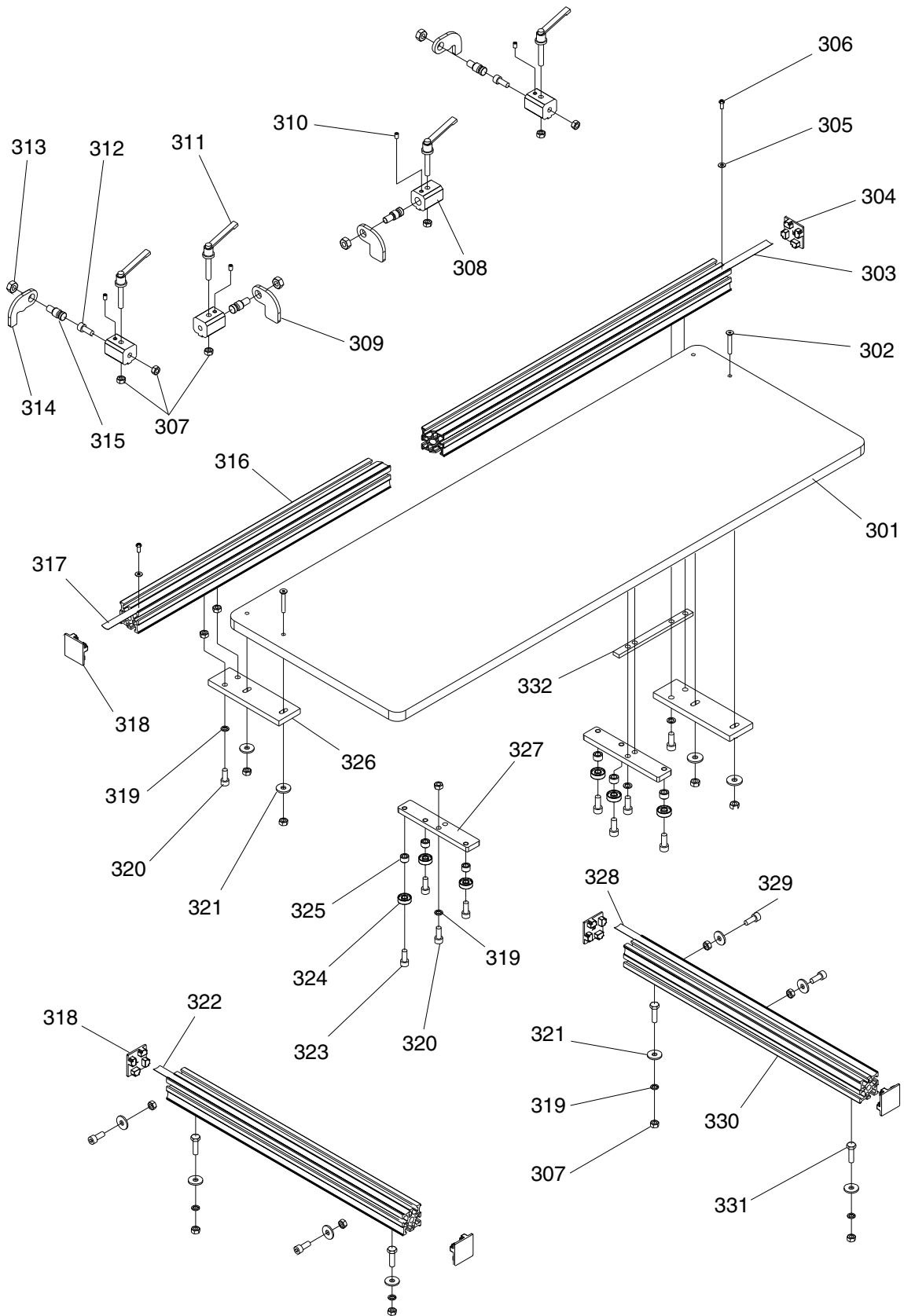

Table Parts List

REF	PART #	DESCRIPTION
301	P0643301	TABLE
302	P0643302	FLAT HD SCR M8-1.25 X 35
303	P0643303	SCALE RIGHT REAR
304	P0643304	RAIL PLUG RIGHT
305	P0643305	FLAT WASHER 5MM
306	P0643306	PHLP HD SCR M5-.8 X 12
307	P0643307	HEX NUT M8-1.25
308	P0643308	BRACKET
309	P0643309	LONGITUDINAL STOP PLATE
310	P0643310	SET SCREW M6-1 X 5
311	P0643311	LOCK HANDLE
312	P0643312	CAP SCREW M8-1.25 X 16
313	P0643313	LOCK NUT M10-1.5
314	P0643314	CROSS STOP PLATE
315	P0643315	SPECIAL BOLT
316	P0643316	RAIL REAR

REF	PART #	DESCRIPTION
317	P0643317	SCALE LEFT REAR
318	P0643318	RAIL PLUG LEFT
319	P0643319	LOCK WASHER 8MM
320	P0643320	CAP SCREW M8-1.25 X 20
321	P0643321	FLAT WASHER 8MM
322	P0643322	SCALE LEFT SIDE
323	P0643323	CAP SCREW M8-1.25 X 25
324	P0643324	BALL BEARING 608ZZ
325	P0643325	BUSHING
326	P0643326	TABLE MOUNT
327	P0643327	RAIL MOUNT
328	P0643328	SCALE RIGHT SIDE
329	P0643329	CAP SCREW M8-1.25 X 12
330	P0643330	RAIL SIDE
331	P0643331	HEX BOLT M8-1.25 X 25
332	P0643332	CONNECTION BAR



Cabinet & Tools Breakdown

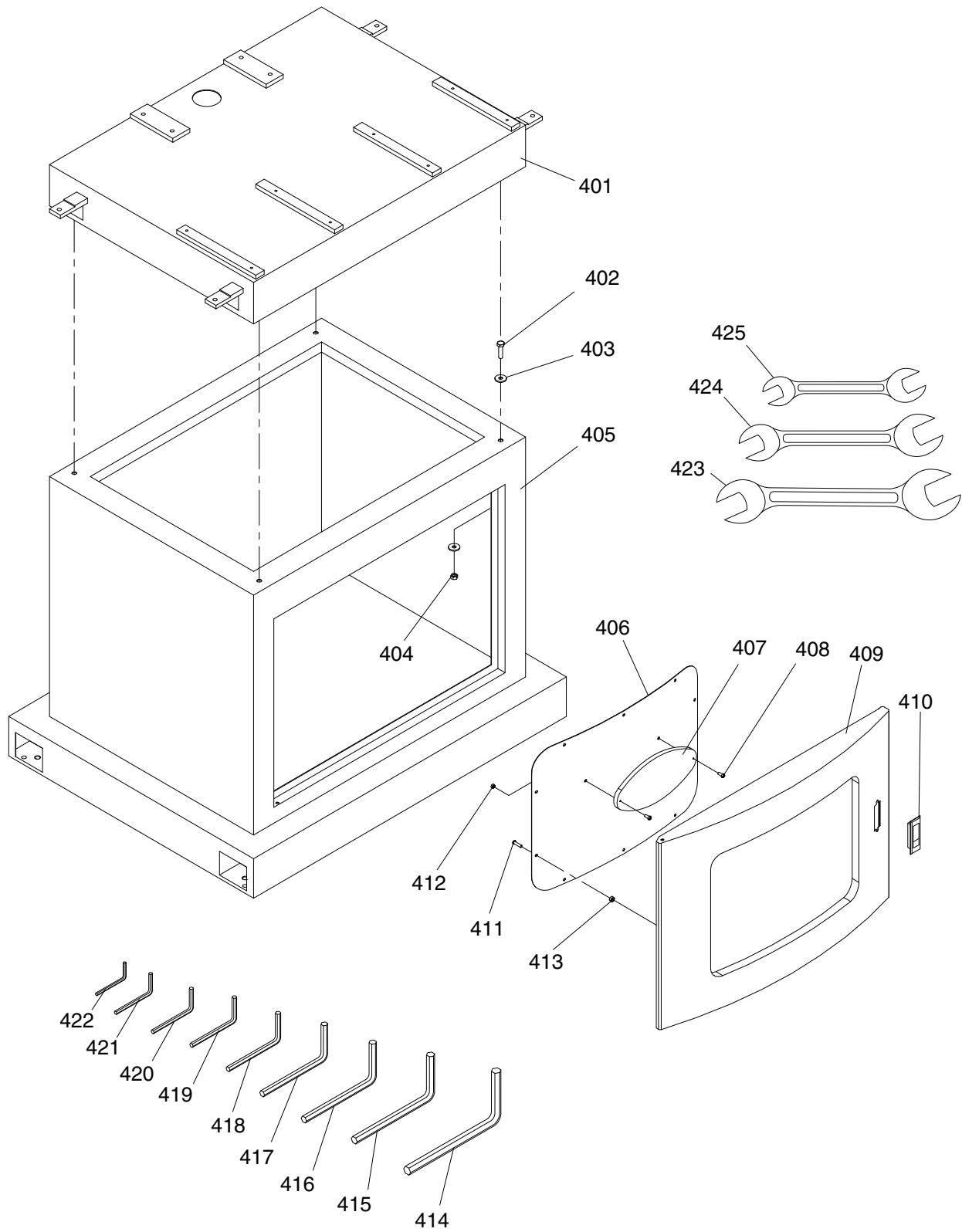

Cabinet & Tools Parts List

REF	PART #	DESCRIPTION
401	P0643401	CABINET TOP
402	P0643402	HEX BOLT M8-1.25 X 16
403	P0643403	FLAT WASHER 8MM
404	P0643404	HEX NUT M8-1.25
405	P0643405	CABINET BASE
406	P0643406	FRONT COVER
407	P0643407	GRIZZLY LOGO
408	P0643408	PHLP HD SCR M4-.7 X 12
409	P0643409	CABINET DOOR
410	P0643410	DOOR LATCH
411	P0643411	PHLP HD SCR M5-.8 X 12
412	P0643412	HEX NUT M4-.7
413	P0643413	HEX NUT M5-.8

REF	PART #	DESCRIPTION
414	P0643414	HEX WRENCH 10MM
415	P0643415	HEX WRENCH 8MM
416	P0643416	HEX WRENCH 6MM
417	P0643417	HEX WRENCH 5MM
418	P0643418	HEX WRENCH 4MM
419	P0643419	HEX WRENCH 3MM
420	P0643420	HEX WRENCH 2.5MM
421	P0643421	HEX WRENCH 2MM
422	P0643422	HEX WRENCH 1.5MM
423	P0643423	COMBO WRENCH 17/19MM
424	P0643424	COMBO WRENCH 11/13MM
425	P0643425	COMBO WRENCH 8/10MM



Boring Head Breakdown

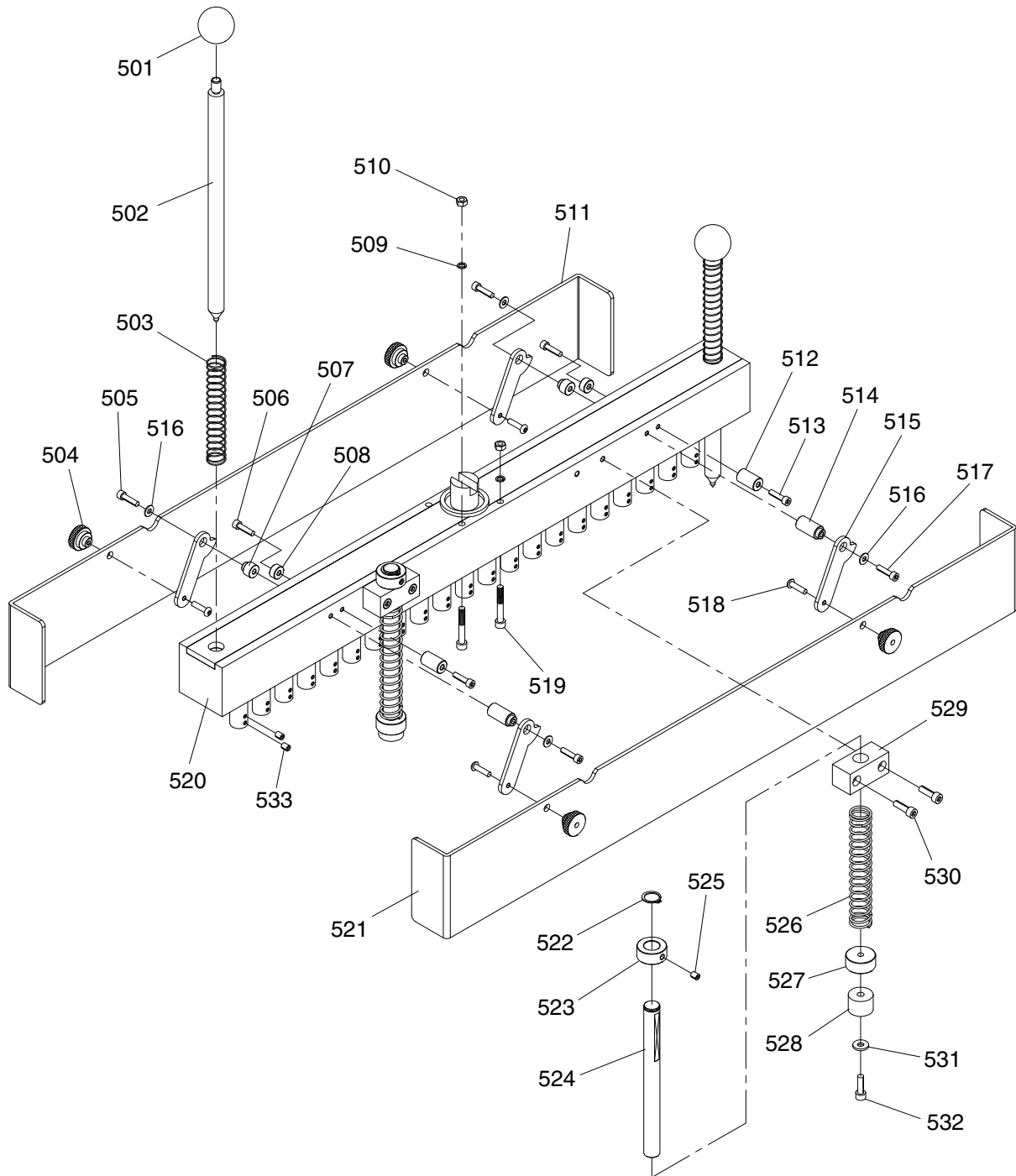

Boring Head Parts List

REF	PART #	DESCRIPTION
501	P0643501	KNOB
502	P0643502	INDEXING PIN
503	P0643503	INDEXING COMPRESSION SPRING
504	P0643504	KNURLED KNOB
505	P0643505	CAP SCREW M5-.8 X 25
506	P0643506	CAP SCREW M5-.8 X 16
507	P0643507	GUARD MOUNT BUSHING REAR
508	P0643508	HEAD SPACER REAR
509	P0643509	LOCK WASHER 6MM
510	P0643510	HEX NUT M6-1
511	P0643511	GUARD REAR
512	P0643512	HEAD SPACER FRONT
513	P0643513	CAP SCREW M5-.8 X 35
514	P0643514	GUARD MOUNT BUSHING FRONT
515	P0643515	GUARD MOUNT
516	P0643516	FLAT WASHER 5MM
517	P0643517	CAP SCREW M5-.8 X 50

REF	PART #	DESCRIPTION
518	P0643518	CAP SCREW M5-.8 X 20
519	P0643519	CAP SCREW M6-1 X 70
520	P0643520	BORING HEAD ASSY
521	P0643521	GUARD FRONT
522	P0643522	EXT RETAINING RING 16MM
523	P0643523	LOCK COLLAR
524	P0643524	HOLDDOWN SHAFT
525	P0643525	SET SCREW M6-1 X 5
526	P0643526	HOLDDOWN COMPRESSION SPRING
527	P0643527	COLLAR
528	P0643528	HOLDDOWN PAD
529	P0643529	HOLDDOWN MOUNT
530	P0643530	CAP SCREW M6-1 X 30
531	P0643531	FLAT WASHER 6MM
532	P0643532	CAP SCREW M6-1 X 20
533	P0643533	SET SCREW M5-.8 X 5



Label Placement & List

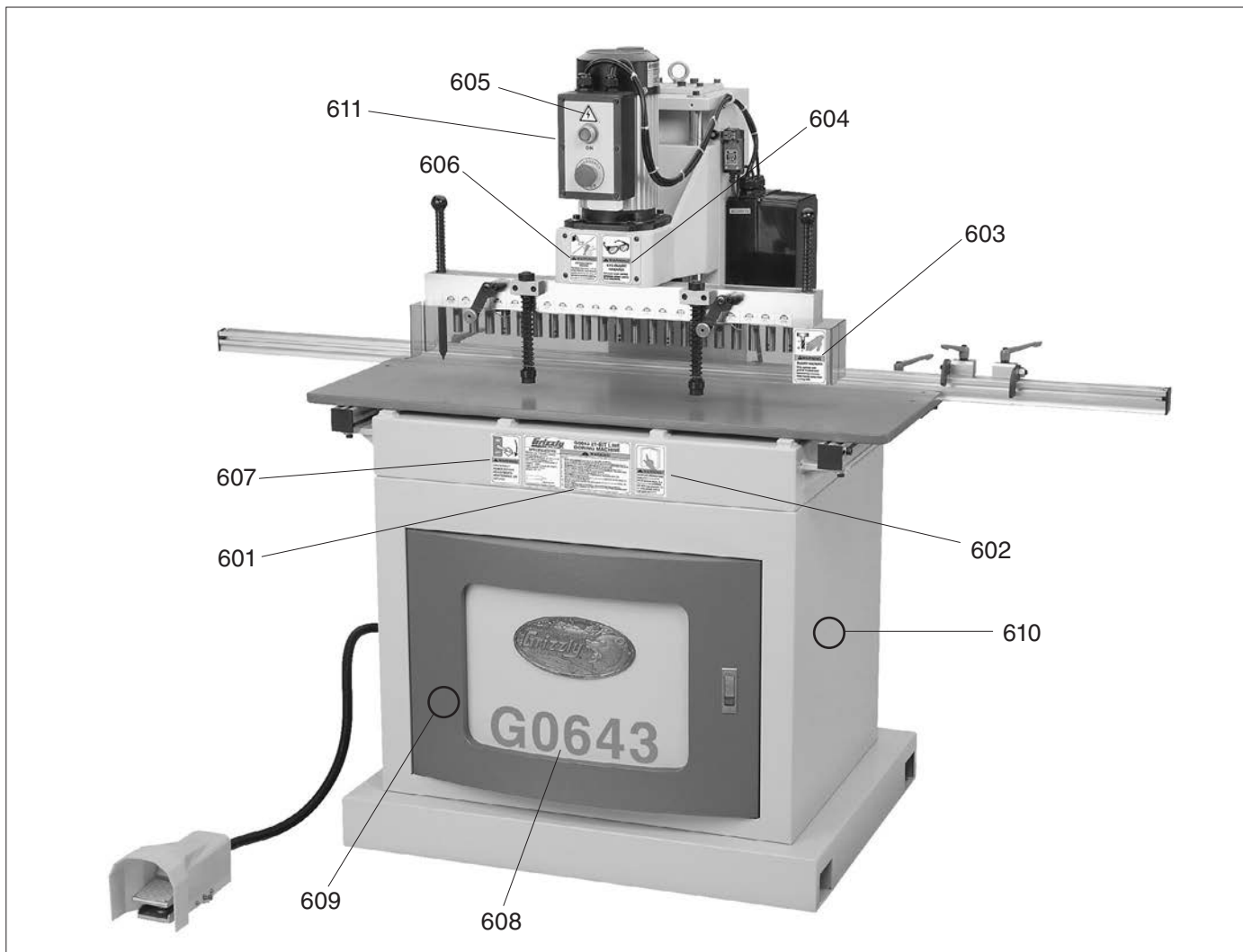

REF	PART #	DESCRIPTION
601	P0643601	MACHINE ID LABEL
602	P0643602	READ MANUAL LABEL VERT
603	P0643603	HAND INJURY LABEL VERT
604	P0643604	EYE HAZARD LABEL VERT
605	P0643605	ELECTRICITY LABEL
606	P0643606	ENTANGLEMENT LABEL VERT

REF	PART #	DESCRIPTION
607	P0643607	DISCONNECT POWER LABEL VERT
608	P0643608	MODEL NUMBER LABEL
609	P0643609	GRIZZLY GREEN TCH/UP PAINT
610	P0643610	GRIZZLY PUDDY TCH/UP PAINT
611	P0643611	DOWNFEED SPEED LABEL

WARNING

Safety labels help reduce the risk of serious injury caused by machine hazards. If any label comes off or becomes unreadable, the owner of this machine **MUST** replace it in the original location before resuming operations. For replacements, contact (800) 523-4777 or www.grizzly.com.





WARRANTY CARD

Name _____
 Street _____
 City _____ State _____ Zip _____
 Phone # _____ Email _____
 Model # _____ Order # _____ Serial # _____

The following information is given on a voluntary basis. It will be used for marketing purposes to help us develop better products and services. **Of course, all information is strictly confidential.**

- How did you learn about us?

<input type="checkbox"/> Advertisement	<input type="checkbox"/> Friend	<input type="checkbox"/> Catalog
<input type="checkbox"/> Card Deck	<input type="checkbox"/> Website	<input type="checkbox"/> Other:
- Which of the following magazines do you subscribe to?

<input type="checkbox"/> Cabinetmaker & FDM	<input type="checkbox"/> Popular Science	<input type="checkbox"/> Wooden Boat
<input type="checkbox"/> Family Handyman	<input type="checkbox"/> Popular Woodworking	<input type="checkbox"/> Woodshop News
<input type="checkbox"/> Hand Loader	<input type="checkbox"/> Precision Shooter	<input type="checkbox"/> Woodsmith
<input type="checkbox"/> Handy	<input type="checkbox"/> Projects in Metal	<input type="checkbox"/> Woodwork
<input type="checkbox"/> Home Shop Machinist	<input type="checkbox"/> RC Modeler	<input type="checkbox"/> Woodworker West
<input type="checkbox"/> Journal of Light Cont.	<input type="checkbox"/> Rifle	<input type="checkbox"/> Woodworker's Journal
<input type="checkbox"/> Live Steam	<input type="checkbox"/> Shop Notes	<input type="checkbox"/> Other:
<input type="checkbox"/> Model Airplane News	<input type="checkbox"/> Shotgun News	
<input type="checkbox"/> Old House Journal	<input type="checkbox"/> Today's Homeowner	
<input type="checkbox"/> Popular Mechanics	<input type="checkbox"/> Wood	
- What is your annual household income?

<input type="checkbox"/> \$20,000-\$29,000	<input type="checkbox"/> \$30,000-\$39,000	<input type="checkbox"/> \$40,000-\$49,000
<input type="checkbox"/> \$50,000-\$59,000	<input type="checkbox"/> \$60,000-\$69,000	<input type="checkbox"/> \$70,000+
- What is your age group?

<input type="checkbox"/> 20-29	<input type="checkbox"/> 30-39	<input type="checkbox"/> 40-49
<input type="checkbox"/> 50-59	<input type="checkbox"/> 60-69	<input type="checkbox"/> 70+
- How long have you been a woodworker/metalworker?

<input type="checkbox"/> 0-2 Years	<input type="checkbox"/> 2-8 Years	<input type="checkbox"/> 8-20 Years	<input type="checkbox"/> 20+ Years
------------------------------------	------------------------------------	-------------------------------------	------------------------------------
- How many of your machines or tools are Grizzly?

<input type="checkbox"/> 0-2	<input type="checkbox"/> 3-5	<input type="checkbox"/> 6-9	<input type="checkbox"/> 10+
------------------------------	------------------------------	------------------------------	------------------------------
- Do you think your machine represents a good value? Yes No
- Would you recommend Grizzly Industrial to a friend? Yes No
- Would you allow us to use your name as a reference for Grizzly customers in your area?
Note: We never use names more than 3 times. Yes No

10. Comments: _____

CUT ALONG DOTTED LINE

FOLD ALONG DOTTED LINE



Place
Stamp
Here



GRIZZLY INDUSTRIAL, INC.
P.O. BOX 2069
BELLINGHAM, WA 98227-2069



FOLD ALONG DOTTED LINE

Send a Grizzly Catalog to a friend:

Name _____
Street _____
City _____ State _____ Zip _____

TAPE ALONG EDGES--PLEASE DO NOT STAPLE



WARRANTY CARD

Name _____
 Street _____
 City _____ State _____ Zip _____
 Phone # _____ Email _____
 Model # _____ Order # _____ Serial # _____

The following information is given on a voluntary basis. It will be used for marketing purposes to help us develop better products and services. **Of course, all information is strictly confidential.**

1. How did you learn about us?

<input type="checkbox"/> Advertisement	<input type="checkbox"/> Friend	<input type="checkbox"/> Catalog
<input type="checkbox"/> Card Deck	<input type="checkbox"/> Website	<input type="checkbox"/> Other:

2. Which of the following magazines do you subscribe to?

<input type="checkbox"/> Cabinetmaker & FDM	<input type="checkbox"/> Popular Science	<input type="checkbox"/> Wooden Boat
<input type="checkbox"/> Family Handyman	<input type="checkbox"/> Popular Woodworking	<input type="checkbox"/> Woodshop News
<input type="checkbox"/> Hand Loader	<input type="checkbox"/> Precision Shooter	<input type="checkbox"/> Woodsmith
<input type="checkbox"/> Handy	<input type="checkbox"/> Projects in Metal	<input type="checkbox"/> Woodwork
<input type="checkbox"/> Home Shop Machinist	<input type="checkbox"/> RC Modeler	<input type="checkbox"/> Woodworker West
<input type="checkbox"/> Journal of Light Cont.	<input type="checkbox"/> Rifle	<input type="checkbox"/> Woodworker's Journal
<input type="checkbox"/> Live Steam	<input type="checkbox"/> Shop Notes	<input type="checkbox"/> Other:
<input type="checkbox"/> Model Airplane News	<input type="checkbox"/> Shotgun News	
<input type="checkbox"/> Old House Journal	<input type="checkbox"/> Today's Homeowner	
<input type="checkbox"/> Popular Mechanics	<input type="checkbox"/> Wood	

3. What is your annual household income?

<input type="checkbox"/> \$20,000-\$29,000	<input type="checkbox"/> \$30,000-\$39,000	<input type="checkbox"/> \$40,000-\$49,000
<input type="checkbox"/> \$50,000-\$59,000	<input type="checkbox"/> \$60,000-\$69,000	<input type="checkbox"/> \$70,000+

4. What is your age group?

<input type="checkbox"/> 20-29	<input type="checkbox"/> 30-39	<input type="checkbox"/> 40-49
<input type="checkbox"/> 50-59	<input type="checkbox"/> 60-69	<input type="checkbox"/> 70+

5. How long have you been a woodworker/metalworker?

<input type="checkbox"/> 0-2 Years	<input type="checkbox"/> 2-8 Years	<input type="checkbox"/> 8-20 Years	<input type="checkbox"/> 20+ Years
------------------------------------	------------------------------------	-------------------------------------	------------------------------------

6. How many of your machines or tools are Grizzly?

<input type="checkbox"/> 0-2	<input type="checkbox"/> 3-5	<input type="checkbox"/> 6-9	<input type="checkbox"/> 10+
------------------------------	------------------------------	------------------------------	------------------------------

7. Do you think your machine represents a good value? Yes No
8. Would you recommend Grizzly Industrial to a friend? Yes No
9. Would you allow us to use your name as a reference for Grizzly customers in your area?
Note: We never use names more than 3 times. Yes No

10. Comments: _____

CUT ALONG DOTTED LINE

grizzly.com[®]

TOOL WEBSITE

Buy Direct and Save with Grizzly[®] – Trusted, Proven and a Great Value!
~Since 1983~

*Visit Our Website Today For
Current Specials!*

**ORDER
24 HOURS A DAY!
1-800-523-4777**

