

Grizzly *Industrial, Inc.*®

MODEL G0688 TOOL POST GRINDER OWNER'S MANUAL



COPYRIGHT © AUGUST, 2009 BY GRIZZLY INDUSTRIAL, INC.
**WARNING: NO PORTION OF THIS MANUAL MAY BE REPRODUCED IN ANY SHAPE
OR FORM WITHOUT THE WRITTEN APPROVAL OF GRIZZLY INDUSTRIAL, INC.**
(FOR MODELS MANUFACTURED SINCE 9/08) #TS11354 PRINTED IN TAIWAN

 **WARNING!**

This manual provides critical safety instructions on the proper setup, operation, maintenance and service of this machine/equipment.

Failure to read, understand and follow the instructions given in this manual may result in serious personal injury, including amputation, electrocution or death.

The owner of this machine/equipment is solely responsible for its safe use. This responsibility includes but is not limited to proper installation in a safe environment, personnel training and usage authorization, proper inspection and maintenance, manual availability and comprehension, application of safety devices, blade/cutter integrity, and the usage of personal protective equipment.

The manufacturer will not be held liable for injury or property damage from negligence, improper training, machine modifications or misuse.

 **WARNING!**

Some dust created by power sanding, sawing, grinding, drilling, and other construction activities contains chemicals known to the State of California to cause cancer, birth defects or other reproductive harm. Some examples of these chemicals are:

- **Lead from lead-based paints.**
- **Crystalline silica from bricks, cement and other masonry products.**
- **Arsenic and chromium from chemically-treated lumber.**

Your risk from these exposures varies, depending on how often you do this type of work. To reduce your exposure to these chemicals: Work in a well ventilated area, and work with approved safety equipment, such as those dust masks that are specially designed to filter out microscopic particles.

Table of Contents

- INTRODUCTION..... 2**
 - Manual Accuracy..... 2
 - Contact Info..... 2
 - Machine Description..... 2
 - Identification..... 3
 - Machine Data Sheet..... 4

- SECTION 1: SAFETY 6**
 - Safety Instructions for Machinery..... 6
 - Additional Safety Instructions for Tool Post Grinders 8

- SECTION 2: CIRCUIT REQUIREMENTS 9**

- SECTION 3: SETUP 10**
 - Needed for Setup..... 10
 - Unpacking 10
 - Inventory..... 11
 - Clean Up 11
 - Lathe Requirements..... 12
 - Mounting Grinder On Lathe..... 12
 - Adjusting Grinder Spindle Centerline..... 13
 - Test Run..... 14

- SECTION 4: OPERATIONS 15**
 - Operation Overview..... 15
 - Lathe Rotation..... 16
 - Internal Wheel..... 16
 - External Wheel..... 20
 - External Wheel Flange..... 22
 - Balancing External Wheel..... 23
 - Wheel Care..... 24
 - Wheel Inspection & Ring Test..... 25
 - Wheel Dressing..... 26

- SECTION 5: ACCESSORIES..... 27**

- SECTION 6: MAINTENANCE..... 30**
 - Schedule..... 30
 - Cleaning & Protecting 30
 - Lathe Bedway..... 30
 - Lubrication..... 30

- SECTION 7: SERVICE 31**
 - Troubleshooting..... 31

- SECTION 8: WIRING..... 33**
 - Wiring Safety Instructions 33
 - Wiring Diagram..... 34

- SECTION 9: PARTS..... 35**
 - Main..... 35
 - Accessories..... 37
 - Label Placement..... 38

- WARRANTY AND RETURNS 41**

INTRODUCTION

Manual Accuracy

We are proud to offer this manual with your new machine! We've made every effort to be exact with the instructions, specifications, drawings, and photographs of the machine we used when writing this manual. However, sometimes errors do happen and we apologize for them.

Also, owing to our policy of continuous improvement, **your machine may not exactly match the manual**. If you find this to be the case, and the difference between the manual and machine leaves you in doubt, check our website for the latest manual update or call technical support for help.

Before calling, find the manufacture date of your machine by looking at the date stamped into the machine ID label (see below). This will help us determine if the manual version you received matches the manufacture date of your machine.

		MODEL GXXXX MACHINE NAME	
SPECIFICATIONS		▲ WARNING!	
Motor:		Manufacture Date of Your Machine ing this machine: operation. s and respirator. sted/setup and suit before starting.	
Specification:			
Specification:			
Specification:			
Weight:			
<input type="text"/>	Date	<ol style="list-style-type: none">4. make sure the motor has stopped and disconnect power before adjustments, maintenance, or service.5. DO NOT expose to rain or dampness.6. DO NOT modify this machine in any way.7. DO NOT remove safety guards.8. Never leave machine running unattended.9. DO NOT operate under the influence of drugs or alcohol.10. Maintain machine carefully to prevent accidents.	
<input type="text"/>	Serial Number		
Manufactured for Grizzly in Taiwan			

For your convenience, we post all available manuals and manual updates for free on our website at www.grizzly.com. Any updates to your model of machine will be reflected in these documents as soon as they are complete.

Contact Info

We stand behind our machines. If you have any service questions, parts requests or general questions about the machine, please call or write us at the location listed below.

Grizzly Industrial, Inc.
1203 Lycoming Mall Circle
Muncy, PA 17756
Phone: (570) 546-9663
Fax: (800) 438-5901
E-Mail: techsupport@grizzly.com

If you have any comments regarding this manual, please write to us at the address below:

Grizzly Industrial, Inc.
c/o Technical Documentation Manager
P.O. Box 2069
Bellingham, WA 98227-2069
Email: manuals@grizzly.com

Machine Description

The Model G0688 Tool Post Grinder enables finishes on concentric workpieces that lathe cutting tools cannot provide.

The grinder is mounted on the tool post stud of the lathe. The operator orients the grinding face of the wheel parallel with the workpiece, starts the lathe and grinder, then moves the wheel across the workpiece surface.

The external grinding wheel finishes the outside of workpiece, and the internal wheel finishes the inside walls of a concentric workpiece cavity.

The Model G0688 is designed for dry or wet grinding.



Identification

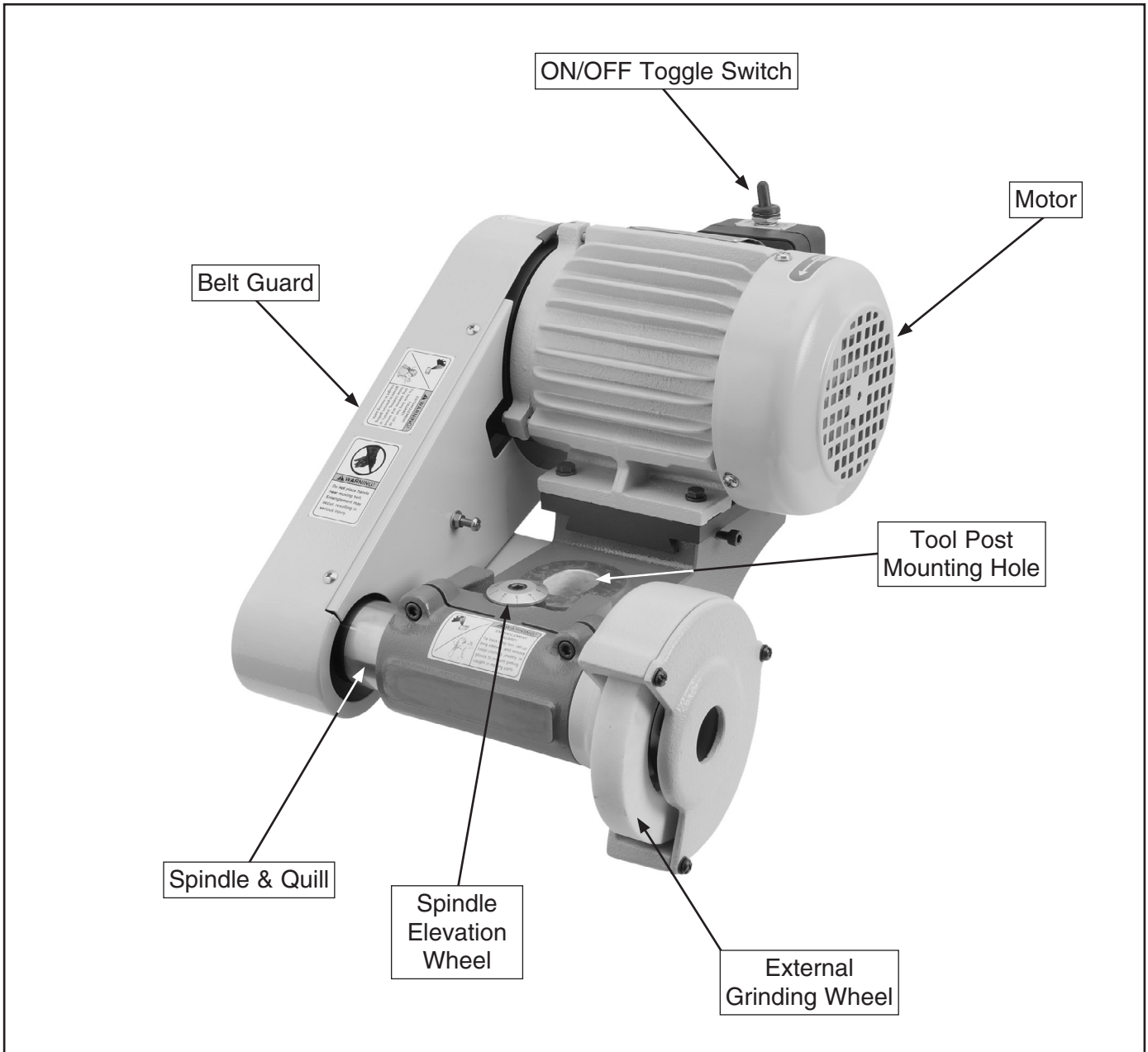

Figure 1. Model G0688 identification.

	<p>⚠ WARNING</p> <p>To reduce the risk of serious injury when using this machine, read and understand this entire manual before beginning any operations.</p>
--	--





MACHINE DATA SHEET

Customer Service #: (570) 546-9663 • To Order Call: (800) 523-4777 • Fax #: (800) 438-5901

MODEL G0688 TOOL POST GRINDER

Product Dimensions:

Weight 57 lbs.
Length/Width/Height 18" x 11½" x 12"

Shipping Dimensions:

Type Wood Crate
Content..... Machine
Weight 88 lbs.
Length/Width/Height..... 18" x 13½" x 16"

Electrical:

Required Power Source..... 220V, 3-Phase
Switch..... ON/OFF Toggle Switch
Switch Voltage 220V
Cord Length 8 ft.
Cord Gauge 16 gauge
Recommended Circuit Size 15 amp
Included Plug No
Plug Type..... NEMA 15-15

Motor:

Type TEFC
Horsepower..... ½ HP
Voltage 220V
Phase Three
Amps 2A
Speed..... 3450 RPM
Cycle 60 Hz
Number Of Speeds 1
Power Transfer Belt Drive
Bearings Shielded and Permanently Lubricated

Main Specifications:

Operation Information

External Grinding Wheel Speed 4500 RPM
External Grinding Wheel Size 5"D x ¾"W x 1⅝"B
Internal Grinding Wheel Speed 16500, 23000 RPM
Internal Grinding Wheel Spindle Thread M10-1.5
Max. Tool Post Diameter Capacity..... 1"
Height Range of Grinder Spindle Center Line from Compound Slide 1⅝"-2⅝"



Construction

Body Construction Cast-Iron
Spindle..... Balanced, Hardened & Ground Alloy Steel
Paint Urethane

Other Specifications:

Country Of Origin Taiwan
Warranty..... 1 Year
Serial Number Location ID Label on Machine

Features:

- Mounts Directly to Lathe Tool Post
- Low-Speed Range for External Grinding Wheels
- High-Speed Ranges for Internal Grinding Wheels
- Balanced, Hardened Alloy Steel Spindle
- Designed for Dry or Wet Grinding



SECTION 1: SAFETY

WARNING

For Your Own Safety, Read Instruction Manual Before Operating this Machine

The purpose of safety symbols is to attract your attention to possible hazardous conditions. This manual uses a series of symbols and signal words intended to convey the level of importance of the safety messages. The progression of symbols is described below. Remember that safety messages by themselves do not eliminate danger and are not a substitute for proper accident prevention measures.



Indicates an imminently hazardous situation which, if not avoided, **WILL** result in death or serious injury.



Indicates a potentially hazardous situation which, if not avoided, **COULD** result in death or serious injury.



Indicates a potentially hazardous situation which, if not avoided, **MAY** result in minor or moderate injury. It may also be used to alert against unsafe practices.

NOTICE

This symbol is used to alert the user to useful information about proper operation of the machine.

WARNING

Safety Instructions for Machinery

- 1. READ ENTIRE MANUAL BEFORE STARTING.** Operating machine before reading the manual greatly increases the risk of injury.
- 2. ALWAYS USE ANSI APPROVED SAFETY GLASSES WHEN OPERATING MACHINERY.** Everyday eyeglasses only have impact resistant lenses—they are NOT safety glasses.
- 3. ALWAYS WEAR A NIOSH APPROVED RESPIRATOR WHEN OPERATING MACHINERY THAT PRODUCES DUST.** Most types of dust (wood, metal, etc.) can cause severe respiratory illnesses.
- 4. ALWAYS USE HEARING PROTECTION WHEN OPERATING MACHINERY.** Machinery noise can cause permanent hearing loss.
- 5. WEAR PROPER APPAREL. DO NOT** wear loose clothing, gloves, neckties, rings, or jewelry that can catch in moving parts. Wear protective hair covering to contain long hair and wear non-slip footwear.
- 6. NEVER OPERATE MACHINERY WHEN TIRED OR UNDER THE INFLUENCE OF DRUGS OR ALCOHOL.** Be mentally alert at all times when running machinery.



WARNING

Safety Instructions for Machinery

7. **ONLY ALLOW TRAINED AND PROPERLY SUPERVISED PERSONNEL TO OPERATE MACHINERY.** Make sure operation instructions are safe and clearly understood.
8. **KEEP CHILDREN/VISITORS AWAY.** Keep all children and visitors away from machinery. When machine is not in use, disconnect it from power, lock it out, or disable the switch to make it difficult for unauthorized people to start the machine.
9. **UNATTENDED OPERATION.** Leaving machine unattended while its running greatly increases the risk of an accident or property damage. Turn machine **OFF** and allow all moving parts to come to a complete stop before walking away.
10. **DO NOT USE IN DANGEROUS ENVIRONMENTS.** DO NOT use machinery in damp, wet locations, or where any flammable or noxious fumes may exist.
11. **KEEP WORK AREA CLEAN AND WELL LIGHTED.** Clutter and dark shadows may cause accidents.
12. **USE A GROUNDED POWER SUPPLY RATED FOR THE MACHINE AMPERAGE.** Grounded cords minimize shock hazards. Operating machine on an incorrect size of circuit increases risk of fire.
13. **ALWAYS DISCONNECT FROM POWER SOURCE BEFORE SERVICING MACHINERY.** Make sure switch is in OFF position before reconnecting.
14. **MAINTAIN MACHINERY WITH CARE.** Keep blades sharp and clean for best and safest performance. Follow instructions for lubricating and changing accessories.
15. **MAKE SURE GUARDS ARE IN PLACE AND WORK CORRECTLY BEFORE USING MACHINERY.**
16. **REMOVE CHUCK KEYS OR ADJUSTING TOOLS.** Make a habit of never leaving chuck keys or other adjustment tools in/on the machine—especially near spindles!
17. **DAMAGED MACHINERY.** Check for binding or misaligned parts, broken parts, loose bolts, other conditions that may impair machine operation. Always repair or replace damaged parts before operation.
18. **DO NOT FORCE MACHINERY.** Work at the speed for which the machine or accessory was designed.
19. **SECURE WORKPIECE.** Use clamps or a vise to hold the workpiece when practical. A secured workpiece protects your hands and frees both hands to operate the machine.
20. **DO NOT OVERREACH.** Maintain stability and balance at all times when operating machine.
21. **MANY MACHINES CAN EJECT WORKPIECES TOWARD OPERATOR.** Know and avoid conditions that cause the workpiece to "kickback."
22. **STABLE MACHINE.** Machines that move during operations greatly increase the risk of injury and loss of control. Verify machines are stable/secure and mobile bases (if used) are locked before starting.
23. **CERTAIN DUST MAY BE HAZARDOUS** to the respiratory systems of people and animals, especially fine dust. Be aware of the type of dust you are exposed to and always wear a respirator designed to filter that type of dust.
24. **EXPERIENCING DIFFICULTIES.** If at any time you are experiencing difficulties performing the intended operation, stop using the machine! Contact our Technical Support Department at (570) 546-9663.



WARNING

Additional Safety Instructions for Tool Post Grinders

- 1. LATHE OWNER'S MANUAL.** Read and understand the entire owner's manual for your lathe, and follow all of the safety precautions and instructions it contains.
- 2. MOUNTING ON LATHE.** An unexpected movement of the grinder could cause the grinding wheel to break apart and cause serious personal injury or property damage. Always make sure the grinder is properly secured to the tool post before operation.
- 3. EYE PROTECTION.** Grinding causes small particles to become airborne at a high rate of speed. Always wear ANSI approved safety glasses or face shield when using this machine.
- 4. WHEEL SPEED RATING.** Wheels operated at a faster speed than rated may fly apart during use. Before mounting a new wheel, be sure the wheel RPM rating is equal to or higher than the speed of the grinder.
- 5. PULLEY & WHEEL HARDWARE.** Using pulleys or wheel mounting hardware other than those supplied with this grinder could cause the pulleys or wheels to come loose during operation and cause serious personal injury or property damage. Only use the pulleys and wheel mounting hardware that are included with this grinder.
- 6. WHEEL INSPECTION.** Visually inspect the wheel and, for the external wheel, perform the "ring test" before installation to ensure that it is safe to use. A wheel that is damaged in any way could fly apart during operation—DO NOT use it!
- 7. STARTING GRINDER.** If a grinding wheel is damaged, it will usually fly apart shortly after start-up. Before starting the grinder, stand to one side of the wheel and allow it to run at full speed for at least one minute before standing in front of it.
- 8. LUNG PROTECTION.** Grinding produces hazardous dust, which may cause long-term respiratory problems if breathed. Always wear a NIOSH approved dust mask or respirator when grinding.
- 9. HAND/WHEEL CONTACT.** Grinding wheels have the capability of removing a lot of skin quickly. Keep your hands at a safe distance away from the wheel when grinding. Do not wear gloves when grinding as they may get caught in the spinning wheel or pulleys causing serious entanglement injuries.
- 10. GUARDS.** To avoid serious entanglement injuries, the wheel and belt guards must be properly during all operations.

WARNING

Like all machinery there is potential danger when operating this machine. Accidents are frequently caused by lack of familiarity or failure to pay attention. Use this machine with respect and caution to decrease the risk of operator injury. If normal safety precautions are overlooked or ignored, serious personal injury may occur.

CAUTION

No list of safety guidelines can be complete. Every shop environment is different. Always consider safety first, as it applies to your individual working conditions. Use this and other machinery with caution and respect. Failure to do so could result in serious personal injury, damage to equipment, or poor work results.



SECTION 2: CIRCUIT REQUIREMENTS

! WARNING
 Serious personal injury could occur if you connect the machine to power before completing the mounting process. **DO NOT** connect the machine to the power until instructed later in this manual.

! WARNING
 Electrocutation or fire could result if machine is not grounded and installed in compliance with electrical codes. Compliance **MUST** be verified by a qualified electrician!



Power Connection Device

The type of plug required to connect your machine to power depends on the type of service you currently have or plan to install. We recommend using the plug shown in **Figure 2**.

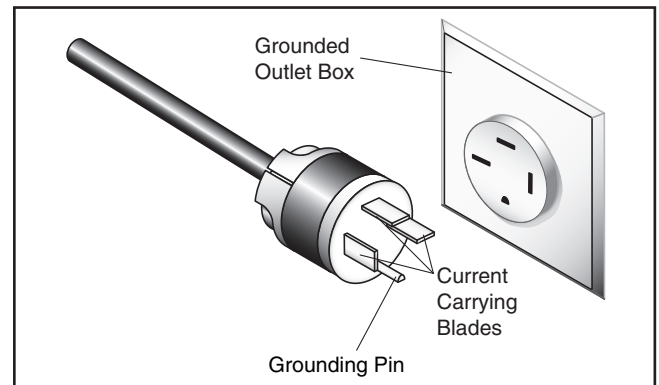

Figure 2. NEMA 15-15 plug and receptacle.

Full Load Amperage Draw

This machine draws the following amps under maximum load:

Amp Draw..... 2 Amps

Power Supply Circuit Requirements

The power supply circuit for your machine **MUST** be grounded and rated for the amperage given below. Never replace a circuit breaker on an existing circuit with one of higher amperage without consulting a qualified electrician to ensure compliance with wiring codes. **If you are unsure about the wiring codes in your area or you plan to connect your machine to a shared circuit, consult a qualified electrician.**

Minimum Circuit Size..... 15 Amps
 Power Source 220V, 3-Phase

Extension Cords

Using extension cords may reduce the life of the motor. Instead, place the machine near a power source. If you must use an extension cord:

- Use at least a 16 gauge cord that does not exceed 50 feet in length!
- The extension cord must also have a ground wire and plug pin.
- A qualified electrician **MUST** size cords over 50 feet long to prevent motor damage.



SECTION 3: SETUP

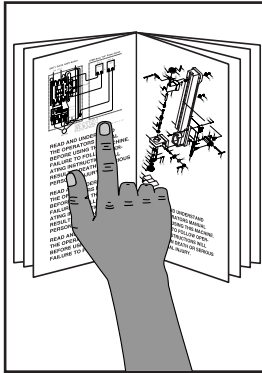

!WARNING
 This machine presents serious injury hazards to untrained users. Read through this entire manual to become familiar with the controls and operations before starting the machine!



!WARNING
 Wear safety glasses during the entire setup process!

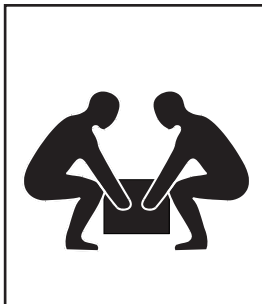

!WARNING
 This machine and its components are very heavy. Get lifting help to move heavy items and mount the machine onto your lathe.

Needed for Setup

The following are needed to complete the setup process, but are not included with your machine:

Description	Qty
• Safety Glasses	1 Per Person
• Shop Rags & Solvent	As Needed
• Hex Wrench 5mm.....	1
• Tool Post Nut.....	1
• Tool Post Bushing (If Needed)	1

Unpacking

Your machine was carefully packaged for safe transportation. Remove the packaging materials from around your machine and inspect it. If you discover the machine is damaged, *please immediately call Customer Service at (570) 546-9663 for advice.*

Save the containers and all packing materials for possible inspection by the carrier or its agent. *Otherwise, filing a freight claim can be difficult.*

When you are completely satisfied with the condition of your shipment, inventory the contents.

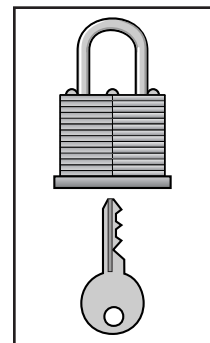

!CAUTION
 Children and visitors may be seriously injured if unsupervised around this machine. Lock entrances to the shop or disable start switch or power connection to prevent unsupervised use.



Inventory

The following is a description of the main components shipped with your machine. Lay the components out to inventory them.

Note: *If you can't find an item on this list, check the mounting location on the machine or examine the packaging materials carefully. Occasionally we pre-install certain components for shipping purposes.*

Inventory: (Figure 3)	Qty
A. Internal Grinding Wheel 1" Diameter.....	1
B. Hex Wrenches 2.5, 4, 5, 6mm.....	1 Each
C. Internal Spindle Pulley 16,500 RPM.....	1
D. Flat Belt 20 x 770mm.....	1
E. Puller Tool.....	1
F. Dresser Tool Assembly.....	1
G. Wheel Balancing Arbor.....	1
H. Internal Spindle Pulley 23,000 RPM.....	1
I. Installed:	
—External Grinding Wheel 5" Diameter.....	1
—V-Belt M28.....	1

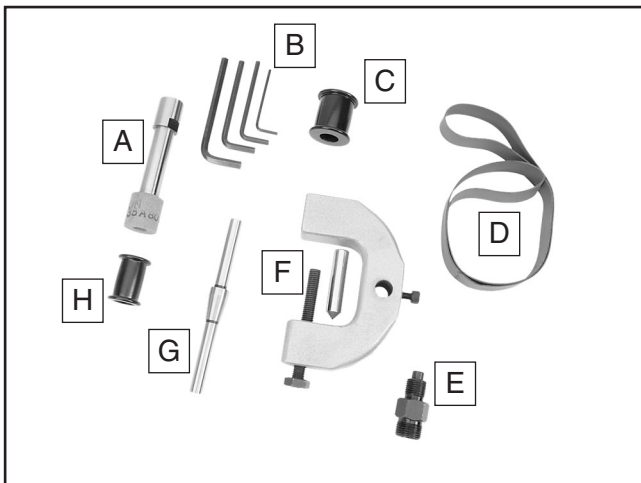



Figure 3. Model G0688 inventory.



⚠️ WARNING
SUFFOCATION HAZARD!
 Immediately discard all plastic bags and packing materials to eliminate choking/suffocation hazards for children and animals.

Clean Up

The unpainted surfaces are coated with a waxy oil to prevent corrosion during shipment. Remove this protective coating with a solvent cleaner or degreaser, such as shown in **Figure 4**. For thorough cleaning, some parts must be removed. **For optimum performance, clean all moving parts or sliding contact surfaces.** Avoid chlorine-based solvents, such as acetone or brake parts cleaner that may damage painted surfaces. Always follow the manufacturer's instructions when using any type of cleaning product.



⚠️ WARNING
 Gasoline and petroleum products have low flash points and can explode or cause fire if used to clean machinery. **DO NOT** use these products to clean the machinery.

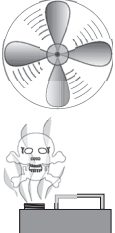

⚠️ CAUTION
 Many cleaning solvents are toxic if inhaled. Minimize your risk by only using these products in a well ventilated area.

G2544—Solvent Cleaner & Degreaser

H9692—Orange Power Degreaser

Great products for removing shipping grease.



Call
1-800-523-4777
 To Order

Figure 4. Cleaner/degreasers available from Grizzly.



Lathe Requirements

The Model G0688 is designed to work with metal lathes that have a 12" swing or greater. Use the following requirements to verify that your lathe will accommodate the grinder.

Tool Post

The maximum tool post diameter the grinder can accommodate is 1". If the diameter of your tool post does not allow you to secure the grinder to the compound slide without side-to-side movement, make a bushing for the tool post that will keep the grinder secured in place when the post nut is fully tightened down.

Centerline Alignment

When using the external grinding wheel, the centerline of the grinder spindle **MUST** be at the same height as the lathe centerline to reduce the risk of the wheel guard making contact with the spinning workpiece. The grinder spindle centerline is adjustable between $1\frac{5}{8}$ "– $2\frac{5}{8}$ " above the top of the top surface of the tool post. Measure the height of the lathe centerline above the tool post base (distance **A** illustrated in **Figure 5**) and make sure it is within this range.

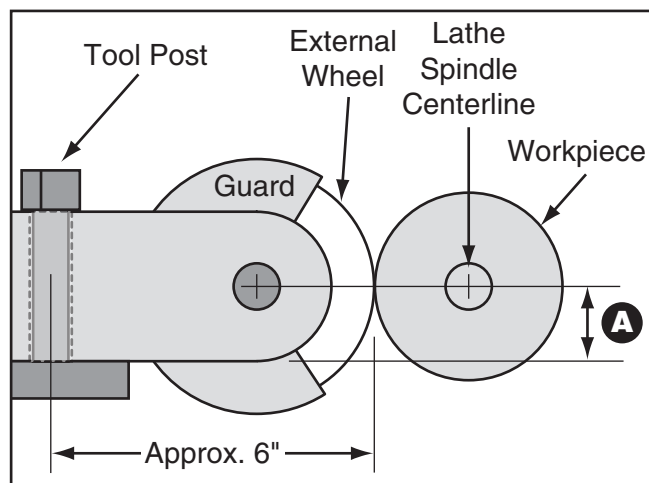

Figure 5. External wheel alignment.

External Wheel Clearance

The distance from the tool post center and the outside grinding surface of a new 5" external wheel is approximately 6" when the grinder is installed, as illustrated in **Figure 5**. Make sure that your compound slide can safely accommodate this distance from the workpiece.

Mounting Grinder On Lathe

To mount the grinder on your lathe:

1. DISCONNECT LATHE FROM POWER!
2. Remove the tool post nut or lever and any tool hardware from the tool post stud.
3. If mounted, remove the follow and steady rests.
4. Rotate the compound slide parallel to the lathe centerline, then tighten the rotation locks of the slide.
5. Place the grinder over the tool post stud and position it so that the grinding wheel is facing the lathe's centerline, as shown in **Figure 6**.

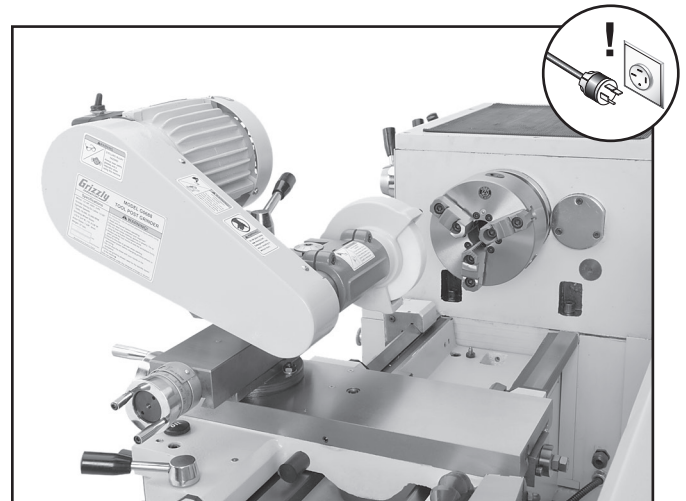

Figure 6. Grinder installed on the lathe.



!WARNING

Unexpected movement of the grinder on the tool post stud could cause the grinding wheel to break apart and become an injury hazard. Always make sure the grinder is firmly secured to the tool post stud so that there is no side-to-side or up-and-down movement.

6. Use the tool post nut or lock lever to firmly secure the grinder in place, as shown in **Figure 7**.

Note: The tool post mounting hole of the grinder will accept tool post studs up to 1" in diameter. However, if the diameter or height of your tool post stud allows for side-to-side or up-and-down movement of the grinder when the nut is fully tightened, you will need to fabricate a custom bushing for the tool post.

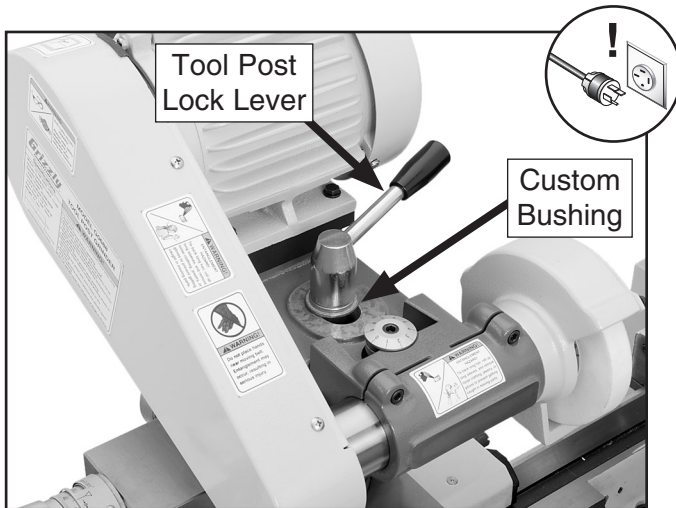

Figure 7. Tool post nut and example of a bushing.

7. When you connect the grinder to power, make sure the power cord is positioned away from any moving parts and does not pose an entanglement hazard.

Adjusting Grinder Spindle Centerline

When using the external grinding wheel, the spindle centerlines of the grinder and lathe must be at the same height to avoid damage to the wheel guard or the workpiece (see **Figure 5** on **Page 12**).

The height of the grinder spindle centerline can be adjusted between 1⁵/₈" and 2⁵/₈" above the top surface of the tool post base.

Tools Needed	Qty
Wrench 18mm	1
Hex Wrench 6mm.....	1

To adjust the grinder spindle centerline height:

1. DISCONNECT LATHE AND GRINDER FROM POWER!
2. Loosen the hex bolt on the left of the spindle housing (see **Figure 8**).

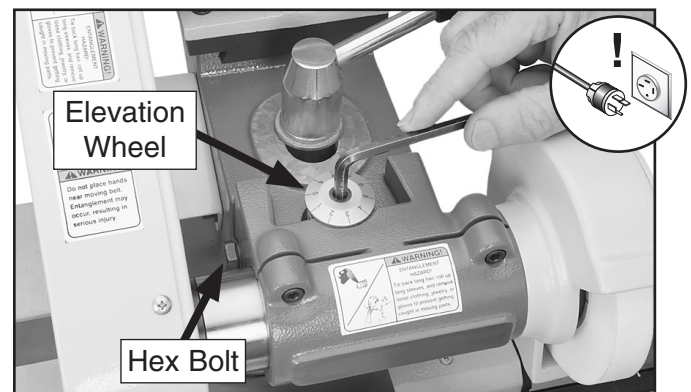

Figure 8. Adjusting the spindle centerline height.

3. Use the hex wrench to rotate the elevation wheel and change the height of the spindle centerline. Counterclockwise rotation will raise the spindle.

Note: The numerical increments on the elevation wheel are for your reference only and do not indicate the actual height of the spindle.

4. When you are satisfied with the adjustment, re-tighten the hex bolt to secure the setting.



Test Run

Once the grinder is properly mounted on your lathe and the spindle centerline is correctly adjusted, test run your machine to make sure it runs properly.

If, during the test run, you cannot easily locate the source of an unusual noise or vibration, stop using the machine immediately, then review the **Troubleshooting** on **Page 31**.

If you still cannot remedy a problem, contact our Tech Support at (570) 546-9663 for assistance.

When you have successfully completed the **Test Run**, your grinder is ready for operation.

To test run the machine:

1. Make sure you have read the safety instructions at the beginning of the manual.
2. Make sure the grinder is properly and firmly installed on your lathe, and the grinder spindle centerline is correctly adjusted, as instructed in the previous subsections.
3. Turn the grinder **ON**, then listen to and watch for abnormal noises or actions. The machine should run smoothly with little or no vibration or rubbing noises.
 - Strange or unusual noises should be investigated and corrected before operating the machine further. Always disconnect the machine from power when investigating or correcting potential problems.
4. Turn the grinder **OFF**.
5. As the wheel comes to a complete stop, note the rotation direction.
 - If the wheel rotates in the opposite direction from the arrow on the belt guard (or up and away from the operator), the motor is wired out-of-phase. Disconnect the grinder from power and switch any two hot leads inside the plug housing.



SECTION 4: OPERATIONS

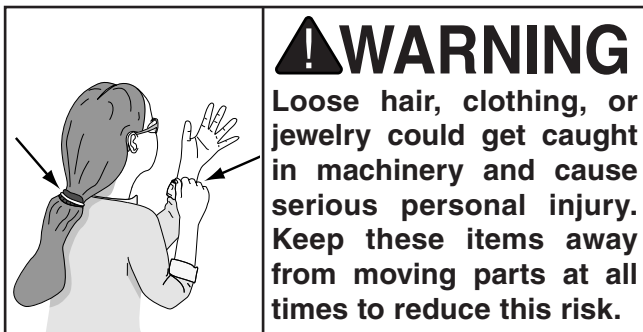
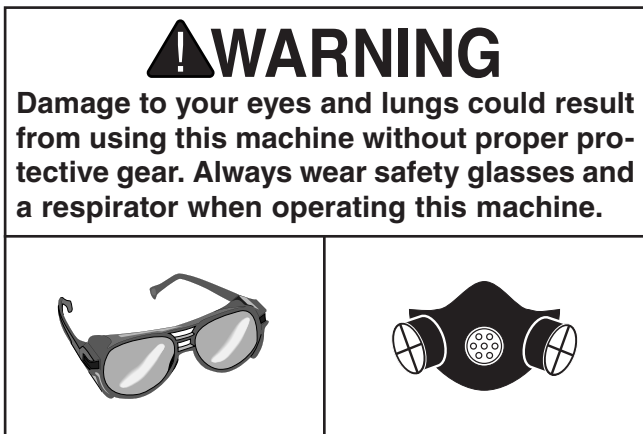
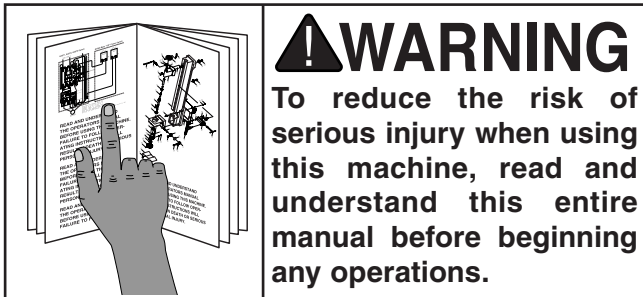

Operation Overview

This overview gives you the basic process that happens during a typical operation with this machine. Familiarize yourself with this process to better understand the remaining parts of the **Operation** section.

To complete a typical operation, the operator does the following:

1. Examines the workpiece to make sure it is suitable for grinding.
2. Properly secures the workpiece to the lathe.
3. Correctly installs the grinding wheel (external or internal) that is correct for the operation.
4. Makes sure the tool grinder setup is correct, and that all adjustment hardware is firmly tightened.
5. Starts the lathe.
6. If necessary, begins the flow of coolant to the workpiece.
7. Turns the tool post grinder and lathe **ON**.
8. Using the lathe slide controls, slowly eases the grinding wheel into the workpiece and across the surface.
9. When the operation is complete, turns the lathe and grinder **OFF**.



Lathe Rotation

To produce the best results, set the lathe speed as slow as possible without causing friction damage to the workpiece.

In addition, set the spindle rotation of the lathe so that its speed adds to that of the grinder. For the external wheel, the lathe should rotate clockwise, as illustrated in **Figure 9**. When using the internal wheel, set lathe rotation to counterclockwise.

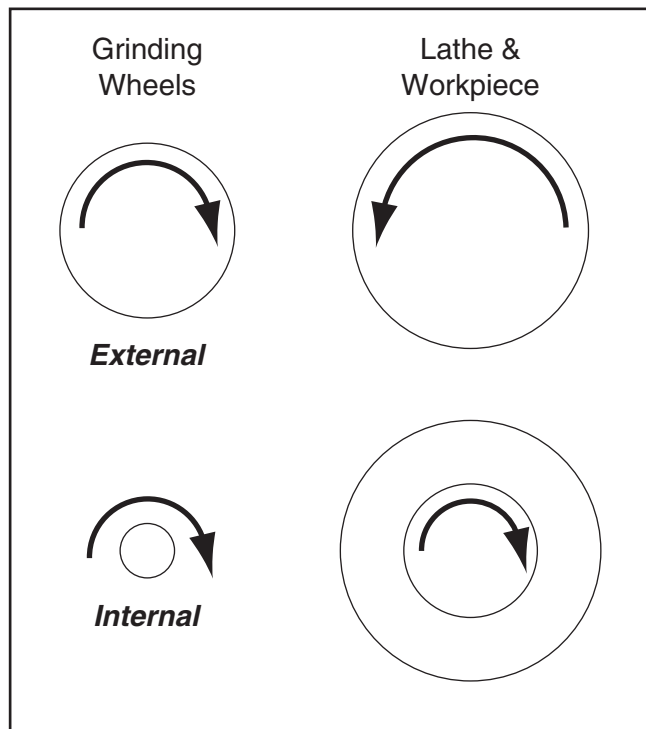

Figure 9. Correct lathe rotations.

Internal Wheel

The internal grinding wheel is used on the inside surfaces of a concentric workpiece. To configure the grinder for this type of operation, you will need to remove the external wheel, if installed, attach the internal wheel, and change the spindle pulley and belt.

Tools Needed

	Qty
Hex Wrench 5mm.....	1
Wrench 12mm	1
Wrench 18mm	1
Wrench 21mm	1
Phillips Screwdriver #2	1
Standard Screwdriver #2.....	1
Puller Tool.....	1

Removing External Wheel

1. DISCONNECT LATHE AND GRINDER FROM POWER!
2. If installed, remove the belt guard to access the right-hand spindle, as shown in **Figure 10**.

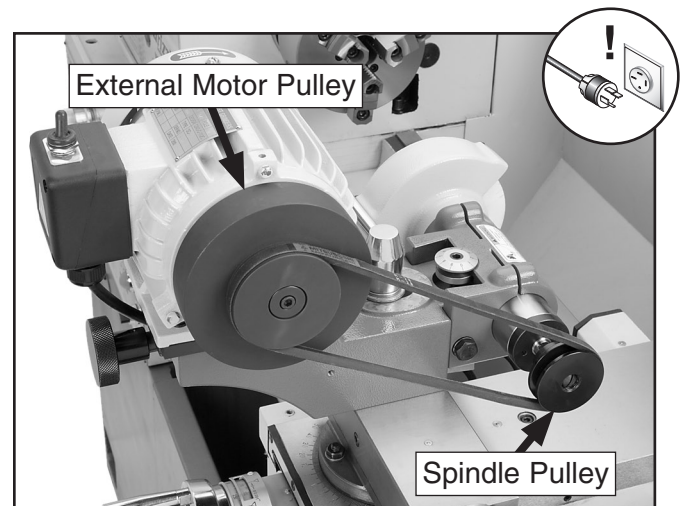
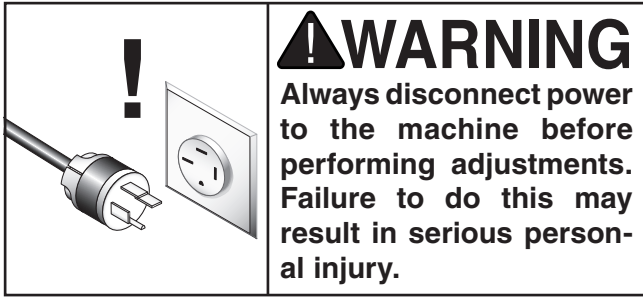

Figure 10. Belt guard removed.





3. Remove the screws and flat washers securing the external wheel guard cover, then remove the cover to expose the wheel spindle nut, as shown in **Figure 11**. Store the wheel guard, screws, and flat washers in a dry, protected location for later use.

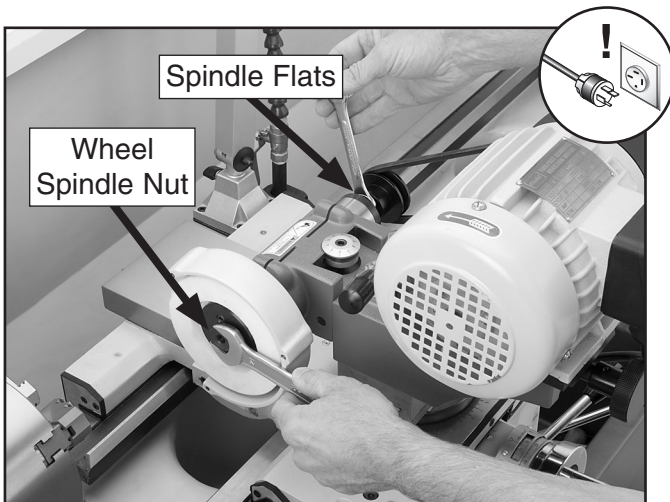

Figure 11. Removing the external wheel spindle nut.

4. Use a wrench on the flats of the right-hand spindle to keep it from turning, then unthread and remove the external wheel spindle nut, as shown in **Figure 11**.
5. While keeping the spindle from rotating, thread the puller tool into the center of the wheel flange assembly, then tighten it until the flange assembly releases from the spindle taper (see **Figure 12**).

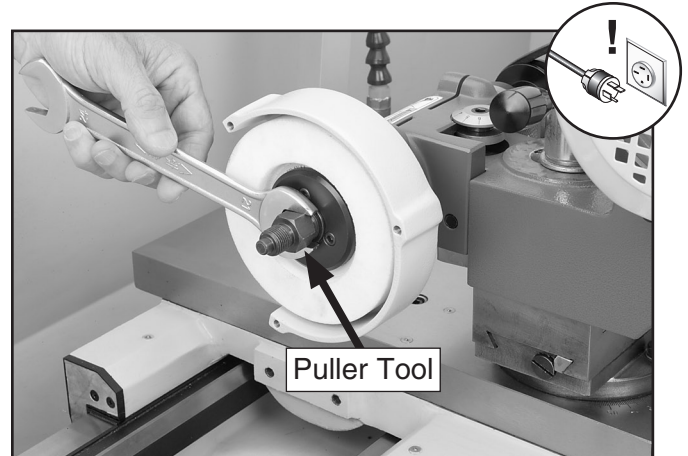

Figure 12. Using the puller tool to release the wheel assembly.

6. Store the external wheel assembly in a dry, protected area away from extreme temperatures for later use.



Installing Internal Wheel

1. DISCONNECT LATHE AND GRINDER FROM POWER!
2. If installed, remove the belt guard to access the right-hand spindle.
3. Examine the internal wheel. If there are cracks, damage, or it is worn down to $\frac{1}{2}$ of its original diameter, replace it with a new one (refer to **Accessories** on **Page 27** for a replacement option).
4. Use a wrench on the flats of the right-hand spindle to keep it from turning, then fully tighten the internal wheel onto the left-hand spindle, as shown in **Figure 13**.

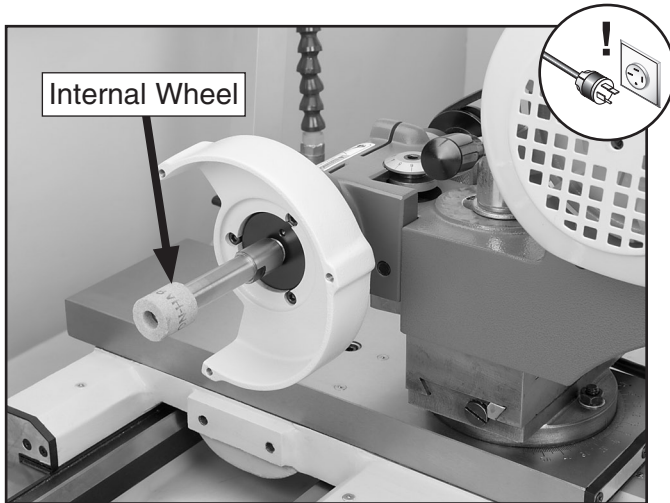

Figure 13. Internal grinding wheel installed.

Changing Spindle Pulley & Belt

1. DISCONNECT LATHE AND GRINDER FROM POWER!
2. If installed, remove the belt guard to fully expose the V-belt.

3. Loosen the two cap screws on the right side of the grinder base so that the motor mount can slide along the dovetail way (see **Figure 14**).

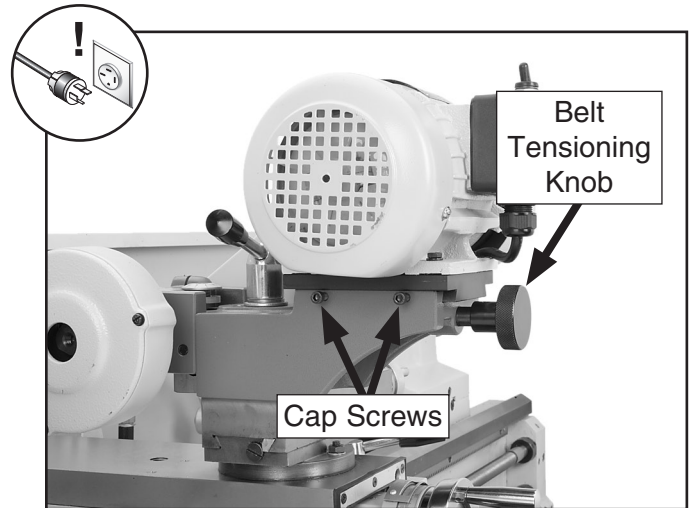

Figure 14. Belt tensioning controls.

4. Turn the belt tensioning knob to move the motor assembly forward toward the grinder spindle, then roll the V-belt off the pulleys and store it in a dry, protected area for later use.
5. Turn the spindle pulley screw shown in **Figure 15** clockwise to remove it and the flat washer from the spindle.

Note: The spindle pulley screw has left-hand threads.

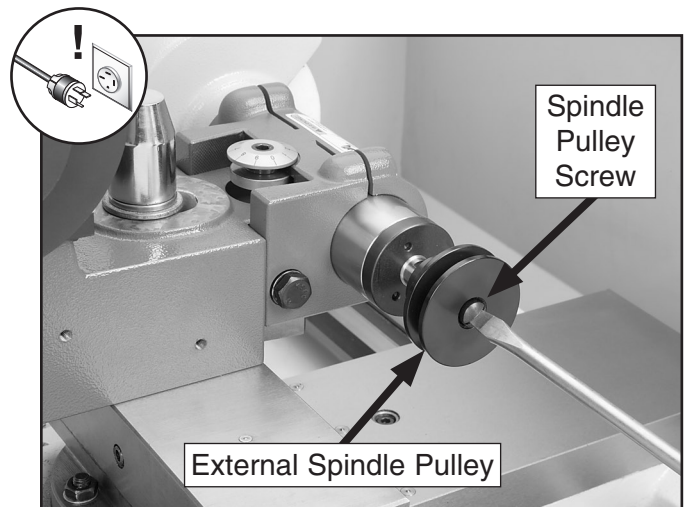

Figure 15. Removing the spindle pulley screw.



- Use the puller tool as described in **Step 5** on **Page 17** to release the external pulley from the spindle taper (see **Figure 16**), then remove the pulley.

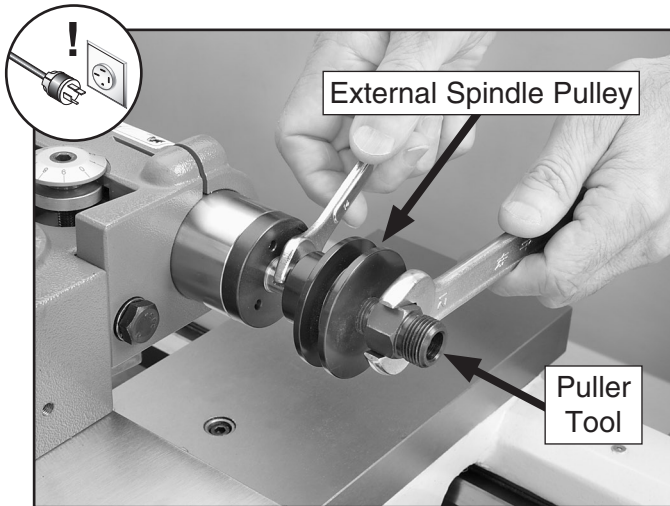

Figure 16. Removing the external spindle pulley.

- Clean any debris or oily substances from the spindle taper and the inside taper of the internal pulley.

Note: *If the tapered mating surfaces are not thoroughly clean, it could be extremely difficult to remove the pulley.*

- Slide the internal pulley onto the right-hand spindle, then secure it in place with the spindle screw and flat washer removed in **Step 5**.

Note: *There are two internal spindle pulleys—the larger one is for a grinder spindle speed of 16,500 RPM, and the smaller one is for a speed of 23,000 RPM. Use the one that best fits your operation.*

- Loosen the two cap screws shown in **Figure 17** that secure the quill, then push the quill into the housing to align the internal spindle pulley with the large, flat internal motor pulley.

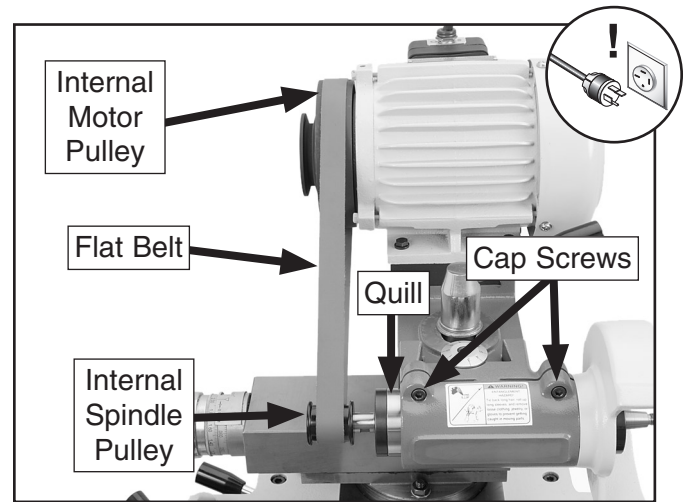

Figure 17. Aligning the internal spindle and motor pulleys.

- Place the flat belt onto the pulleys, as shown in **Figure 17**.

Note: *Use the belt tensioning knob to adjust the belt tension just enough so that it stays on the pulleys when rotated.*

- Rotate the motor pulley by hand several times to make sure that belt is tracking properly in the middle of the pulleys, then re-tighten the two cap screws that you loosened in **Step 9**.

—If the belt is not tracking properly, move the spindle pulley in or out until it does.



- Turn the belt tensioning knob to move the motor assembly back until the belt is properly tensioned.

Note: For the V-belt and the flat belt, the proper amount of tension is reached when the belt deflects approximately 1/2" with moderate pressure applied midway between the pulleys, as shown in **Figure 18**.

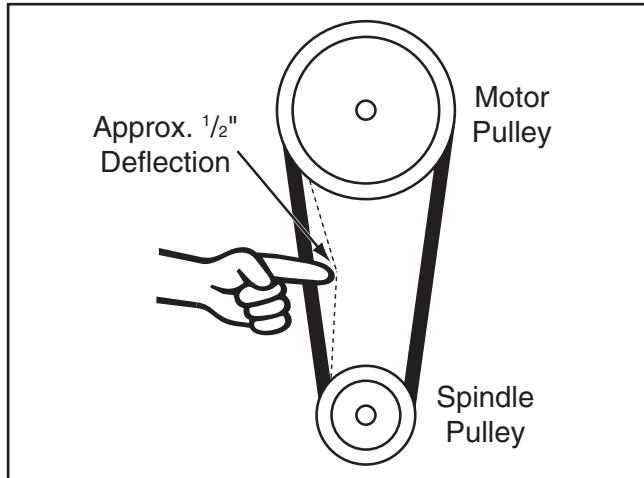

Figure 18. Checking for correct belt tension.

- When you are satisfied with the belt tension, re-tighten both cap screws that you loosened in **Step 3**.

⚠ WARNING

The belt and pulleys represent serious entanglement hazards! **ALWAYS** make sure the belt guard is properly installed before connecting the grinder to power.

- Re-install the belt guard.

External Wheel

The external grinding wheel is used to grind the outside surfaces of a concentric workpiece. To configure the grinder for this type of operation, you will need to remove the internal wheel, if installed, attach the external wheel, and change the spindle pulley and belt.

Note: To install the external wheel, you perform similar steps when installing the internal wheel. Use the photos in the previous **Internal Wheel** subsection beginning on **Page 16** for visual reference.

Tools Needed	Qty
Hex Wrench 5mm.....	1
Wrench 12mm	1
Wrench 18mm	1
Wrench 21mm	1
Phillips Screwdriver #2	1
Standard Screwdriver #2.....	1
Puller Tool.....	1

Removing Internal Wheel

- DISCONNECT LATHE AND GRINDER FROM POWER!
- If installed, remove the belt guard to access the right-hand spindle.
- Use a wrench on the flats of the right-hand spindle to keep it from turning, then unthread and remove the internal wheel (see **Figure 11**).

Note: If necessary, also use a wrench on the flats of the internal wheel shaft to loosen it.

- Store the internal wheel in a dry, protected area away from extreme temperatures for future use.



Installing External Wheel

1. DISCONNECT LATHE AND GRINDER FROM POWER!
2. Inspect the condition of the external wheel and perform the ring test, as described in the **Wheel Inspection & Ring Test** subsection on **Page 25**.

—If the external wheel is damaged or is worn down to $\frac{1}{2}$ of its original diameter, replace it (refer to the **External Wheel Flange** subsection on **Page 22** for detailed instructions to remove the flange and install it onto the new wheel). Then, balance the wheel, as described in the **Balancing External Wheel** subsection on **Page 23**.

3. If installed, remove the belt guard to access the right-hand spindle.
4. Thoroughly clean the tapered mating surfaces of the wheel flange and the left-hand spindle, then slide the wheel onto the spindle.
5. To secure the wheel, use a wrench on the flats of the right-hand spindle to keep it from rotating, then thread the wheel spindle nut onto the left-hand spindle until it is snug.

Note: Do not overtighten the wheel nut—this would make it very difficult to remove the wheel.

WARNING

The external grinding wheel represents a serious entanglement hazard! ALWAYS make sure the wheel guard is properly installed before connecting the grinder to power.

6. Attach the cover onto the external wheel guard.

Changing Spindle Pulley & Belt

1. DISCONNECT LATHE AND GRINDER FROM POWER!
2. If installed, remove the belt guard to fully expose the flat belt.
3. Loosen the two cap screws on the right side of the grinder base so that the motor mount can slide along the dovetail way, then use the belt tensioning knob to move the motor assembly forward toward the spindle (see **Figure 14**).

4. Remove the flat belt from the pulleys and store it in a dry, protected area for later use.

Note: If the belt is damaged or excessively worn, replace it with a new one.

5. Turn the spindle pulley screw clockwise to remove it and the flat washer from the spindle (see **Figure 15**).

Note: The spindle pulley screw has left-hand threads.

6. While keeping the spindle from rotating, thread the puller tool into the center of the internal spindle pulley, then tighten it until the pulley releases from the spindle taper (see **Figure 12**).

7. Thoroughly clean the tapered mating surfaces of the external spindle pulley and the spindle, then slide the pulley onto the spindle.

8. Secure the pulley with the spindle screw and flat washer removed in **Step 5**.

9. Roll the V-belt onto the pulleys, then use the belt tensioning knob to properly tension the V-belt.

Note: The proper amount of tension is reached when the belt deflects approximately $\frac{1}{2}$ " with moderate pressure applied midway between the pulleys (see **Figure 18**).



- When you are satisfied with the belt tension, re-tighten both cap screws that loosened in **Step 3**.

⚠️ WARNING

The belt and pulleys represent serious entanglement hazards! **ALWAYS** make sure the belt guard is properly installed before connecting the grinder to power.

- Re-install the belt guard.

External Wheel Flange

The external wheel uses a two-part wheel flange to properly secure it to the grinder spindle. This flange is also used to balance the wheel assembly for safe and accurate rotation, which must be performed when attaching the flange to a new wheel (refer to **Balancing External Wheel** on **Page 23** for detailed instructions).

The external wheel flange assembly consists of a rear flange, front flange, and three cap screws that secure the flanges together, as shown in **Figure 19**.

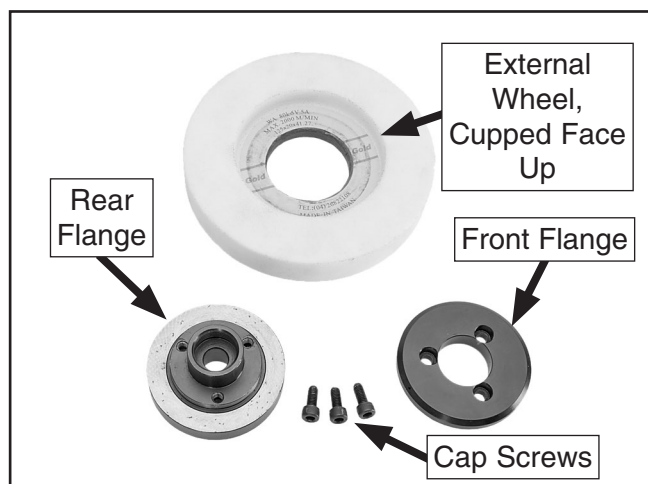

Figure 19. Components of the external flange assembly.

Tools Needed	Qty
Hex Wrench 4mm.....	1

To attach the external wheel flange to a new wheel:

- Lay the old external wheel on a flat surface and remove the three cap screws shown in **Figure 20**.



Figure 20. Flange assembly cap screws.

- Separate the front flange from the rear flange, as shown in **Figure 21**.

Note: *The front and rear flanges use tapered surfaces to mate and align to each other.*

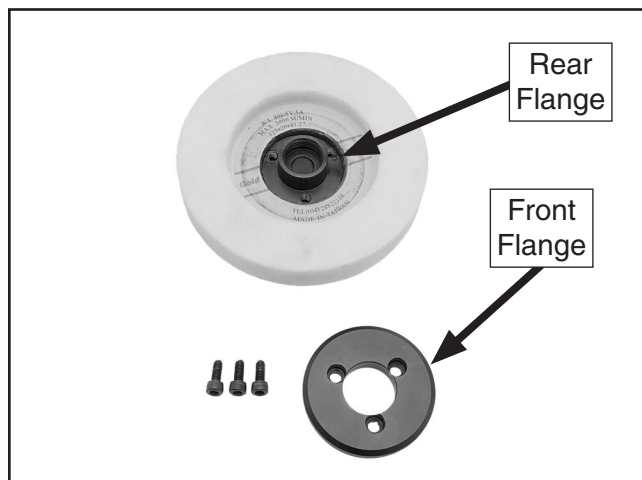

Figure 21. Front flange removed.



3. Remove the rear flange from the wheel, then use a shop rag and mineral spirits to clean both flanges. Make sure to remove all debris from the tapered mating surfaces to ensure a clean fit.
4. Perform the **Wheel Inspection & Ring Test** procedure on **Page 25**. If you have any doubt about the condition of the wheel, **DO NOT** use it!
5. Lay the rear flange flat and insert the new external wheel over it so that the cupped recess of the wheel is pointing up.
6. Insert the taper of the front flange into that of the rear flange, then align and thread the three cap screws into the flange assembly until they are just snug.

Note: To avoid cracking the wheel, **DO NOT** overtighten the cap screws.

7. Perform the following **Balancing External Wheel** procedure.

Balancing External Wheel

A properly balanced external grinding wheel helps to ensure a good grinding finish and reduces stress on the grinder. Checking or adjusting the wheel balance is a simple process and one that **MUST** be performed for new wheels before mounting them on the grinder.

You will need two metal bars of equal sizes with top edges that are as thin as possible (see **Figure 22** for an example), which will be used as a platform for the wheel.

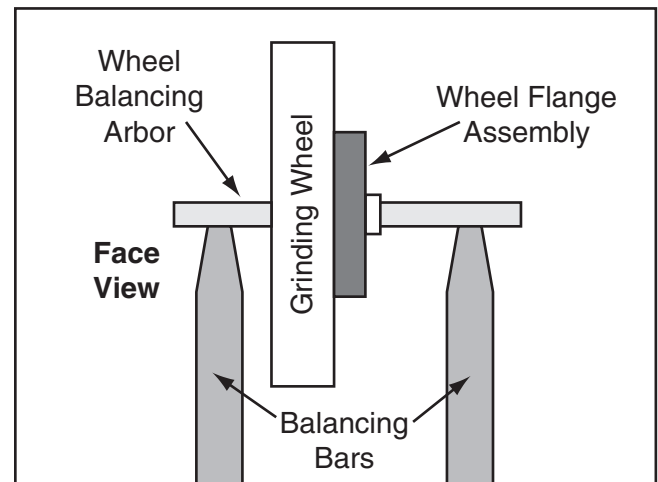

Figure 22. Side illustration of a typical wheel balancing setup.

Tools Needed	Qty
Hex Wrench 2.5mm.....	1
Wheel Balancing Arbor	1
Balance Bars	2
Chalk	1 Piece

To balance the external grinding wheel:

1. Make sure the wheel flange assembly is properly installed on the wheel.
2. Make sure the balancing bars are level and of the same height.



3. Remove the three wedge shaped balancing weights from the rear wheel flange (see **Figure 23**).

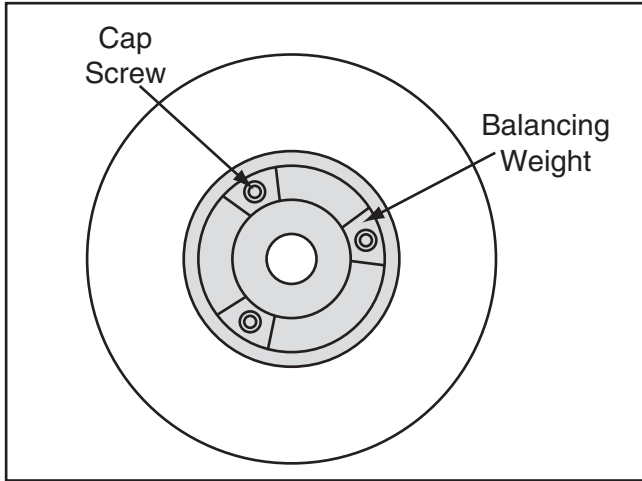

Figure 23. Balancing weights of the wheel flange.

4. Insert the balancing arbor into the wheel flange center, place the wheel on the balancing bars so that the arbor extends equally over the bars, as shown in **Figure 22**.
5. Rotate the wheel 90°, then release it. Allow the wheel to rotate by itself and come to a complete stop, then use chalk to mark the top center of the wheel flange and install one balancing weight at that point.

Note: *The chalk mark is the point directly opposite the heaviest part of the wheel at the bottom.*

6. Install the remaining two weights so that they are an equal distance from the first weight and each other, as shown in **Figure 23**.
7. Repeat **Step 4**, then rotate the wheel 90°.

—If the wheel turns by itself after you rotate it 90° on the bars, it is still out of balance. Change the positions of the last two weights installed in small increments until the wheel no longer rotates on its own when placed on the balancing bars.

Wheel Care

When grinding, your safety depends, in a large part, on the condition of the grinding wheel during operation. A wheel in poor condition increases the risk of it flying apart during operation and injuring the operator or causing property damage.

Follow these rules to reduce the risk of breaking the wheel:

- Always transport, store, and handle wheels with care. Wheels could be damaged if they are dropped or if heavy objects are stacked on them.
- Select the right grinding wheel for the job. Attempting to use an external wheel for an internal grinding operation, or vice versa, will not work and will increase the risk of personal injury and property damage.
- Mount the wheels properly and make sure they are secure on the grinder spindles.
- Do not abuse the wheel by jamming it into the workpiece with excessive force or by allowing the workpiece to become overly hot during the operation.
- Do not store wheels in a location with extreme temperatures that will damage the bonding material.
- Replace the wheel when it becomes less than $\frac{1}{2}$ of its original diameter.
- Use only the pulley and wheel mounting hardware that is included with your grinder.
- To ensure good grinding results, dress the wheel before each use (refer to **Wheel Dressing** on **Page 26** for detailed instructions).
- Always visually inspect each wheel, and perform the ring test on the external wheel before installing it (refer to **Wheel Inspection & Ring Test** on **Page 25** for detailed instructions).



Wheel Inspection & Ring Test

Do not assume that a grinding wheel is in sound condition just because it is new or looks okay. Often damage can occur in shipping, storage, or with age, and may not be visible. Inspect every wheel for damage before installation.

For both the internal and external grinding wheels, do a visual inspection. Look for any cracks, chips, nicks or dents in the surface of the wheel. If you see any of these, DO NOT use the wheel!

For the external wheel only, do a ring test. This test will give you an indication of any internal damage that may not be obvious during a visual inspection. If the wheel does not pass the ring test, DO NOT use the wheel!

To perform a ring test:

1. Make sure the wheel that you test is clean and dry—otherwise, you may get false results.
2. If size permits, balance the wheel with your finger in the center hole. If this is not possible, hang the wheel in the air with a piece of cord or string looped through the center hole.

3. At the four spots on the wheel shown in **Figure 24**, gently tap the wheel with a non-metallic object, such as a screwdriver handle or wooden mallet.

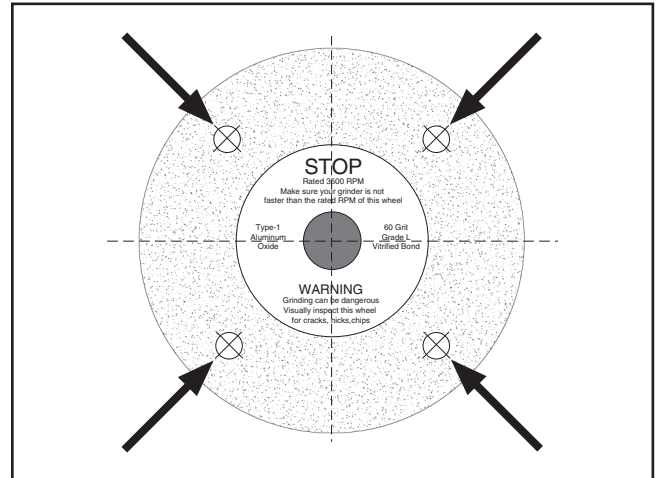

Figure 24. Tapping locations for a ring test.

4. An undamaged wheel will emit a clear metallic ring or “ping” sound in each of the four spots. A damaged wheel will respond with a dull thud that has no clear tone.

—If you determine from the results of the ring test that the wheel is damaged, DO NOT use it!



Wheel Dressing

With use, the surface of the grinding wheel will fill with metal residue and grit. When this happens, the wheel needs to be cleaned or “dressed.” The goal of dressing the wheel is to remove the contaminants and make the grinding surface even and flat to ensure good grinding results.

Tools Needed	Qty
Hex Wrench 5mm.....	1
Wrench 1 ¹ / ₁₆ "	1

To use the included diamond dress tool and holder:

1. DISCONNECT LATHE AND GRINDER FROM POWER!
2. Clamp the tool holder to a stationary device, such as a chuck jaw, so that it is perpendicular to the grinding surface of the wheel (see **Figure 25** for a typical setup).



Figure 25. An example of the diamond dresser tool and holder mounted on a chuck jaw

⚠ CAUTION

Grinding wheels have the capability of removing a lot of skin quickly. Make sure the dresser tool and holder are firmly secured in place and keep your hands a safe distance away from the spinning wheel.

3. Secure the dresser tool into the holder, then position the wheel so that the dresser tool is to one side of the wheel surface and just touching it.
4. Connect the grinder to power and turn it **ON**, then move the wheel back-and-forth across the dresser tool.
5. Adjust the cross slide to make multiple light passes with the wheel until you are satisfied with the condition of the wheel surface.

Note: *Several light passes across the dressing tool will produce the best results, with the least amount of wear or damage to the wheel or the dressing tool.*



SECTION 5: ACCESSORIES

- T20930—Replacement External Wheel
- T20931—Replacement Internal Wheel

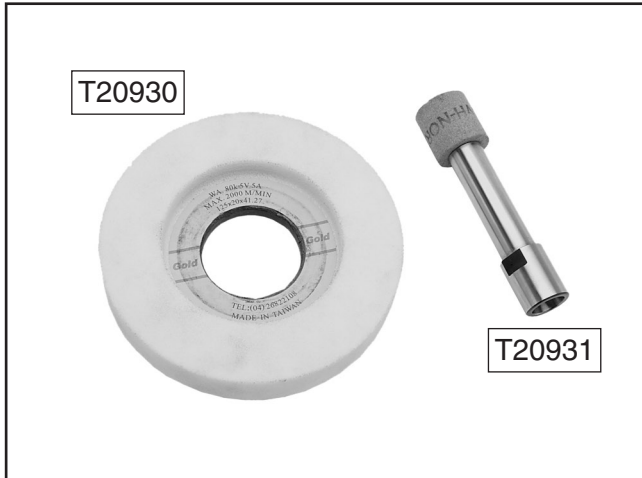

Figure 26. Replacement wheels for the Model G0668 Tool Post Grinder.

- T20501—Face Shield Crown Protector 4"
- T20502—Face Shield Crown Protector 7"
- T20503—Face Shield Window
- T20452—"Kirova" Anti-Reflective S. Glasses
- T20451—"Kirova" Clear Safety Glasses
- H0736—Shop Fox® Safety Glasses
- H7194—Bifocal Safety Glasses 1.5
- H7195—Bifocal Safety Glasses 2.0
- H7196—Bifocal Safety Glasses 2.5



Figure 27. Eye protection assortment.

Call 1-800-523-4777 To Order

- H2499—Small Half-Mask Respirator
- H3631—Medium Half-Mask Respirator
- H3632—Large Half-Mask Respirator
- H3635—Cartridge Filter Pair P100

Wood dust has been linked to nasal cancer and severe respiratory illnesses. If you work around dust everyday, a half-mask respirator can be a lifesaver. Also compatible with safety glasses!



Figure 28. Half-mask respirator with disposable cartridge filters.

- G5562—SLIPIT® 1 Qt. Gel
- G5563—SLIPIT® 12 oz Spray
- G2871—Boeshield® T-9 12 oz Spray
- G2870—Boeshield® T-9 4 oz Spray
- H3788—G96® Gun Treatment 12 oz Spray
- H3789—G96® Gun Treatment 4.5 oz Spray



Figure 29. Recommended products for protecting unpainted cast iron/steel part on machinery.



H4380—8" Buffer

This heavy-duty unit features large diameter extended shafts for buffing and polishing. Bearings are lubricated for long life. Motor is ½ HP, 110V, single-phase. Buffing wheels not included.



Figure 30. H4380 8" Buffer.

Quick Change Tool Post Sets

G5689—For Lathes w/10" Swing

G5690—For Lathes w/12"-14" Swing

G5691—For Lathes w/13"-15" Swing

G9710—For Lathes w/14"-20" Swing

Speed up your lathe operations and enjoy the convenience of easy tool set up with these Quick Change Tool Post Sets. Tool posts feature a piston-type mechanism and come with five tool holders including: turning holder, knurling/turning holder, parting tool holder, boring bar holder, and boring/turning holder. All milled surfaces are hardened and precision-ground for repeatable accuracy. Each set comes with a blank T-nut which requires machining to fit your lathe.



Figure 31. Quick Change Tool Post Sets.

G0686—Large Drill Bit Grinder

This unique grinder will make quick work of all your large drill bit sharpening needs. Quickly set the drill angle from 50°–150° with the easy to read scale. Slip in a drill bit and adjust the tailstock center. Adjust the drill bit and hold it in place with an adjustable flute pin. Advance the drill bit into the bore of the rotating grinding wheel with the calibrated handwheel and precision swing arm, and you're ready to put beautifully finished cutting edges on all of your large drill bits.



Figure 32. G0686 Large Drill Bit Grinder.

Diamond Dressers

H5891—¼ Carat

H5892—¾ Carat

Industrial diamond for dressing grinding wheels. 8¼" long round body with knurled grip for maximum control. Includes protective rubber end cap.

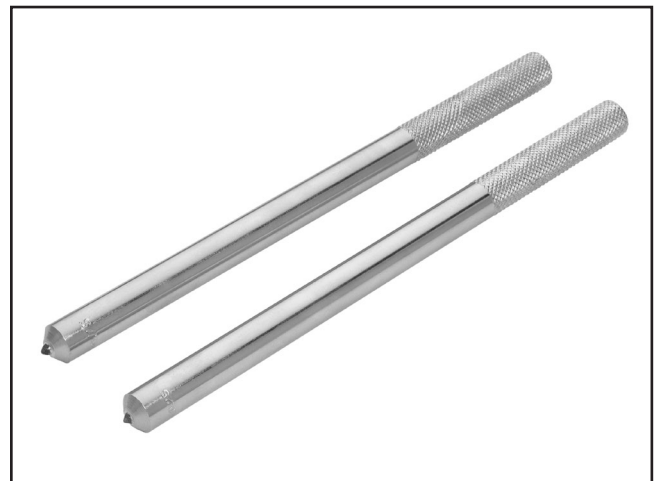

Figure 33. Diamond dressers.

grizzly.com[®]
TOOL WEBSITE



T10118—Tailstock Digital Readout

Here's the slickest setup for managing the depth of cut with your tailstock. Just set up, touch off and zero out! You're going to know the exact position of the tool. Both the scale display and remote display come with a 0.0005" (five ten-thousandths of an inch) resolution, inch or millimeter display, zero keys and ON/OFF keys. The scale has an 8" range and its display features ABS or INC mode as well as a Hold key. Both displays read independently of each other, too! You'll be able to see your depth at a glance with the large, 1/2" character remote display. The 6' data cable is long enough to mount the remote display in almost any convenient location.



Figure 34. T10118 Tailstock Digital Readout.

grizzly.com[®]
TOOL WEBSITE

Six-Jaw, High-Precision Run True Scroll Chucks

G9856—6" Diameter, 1.53" Bore

G9857—8" Diameter, 2.26" Bore

G9858—10" Diameter, 2.83" Bore

"Run True" Chucks are the best chucks you can buy. Every part is machined to precise tolerances and repeatable concentricity is maintained. Unique micro adjustment feature enables repeatable accuracy to within 0.0005". Scroll and jaws are hardened and ground. Includes 2-piece jaws. These chucks feature semi-steel bodies and self-centering jaws. Requires a mounting plate.



Figure 35. Run True Chuck.



SECTION 6: MAINTENANCE

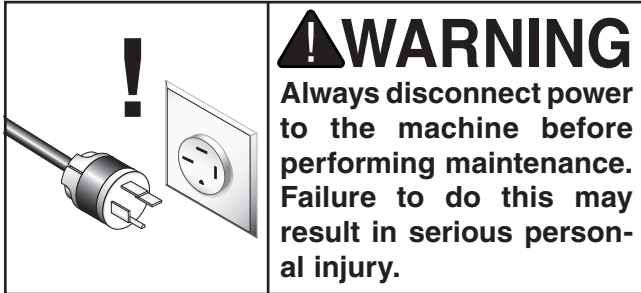

Schedule

For optimum performance from your machine, follow this maintenance schedule and refer to any specific instructions given in this section.

Daily Maintenance:

- Check/re-tighten loose mounting bolts.
- Check wheels for damage (**Page 25**).
- Dress wheels (**Page 26**).
- Check/repair worn or damaged wires.
- Clean and lubricate machine.
- Resolve any other unsafe condition.

Cleaning & Protecting

Cleaning the Model G0688 is relatively easy. Vacuum metal chips, and wipe off the remaining grit with a dry cloth.

Protect the unpainted cast iron surfaces and keep them rust-free with regular applications of products like G96® Gun Treatment, SLIPIT®, or Boeshield® T-9 (see **Section 5: Accessories** on **Page 27** for more details).

Lathe Bedway

The grinding operation generates extremely abrasive dust particles that will wear the exposed metal-to-metal moving parts of the lathe. When you are finished with the grinding operation and have removed the Model G0688 from your lathe, clean these exposed surfaces and relubricate them.

NOTICE

To avoid damaging wear to the exposed lathe metal-to-metal moving lathe parts, thoroughly clean and re-lubricate them after grinding operations.

Lubrication

The bearings of the Model G0668 are factory lubricated and sealed, and they require no attention unless they need replacement.

Remove the belt from the spindle pulley, then loosen the two cap screws that secure the quill (see **Figure 36**). Move the quill back-and-forth and clean away any debris and grit, then apply a thin coat of light machine oil to the outside surface of the quill.

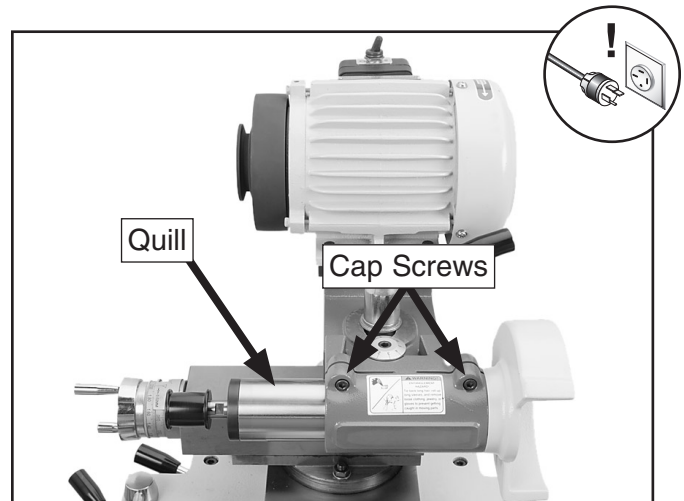

Figure 36. Lubricating the quill.



SECTION 7: SERVICE

Review the troubleshooting and procedures in this section to fix or adjust your machine if a problem develops. If you need replacement parts or you are unsure of your repair skills, then feel free to call our Technical Support at (570) 546-9663.

Troubleshooting

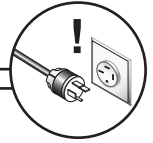

Motor & Electrical

Symptom	Possible Cause	Possible Solution
Machine does not start or a breaker trips.	<ol style="list-style-type: none"> 1. Power supply switched OFF or at fault. 2. Plug/receptacle at fault/wired wrong. 3. Motor connection wired wrong. 4. Wall circuit breaker tripped. 5. Wiring open/has high resistance. 6. Motor ON/OFF switch at fault. 7. Motor at fault. 	<ol style="list-style-type: none"> 1. Ensure power supply is ON/has correct voltage. 2. Test for good contacts; correct the wiring. 3. Correct motor wiring connections (Page 34). 4. Ensure circuit size is correct/replace weak breaker. 5. Check/fix broken, disconnected, or corroded wires. 6. Replace switch. 7. Test/repair/replace.
Machine stalls or is underpowered.	<ol style="list-style-type: none"> 1. Feed rate/lathe speed too fast. 2. Belt slipping. 3. Motor wired incorrectly. 4. Plug/receptacle at fault. 5. Pulley slipping on shaft/spindle. 6. Motor bearings at fault. 7. Machine undersized for task. 8. Motor overheated. 9. Motor at fault. 	<ol style="list-style-type: none"> 1. Decrease feed rate/lathe speed. 2. Tension/replace belt; ensure pulleys are aligned. 3. Wire motor correctly (Page 34). 4. Test for good contacts/correct wiring. 5. Replace loose pulley/shaft/spindle. 6. Test/repair/replace. 7. Use new grinding wheel; reduce the feed rate. 8. Clean motor, let cool, and reduce workload. 9. Test/repair/replace.
Machine has vibration or noisy operation.	<ol style="list-style-type: none"> 1. Motor or component loose. 2. External wheel contacting guard. 3. Belt worn or loose. 4. Grinding wheel at fault/arbor hole not round. 5. Pulley loose. 6. Incorrectly mounted to lathe. 7. Motor mount loose/broken. 8. Motor bearings at fault. 9. Motor shaft bent. 	<ol style="list-style-type: none"> 1. Inspect/replace damaged bolts/nuts, and re-tighten with thread locking fluid. 2. Properly align spindle pulley with motor pulley; make sure external wheel does not contact guard. 3. Inspect/replace belt. 4. Dress/replace grinding wheel. 5. Realign/replace shaft, pulley, setscrew, and key. 6. Use bushing(s); re-tighten tool post nut. 7. Tighten/replace. 8. Test by rotating shaft; rotational grinding/loose shaft requires bearing replacement. 9. Test with dial indicator and replace motor.



Operation

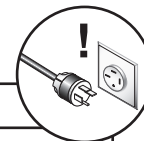

Symptom	Possible Cause	Possible Solution
Wavy pattern on workpiece surface.	<ol style="list-style-type: none"> 1. Machine vibrating. 2. Workpiece loose in clamping device. 3. Wheel face is uneven. 	<ol style="list-style-type: none"> 1. Shim/tighten mounting hardware. 2. Correctly re-clamp the workpiece. 3. Dress the wheel (Page 26).
Lines on workpiece surface.	<ol style="list-style-type: none"> 1. Impurity on wheel surface. 2. Workpiece loose in clamping device. 	<ol style="list-style-type: none"> 1. Dress the wheel (Page 26). 2. Correctly re-clamp the workpiece.
Burned spots or cracks in workpiece.	<ol style="list-style-type: none"> 1. Improper type of grinding wheel. 2. Feed rate too slow. 3. Depth of cut too great. 4. Workpiece overheating. 	<ol style="list-style-type: none"> 1. Use the correct type of grinding wheel (Page 27). 2. Increase feed rate. 3. Reduce depth of cut; take multiple light passes. 4. Grind in short durations and allow workpiece to cool in between.
Wheel dulls quickly, grit falls off.	<ol style="list-style-type: none"> 1. Depth of cut too great. 2. Wheel exposed to moisture. 3. Wheel dressed incorrectly. 4. Defective wheel bonding. 	<ol style="list-style-type: none"> 1. Reduce depth of cut; take multiple light passes. 2. Store wheel away from moisture; replace wheel. 3. Correctly dress the wheel (Page 26). 4. Replace wheel.
Wheel clogs and workpiece shows burn marks.	<ol style="list-style-type: none"> 1. Feed rate too slow. 2. Wheel dressed incorrectly. 3. Workpiece incorrect material. 	<ol style="list-style-type: none"> 1. Increase feed rate. 2. Correctly dress the wheel (Page 26). 3. Grind ferrous materials only.
Workpiece is ground unevenly.	<ol style="list-style-type: none"> 1. Workpiece not properly clamped. 2. Wheel dressed incorrectly or has impurities. 3. Wheel is damaged. 	<ol style="list-style-type: none"> 1. Properly re-clamp workpiece. 2. Correctly dress the wheel (Page 26). 3. Replace wheel; check new wheel before using (Page 25).



SECTION 8: WIRING

These pages are current at the time of printing. However, in the spirit of improvement, we may make changes to the electrical systems of future machines. Study this section carefully. If there are differences between your machine and what is shown in this section, call Technical Support at (570) 546-9663 for assistance BEFORE making any changes to the wiring on your machine.

WARNING















Wiring Safety Instructions

1. **SHOCK HAZARD.** Working on wiring that is connected to a power source is extremely dangerous. Touching electrified parts will result in personal injury including but not limited to severe burns, electrocution, or death. Disconnect the power from the machine before servicing electrical components!
2. **QUALIFIED ELECTRICIAN.** Due to the inherent hazards of electricity, only a qualified electrician should perform wiring tasks on this machine. If you are not a qualified electrician, get help from one before attempting any kind of wiring job.
3. **WIRE CONNECTIONS.** All connections must be tight to prevent wires from loosening during machine operation. Double-check all wires disconnected or connected during any wiring task to ensure tight connections.
4. **WIRE/COMPONENT DAMAGE.** Damaged wires or components increase the risk of serious personal injury, fire, or machine damage. If you notice that any wires or components are damaged while performing a wiring task, replace those wires or components before completing the task.
5. **MODIFICATIONS.** Using aftermarket parts or modifying the wiring beyond what is shown in the diagram may lead to unpredictable results, including serious injury or fire.
6. **MOTOR WIRING.** The motor wiring shown in these diagrams is current at the time of printing, but it may not match your machine. Always use the wiring diagram inside the motor junction box.
7. **CAPACITORS/INVERTERS.** Some capacitors and power inverters store an electrical charge for up to 10 minutes after being disconnected from the power source. To reduce the risk of being shocked, wait at least this long before working on capacitors.
8. **CIRCUIT REQUIREMENTS.** You MUST follow the requirements at the beginning of this manual when connecting your machine to a power source.
9. **EXPERIENCING DIFFICULTIES.** If you are experiencing difficulties understanding the information included in this section, contact our Technical Support at (570) 546-9663.

NOTICE

The photos and diagrams included in this section are best viewed in color. You can view these pages in color at www.grizzly.com.

COLOR KEY

BLACK 	BLUE 	YELLOW 	LIGHT BLUE 
WHITE 	BROWN 	YELLOW GREEN 	BLUE WHITE 
GREEN 	GRAY 	PURPLE 	TURQUOISE 
RED 	ORANGE 	PINK 	



Wiring Diagram

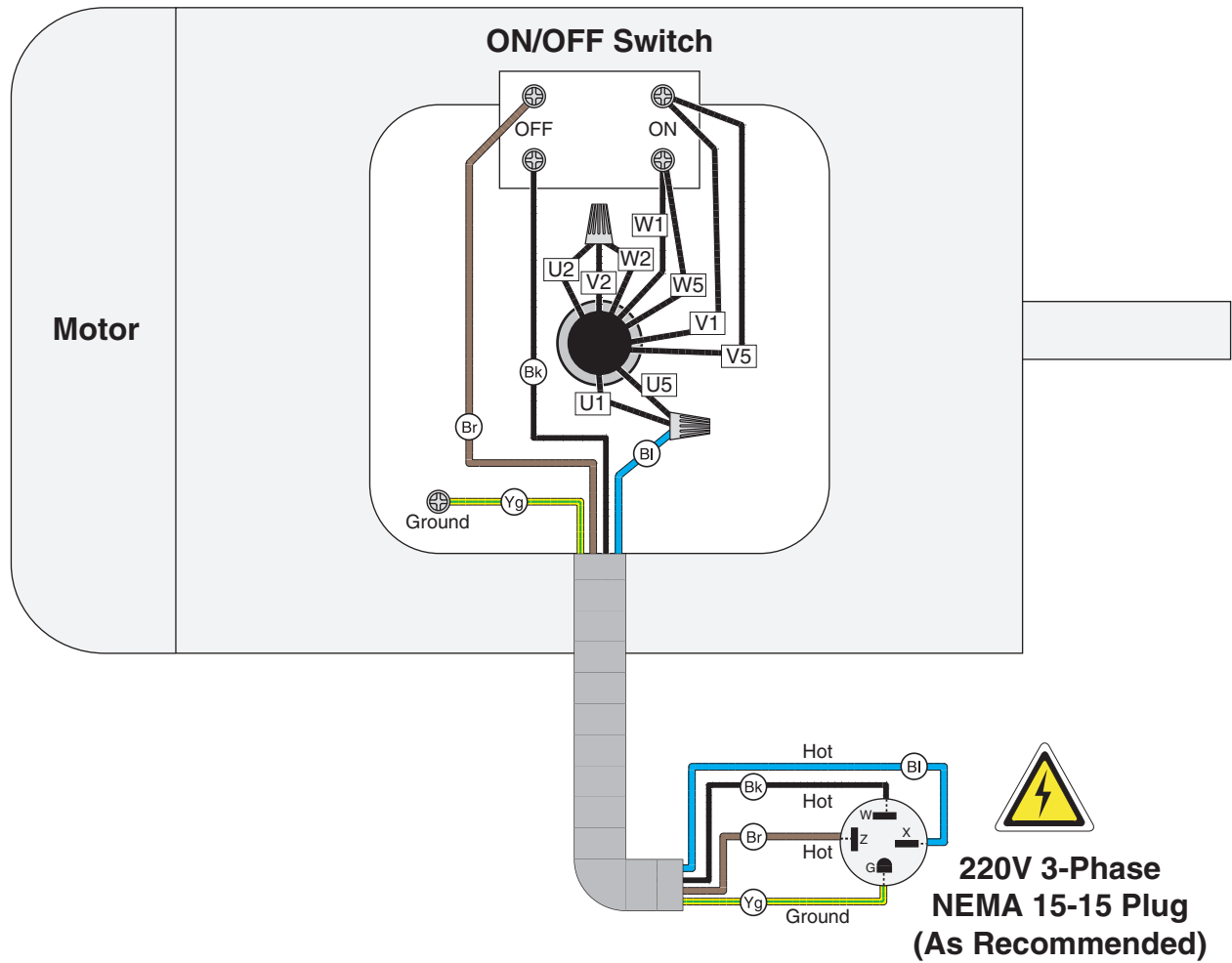
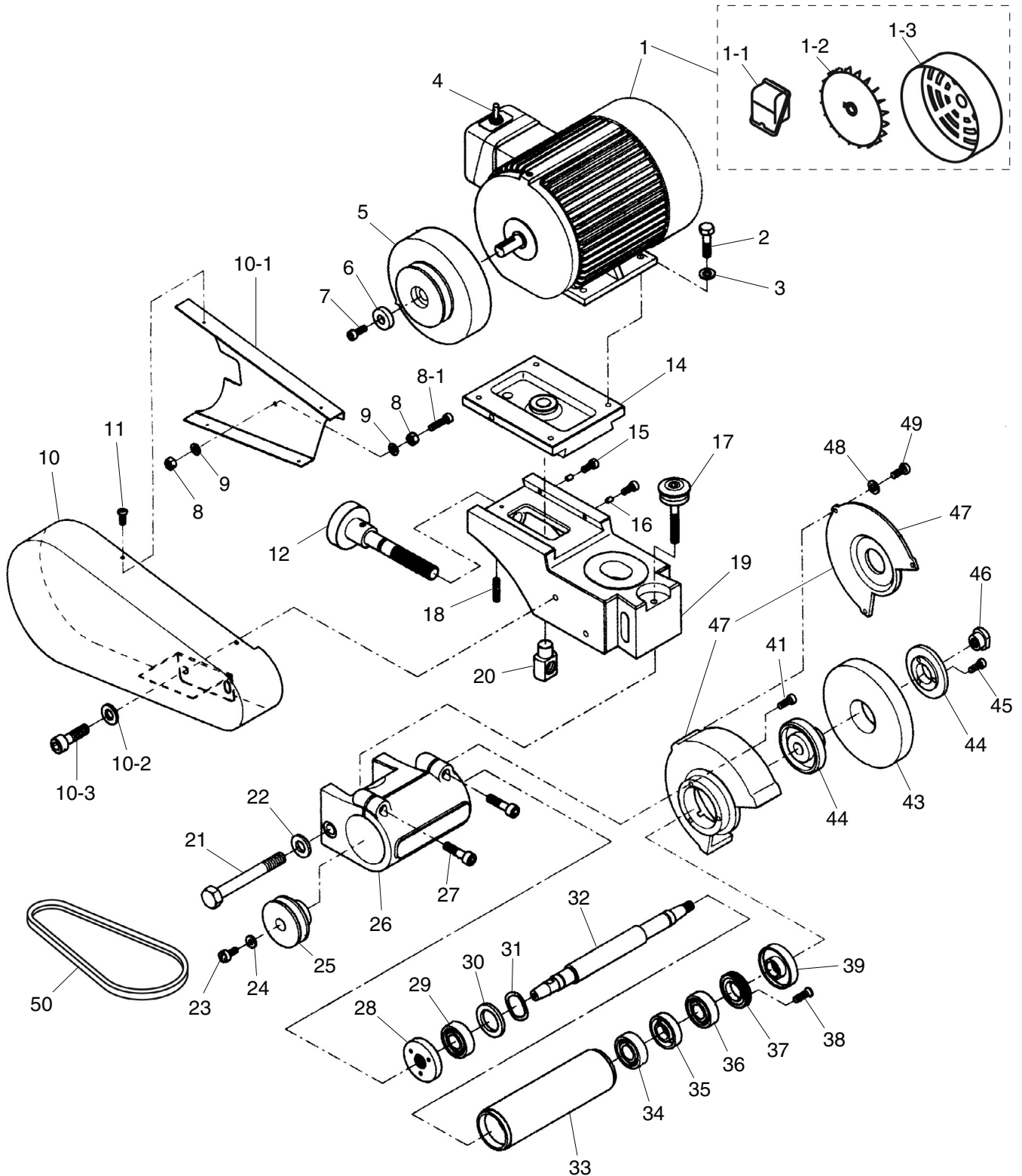

Figure 37. Model G0688 wiring.



SECTION 9: PARTS

Main Breakdown



Main Parts List

REF	PART #	DESCRIPTION
1	P0688001	MOTOR 1/2HP 220V 3-PH
1-1	P0688001-1	MOTOR WIRING JUNCTION BOX
1-2	P0688001-2	MOTOR FAN
1-3	P0688001-3	MOTOR FAN COVER
2	PB08M	HEX BOLT M6-1 X 20
3	PW03M	FLAT WASHER 6MM
4	P0688004	ON/OFF SWITCH
5	P0688005	MOTOR PULLEY
6	P0688006	SPECIAL WASHER
7	PCAP01M	CAP SCREW M6-1 X 16
8	PN06M	HEX NUT M5-.8
8-1	PS06M	PHLP HD SCR M5-.8 X 20
9	PW02M	FLAT WASHER 5MM
10	P0688010	OUTER BELT GUARD
10-1	P0688010-1	INNER BELT GUARD
10-2	PW01M	FLAT WASHER 8MM
10-3	PCAP14M	CAP SCREW M8-1.25 X 20
11	PS20M	PHLP HD SCR M4-.7 X 5
12	P0688012	BELT TENSIONING SHAFT M16-1.5
14	P0688014	MOTOR BASE
15	PCAP26M	CAP SCREW M6-1 X 12
16	P0688016	LOCK PIN
17	P0688017	ELEVATION SCREW M16-1.5
18	PRP18M	ROLL PIN 4 X 12
19	P0688019	BASE
20	P0688020	MOTOR ADJUSTING NUT M16-1.5
21	PB23M	HEX BOLT M10-1.5 X 100

REF	PART #	DESCRIPTION
22	PW04M	FLAT WASHER 10MM
23	P0688023	SPECIAL SCREW M6-1
24	P0688024	SPECIAL FLAT WASHER
25	P0688025	SPINDLE EXTERNAL PULLEY
26	P0688026	QUILL HOUSING
27	PCAP06M	CAP SCREW M6-1 X 25
28	P0688028	LEFT QUILL COVER
29	P7203	ANG CONTACT BEARING 7203
30	P0688030	SPACER
31	P0688031	WAVY WASHER
32	P0688032	SPINDLE
33	P0688033	QUILL
34	P7203	ANG CONTACT BEARING 7203
35	P0688035	SPACER
36	P7203	ANG CONTACT BEARING 7203
37	P0688037	LOCK COLLAR
38	PFH54M	FLAT HD SCR M5-.8 X 20
39	P0688039	RIGHT QUILL COVER
41	PCAP15M	CAP SCREW M5-.8 X 20
43	P0688043	EXTERNAL GRINDING WHEEL 5"
44	P0688044	EXTERNAL WHEEL FLANGE ASSY
45	PCAP33M	CAP SCREW M5-.8 X 12
46	P0688046	SPINDLE NUT M10-1.5
47	P0688047	EXTERNAL WHEEL GUARD ASSY
48	PW02M	FLAT WASHER 5MM
49	PS20M	PHLP HD SCR M5-.8 X 15
50	PVM28	V-BELT M28



Accessories

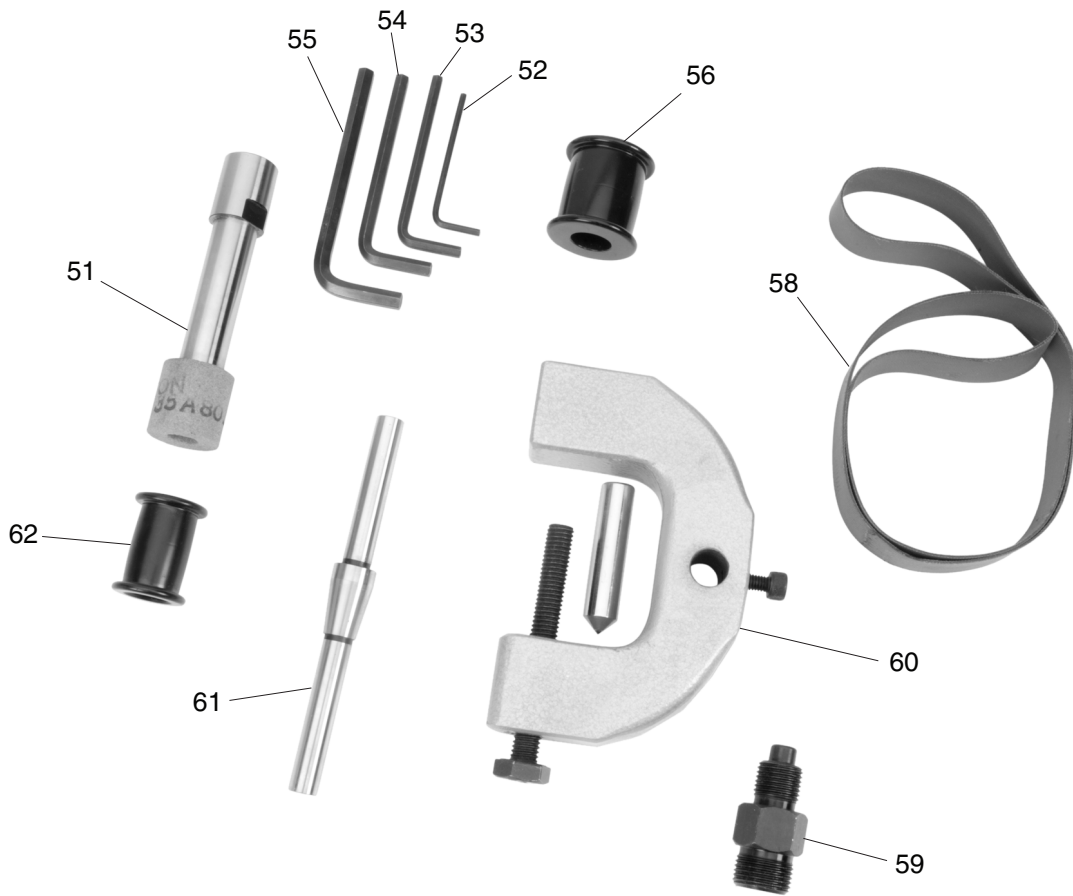

REF	PART #	DESCRIPTION
51	P0688051	INTERNAL GRINDING WHEEL 1"
52	PAW02.5M	HEX WRENCH 2.5MM
53	PAW04M	HEX WRENCH 4MM
54	PAW05M	HEX WRENCH 5MM
55	PAW06M	HEX WRENCH 6MM
56	P0688056	INT. SPINDLE PULLEY 16,500 RPM

REF	PART #	DESCRIPTION
58	P0688058	FLAT BELT 20 X 770MM
59	P0688059	PULLER TOOL
60	P0688060	DRESSER TOOL ASSEMBLY
61	P0688061	WHEEL BALANCING ARBOR
62	P0688062	INT. SPINDLE PULLEY 23,000 RPM



Label Placement

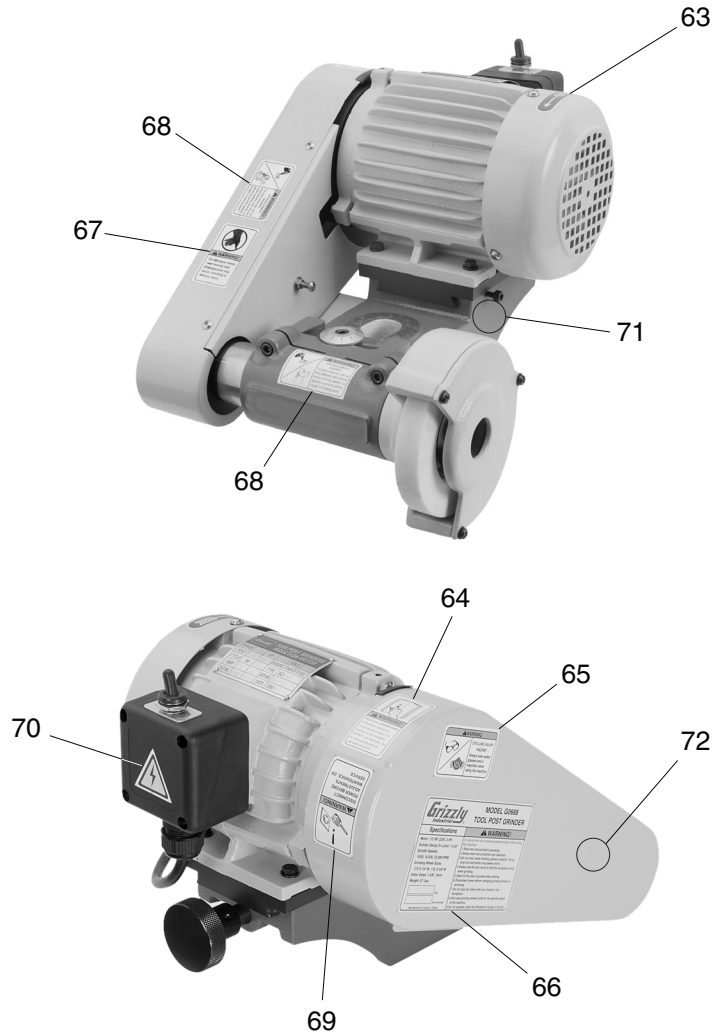

REF	PART #	DESCRIPTION
63	P0688063	ROTATION LABEL
64	PLABEL-12C	READ MANUAL LABEL
65	PLABEL-56C	EYE/LUNG HAZARD LABEL
66	P0688066	MACHINE ID LABEL
67	P0688067	BELT HAZARD LABEL

REF	PART #	DESCRIPTION
68	PLABEL-55C	ENTANGLEMENT HAZARD LABEL
69	PLABEL-63A	DISCONNECT LABEL
70	PLABEL-14B	ELECTRICITY LABEL
71	PPAINT-1	GRIZZLY GREEN TOUCH UP PAINT
72	PPAINT-11	GRIZZLY PUTTY TOUCH UP PAINT

⚠️ WARNING

Safety labels warn about machine hazards and ways to prevent injury. The owner of this machine **MUST** maintain the original location and readability of the labels on the machine. If any label is removed or becomes unreadable, **REPLACE** that label before using the machine again. Contact Grizzly at (800) 523-4777 or www.grizzly.com to order new labels.





WARRANTY CARD

Name _____

Street _____

City _____ State _____ Zip _____

Phone # _____ Email _____ Invoice # _____

Model # _____ Order # _____ Serial # _____

The following information is given on a voluntary basis. It will be used for marketing purposes to help us develop better products and services. **Of course, all information is strictly confidential.**

1. How did you learn about us?

- Advertisement
- Card Deck
- Friend
- Website
- Catalog
- Other:

2. Which of the following magazines do you subscribe to?

- | | | |
|---|--|---|
| <input type="checkbox"/> Cabinet Maker | <input type="checkbox"/> Popular Mechanics | <input type="checkbox"/> Today's Homeowner |
| <input type="checkbox"/> Family Handyman | <input type="checkbox"/> Popular Science | <input type="checkbox"/> Wood |
| <input type="checkbox"/> Hand Loader | <input type="checkbox"/> Popular Woodworking | <input type="checkbox"/> Wooden Boat |
| <input type="checkbox"/> Handy | <input type="checkbox"/> Practical Homeowner | <input type="checkbox"/> Woodshop News |
| <input type="checkbox"/> Home Shop Machinist | <input type="checkbox"/> Precision Shooter | <input type="checkbox"/> Woodsmith |
| <input type="checkbox"/> Journal of Light Cont. | <input type="checkbox"/> Projects in Metal | <input type="checkbox"/> Woodwork |
| <input type="checkbox"/> Live Steam | <input type="checkbox"/> RC Modeler | <input type="checkbox"/> Woodworker West |
| <input type="checkbox"/> Model Airplane News | <input type="checkbox"/> Rifle | <input type="checkbox"/> Woodworker's Journal |
| <input type="checkbox"/> Modeltec | <input type="checkbox"/> Shop Notes | <input type="checkbox"/> Other: |
| <input type="checkbox"/> Old House Journal | <input type="checkbox"/> Shotgun News | |

3. What is your annual household income?

- \$20,000-\$29,000
- \$30,000-\$39,000
- \$40,000-\$49,000
- \$50,000-\$59,000
- \$60,000-\$69,000
- \$70,000+

4. What is your age group?

- 20-29
- 30-39
- 40-49
- 50-59
- 60-69
- 70+

5. How long have you been a woodworker/metalworker?

- 0-2 Years
- 2-8 Years
- 8-20 Years
- 20+ Years

6. How many of your machines or tools are Grizzly?

- 0-2
- 3-5
- 6-9
- 10+

7. Do you think your machine represents a good value? Yes No

8. Would you recommend Grizzly Industrial to a friend? Yes No

9. Would you allow us to use your name as a reference for Grizzly customers in your area?

Note: We never use names more than 3 times. Yes No

10. Comments: _____

CUT ALONG DOTTED LINE

FOLD ALONG DOTTED LINE



Place Stamp Here



GRIZZLY INDUSTRIAL, INC.
P.O. BOX 2069
BELLINGHAM, WA 98227-2069



FOLD ALONG DOTTED LINE

Send a Grizzly Catalog to a friend:

Name _____
Street _____
City _____ State _____ Zip _____

TAPE ALONG EDGES--PLEASE DO NOT STAPLE

WARRANTY AND RETURNS

Grizzly Industrial, Inc. warrants every product it sells for a period of **1 year** to the original purchaser from the date of purchase. This warranty does not apply to defects due directly or indirectly to misuse, abuse, negligence, accidents, repairs or alterations or lack of maintenance. This is Grizzly's sole written warranty and any and all warranties that may be implied by law, including any merchantability or fitness, for any particular purpose, are hereby limited to the duration of this written warranty. We do not warrant or represent that the merchandise complies with the provisions of any law or acts unless the manufacturer so warrants. In no event shall Grizzly's liability under this warranty exceed the purchase price paid for the product and any legal actions brought against Grizzly shall be tried in the State of Washington, County of Whatcom.

We shall in no event be liable for death, injuries to persons or property or for incidental, contingent, special, or consequential damages arising from the use of our products.

To take advantage of this warranty, contact us by mail or phone and give us all the details. We will then issue you a "Return Number," which must be clearly posted on the outside as well as the inside of the carton. We will not accept any item back without this number. Proof of purchase must accompany the merchandise.

The manufacturers reserve the right to change specifications at any time because they constantly strive to achieve better quality equipment. We make every effort to ensure that our products meet high quality and durability standards and we hope you never need to use this warranty.

Please feel free to write or call us if you have any questions about the machine or the manual.

Thank you again for your business and continued support. We hope to serve you again soon.

grizzly.com[®]

TOOL WEBSITE

Buy Direct and Save with Grizzly[®] – Trusted, Proven and a Great Value!
~Since 1983~

*Visit Our Website Today For
Current Specials!*

**ORDER
24 HOURS A DAY!
1-800-523-4777**

