

# *Grizzly* *Industrial, Inc.*®

## MODEL G0701 19" ULTIMATE BANDSAW OWNER'S MANUAL *(For models manufactured since 11/24)*



COPYRIGHT © OCTOBER, 2009 BY GRIZZLY INDUSTRIAL, INC., REVISED NOVEMBER, 2024 (LW)  
**WARNING: NO PORTION OF THIS MANUAL MAY BE REPRODUCED IN ANY SHAPE  
OR FORM WITHOUT THE WRITTEN APPROVAL OF GRIZZLY INDUSTRIAL, INC.**  
#BLTS12076 PRINTED IN TAIWAN

V4.11.24

**\*\*\*Keep for Future Reference\*\*\***



## **WARNING!**

**This manual provides critical safety instructions on the proper setup, operation, maintenance, and service of this machine/tool. Save this document, refer to it often, and use it to instruct other operators.**

**Failure to read, understand and follow the instructions in this manual may result in fire or serious personal injury—including amputation, electrocution, or death.**

**The owner of this machine/tool is solely responsible for its safe use. This responsibility includes but is not limited to proper installation in a safe environment, personnel training and usage authorization, proper inspection and maintenance, manual availability and comprehension, application of safety devices, cutting/sanding/grinding tool integrity, and the usage of personal protective equipment.**

**The manufacturer will not be held liable for injury or property damage from negligence, improper training, machine modifications or misuse.**



## **WARNING!**

**Some dust created by power sanding, sawing, grinding, drilling, and other construction activities contains chemicals known to the State of California to cause cancer, birth defects or other reproductive harm. Some examples of these chemicals are:**

- **Lead from lead-based paints.**
- **Crystalline silica from bricks, cement and other masonry products.**
- **Arsenic and chromium from chemically-treated lumber.**

**Your risk from these exposures varies, depending on how often you do this type of work. To reduce your exposure to these chemicals: Work in a well ventilated area, and work with approved safety equipment, such as those dust masks that are specially designed to filter out microscopic particles.**

# Table of Contents

<b>INTRODUCTION.....</b>	<b>2</b>	<b>SECTION 5: ACCESSORIES .....</b>	<b>46</b>
Contact Info .....	2	<b>SECTION 6: MAINTENANCE.....</b>	<b>48</b>
Machine Description .....	2	Schedule .....	48
Manual Accuracy .....	2	Wheel Brushes .....	48
Identification.....	3	Cleaning & Protecting .....	48
Controls & Components.....	4	Lubrication .....	48
Machine Data Sheet .....	6	Redressing Rubber Tires .....	51
<b>SECTION 1: SAFETY .....</b>	<b>8</b>	<b>SECTION 7: SERVICE .....</b>	<b>52</b>
Safety Instructions for Machinery .....	8	Troubleshooting .....	52
Additional Safety for Bandsaws .....	10	Checking & Tensioning V-Belts.....	56
<b>SECTION 2: POWER SUPPLY .....</b>	<b>11</b>	Blade Lead.....	58
<b>SECTION 3: SETUP .....</b>	<b>13</b>	Adjusting Wheel & Blade Brushes.....	59
Needed for Setup.....	13	Adjusting Tension Lever.....	59
Unpacking .....	13	Adjusting Guide Post Travel .....	60
Inventory .....	14	Replacing Guide Post Motor.....	62
Cleanup.....	14	Replacing Brake Shoe .....	63
Site Considerations.....	15	Aligning Wheels .....	64
Moving & Placing Bandsaw .....	16	<b>SECTION 8: WIRING.....</b>	<b>67</b>
Anchoring to Floor .....	17	Wiring Safety Instructions .....	67
Assembly .....	17	Electrical Overview .....	68
Dust Collection.....	18	Junction Box, Motor & Magnetic Switch .....	69
Adjustment Overview .....	19	Control Panel & Guide Post Control .....	70
Initial Blade Tracking.....	19	Door Switch, Post Motor & Brake Switch ...	71
Adjusting Positive Stop .....	20	<b>SECTION 9: PARTS .....</b>	<b>72</b>
Test Run.....	22	Frame.....	72
Tensioning Blade .....	24	Wheels.....	75
Aligning Blade Support Bearings.....	25	Table .....	77
Adjusting Blade Guide Bearings .....	28	Guides.....	78
Aligning Table.....	29	Guide Post Elevation Assembly.....	80
Aligning Fence .....	30	Fence Assembly & Tools.....	81
Calibrating Miter Gauge.....	31	Labels & Cosmetics .....	82
Calibrating Fence Pointer .....	32	<b>WARRANTY &amp; RETURNS.....</b>	<b>85</b>
<b>SECTION 4: OPERATIONS.....</b>	<b>33</b>		
Operation Overview .....	33		
Workpiece Inspection.....	34		
Operating Foot Brake .....	35		
Table Tilt.....	35		
Guide Post.....	36		
Fine Tune Tracking .....	36		
Blade Selection.....	37		
Blade Selection Chart.....	40		
Blade Breakage .....	41		
Blade Care & Break-In.....	41		
Changing Blade .....	42		
Ripping.....	43		
Crosscutting .....	43		
Resawing .....	44		
Cutting Curves.....	45		
Stacked Cuts .....	45		

# INTRODUCTION

## Contact Info

We stand behind our machines! If you have questions or need help, contact us with the information below. Before contacting, make sure you get the **serial number** and **manufacture date** from the machine ID label. This will help us help you faster.

Grizzly Technical Support  
1815 W. Battlefield  
Springfield, MO 65807  
Phone: (570) 546-9663  
Email: techsupport@grizzly.com

We want your feedback on this manual. What did you like about it? Where could it be improved? Please take a few minutes to give us feedback.

Grizzly Documentation Manager  
P.O. Box 2069  
Bellingham, WA 98227-2069  
Email: manuals@grizzly.com

## Machine Description

The bandsaw is a versatile woodworking tool that is used to perform a wide variety of cuts in wood stock, such as rip cuts, cross cuts, bevel cuts, miter cuts, circular cuts, contour cuts, stacked pattern cuts, etc.

The saw blade is a continuous metal band wrapped around two rotating wheels, which performs the cut as it passes through the workpiece and table. Adjustable blade guide and support bearings keep the blade in position during this operation.

The Model G0701 also features a powered guide post for quick and accurate positioning of the upper guide and support bearings relative to the workpiece.

## Manual Accuracy

We are proud to provide a high-quality owner's manual with your new machine!

We made every effort to be exact with the instructions, specifications, drawings, and photographs in this manual. Sometimes we make mistakes, but our policy of continuous improvement also means that **sometimes the machine you receive is slightly different than shown in the manual.**

If you find this to be the case, and the difference between the manual and machine leaves you confused or unsure about something, check our website for an updated version. We post current manuals and manual updates for free on our website at [www.grizzly.com](http://www.grizzly.com).

Alternatively, you can call our Technical Support for help. Before calling, make sure you write down the **manufacture date** and **serial number** from the machine ID label (see below). This information is required for us to provide proper tech support, and it helps us determine if updated documentation is available for your machine.

		<b>MODEL GXXXX</b> <b>MACHINE NAME</b>	
<b>SPECIFICATIONS</b>		<b>WARNING!</b>	
Motor:		To reduce risk of serious injury when using this machine:	
Specification:		1. Read manual before operation.	
Specification:		2. Wear safety glasses and respirator.	
Specification:		3. Make sure blade is correctly adjusted/setup and	
Specification:		4. Make sure the motor has stopped and disconnect	
Weight:		5. DO NOT expose to rain or dampness.	
		6. DO NOT modify this machine in any way.	
		7.	
		8.	
		9.	
		10. Maintain machine carefully to prevent accidents.	
Manufactured for Grizzly in Taiwan			

Manufacture Date

Serial Number



# Identification

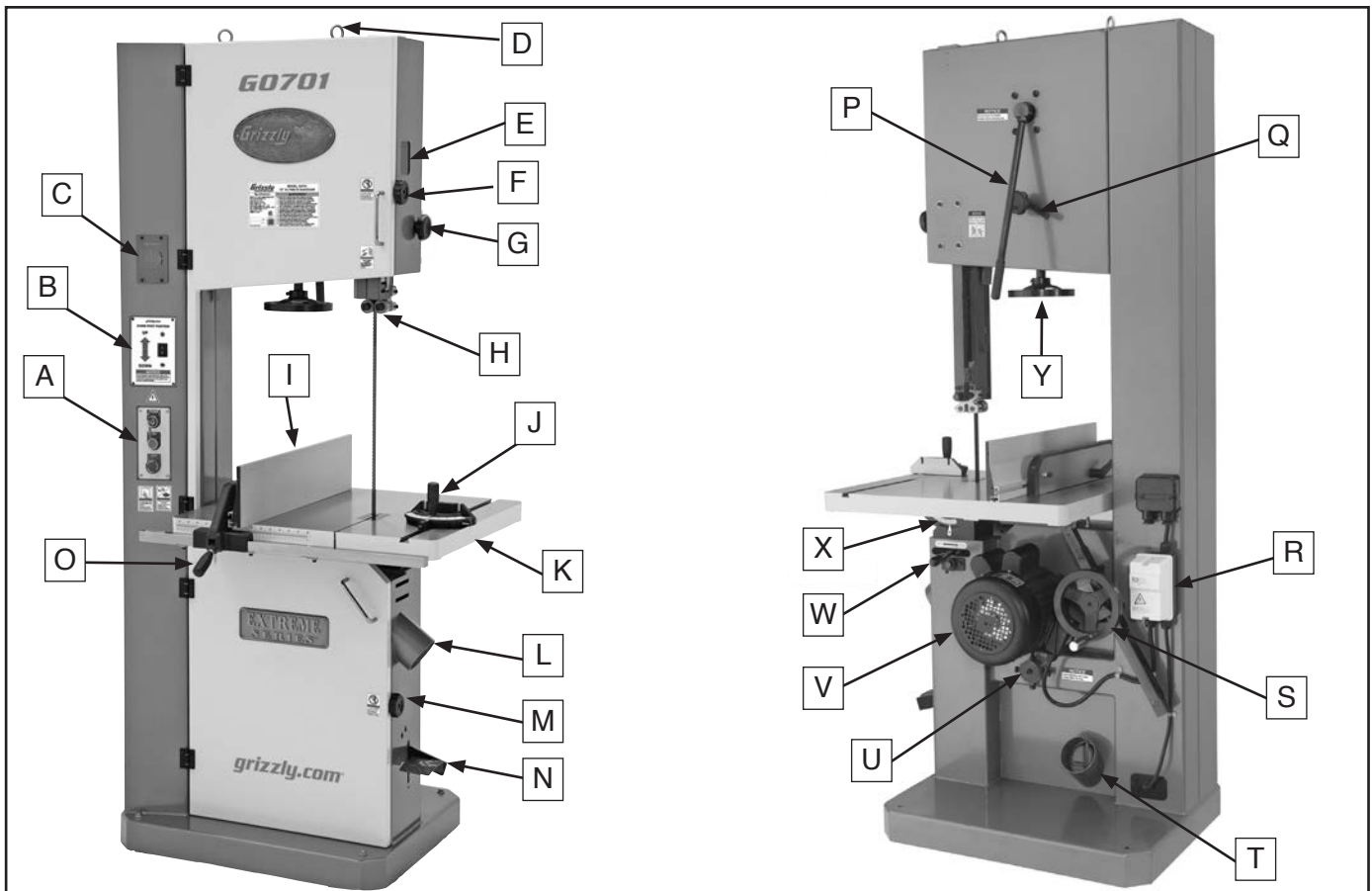

- |  |   |
|--|---|
| <p><b>A.</b> Control Panel</p> <p><b>B.</b> Guide Post Elevation Control</p> <p><b>C.</b> Blade Tension Scale</p> <p><b>D.</b> Lifting Eye Bolts</p> <p><b>E.</b> Blade Tracking Window</p> <p><b>F.</b> Upper Wheel Cover Lock Knob</p> <p><b>G.</b> Guide Post Lock Knob</p> <p><b>H.</b> Upper Blade Guide Assembly</p> <p><b>I.</b> Fence w/Resaw Attachment</p> <p><b>J.</b> Miter Gauge</p> <p><b>K.</b> Table</p> <p><b>L.</b> 4" Side Dust Port</p> <p><b>M.</b> Lower Wheel Cover Lock Knob</p> | <p><b>N.</b> Foot Brake</p> <p><b>O.</b> Fence Lock Lever</p> <p><b>P.</b> Blade Tension Quick Release Lever</p> <p><b>Q.</b> Blade Tracking Knob &amp; Lock Lever</p> <p><b>R.</b> Magnetic Switch</p> <p><b>S.</b> Table Tilt Handwheel</p> <p><b>T.</b> 4" Rear Dust Port</p> <p><b>U.</b> Lower Wheel Adjustment Hub</p> <p><b>V.</b> Main Motor</p> <p><b>W.</b> Table Tilt Lock Handle</p> <p><b>X.</b> Table Tilt Scale</p> <p><b>Y.</b> Blade Tension Handwheel</p> |
|--|---|

## CAUTION

**For Your Own Safety, Read Instruction Manual Before Operating Saw.**

- a) **Wear eye protection.**
- b) **Do not remove jammed cutoff pieces until blade has stopped.**
- c) **Maintain proper adjustment of blade tension, blade guides, and thrust bearings.**
- d) **Adjust upper guide to just clear workpiece.**
- e) **Hold workpiece firmly against table.**



# Controls & Components



Refer to the following figures and descriptions to become familiar with the basic controls and components of this machine. Understanding these items and how they work will help you understand the rest of the manual and minimize your risk of injury when operating this machine.

## Front Controls

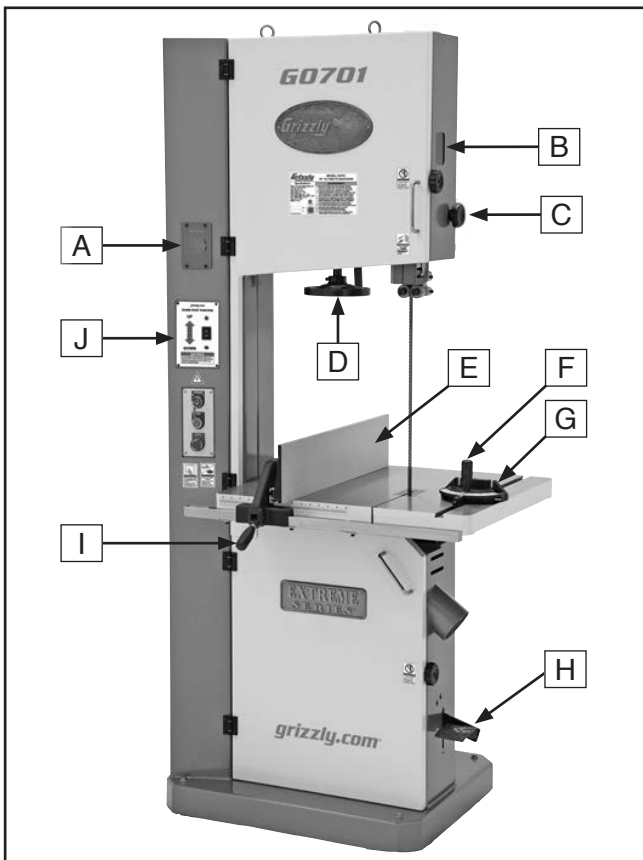

Figure 1. Front controls.

- A. **Blade Tension Scale:** Provides a way to gauge how much tension is applied to blade.
- B. **Blade Tracking Window:** Allows monitoring/adjustment of blade tracking without requiring wheel cover to be open.
- C. **Guide Post Lock Knob:** Locks guide post setting. Lock knob must be loosened before moving upper blade guides with guide post elevation control, or motor could burn out.
- D. **Blade Tension Handwheel:** Tensions blade in gradual increments.
- E. **Fence:** Used for ripping or resawing. Distance from blade determines width of cut. Can be used in vertical position (as shown in **Figure 1**) for normal workpieces, or in horizontal position for thin workpieces.
- F. **Miter Gauge Lock Knob:** Secures angle position of miter gauge.
- G. **Miter Gauge:** Typically used for cross cuts. Can be adjusted from 0°–60° left or right, and has stops at 45°L, 90°, and 45°R.
- H. **Foot Brake:** Cuts power to motor and brings the blade to a quick stop.
- I. **Fence Lock Handle:** Secures fence position.
- J. **Guide Post Elevation Control:** Controls the powered guide post motor, which is used to raise or lower the guide post and upper blade guides to the desired height above the workpiece.



## Rear Controls

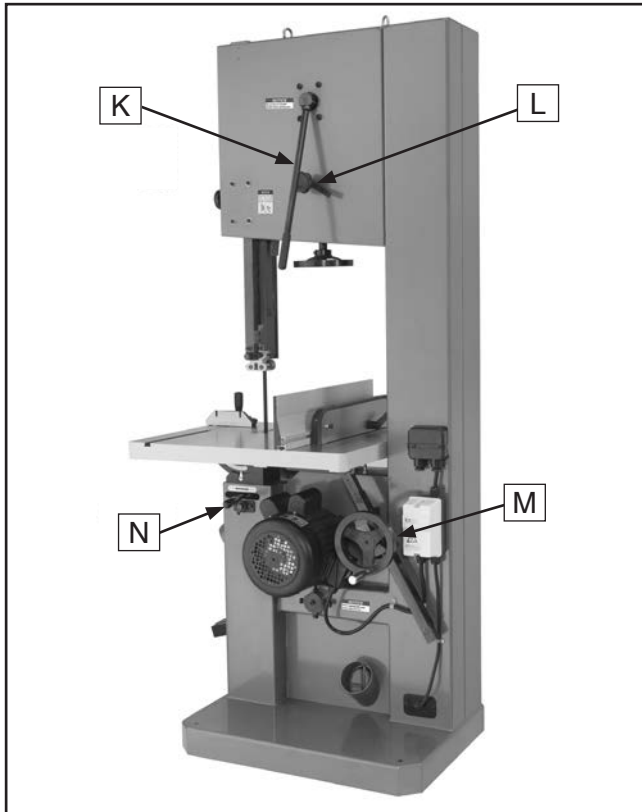

Figure 2. Rear controls.

- K. Blade Tension Quick Release Lever:** Adjusts blade tension for quick blade changes.
- L. Blade Tracking Knob and Lock Lever:** Moves and locks blade tracking.
- M. Table Tilt Handwheel:** Tilts the table up to 5° to the left or 45° to the right.
- N. Table Tilt Lock Handle:** Locks or unlocks the table at the current angle.

## Control Panel

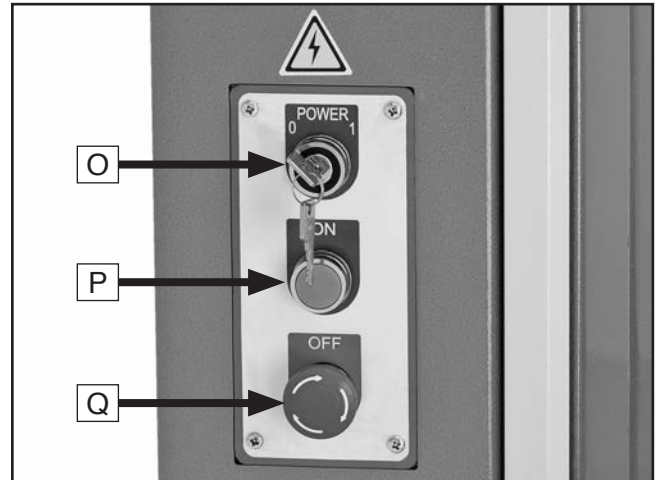

Figure 3. Control panel.

- O. Master Power Key Switch:** Turns incoming power **ON** and **OFF**. Requires key.
- P. ON Button:** Turns motor **ON** when pressed.
- Q. Emergency Stop/Reset Button:** Turns motor **OFF** when pressed. Motor will not start until switch is reset. Twist clockwise to reset.





# MACHINE DATA SHEET

Customer Service #: (570) 546-9663 · To Order Call: (800) 523-4777 · Fax #: (800) 438-5901

## MODEL G0701 19" ULTIMATE BANDSAW

### Product Dimensions:

Weight..... 717 lbs.  
 Width (side-to-side) x Depth (front-to-back) x Height..... 36-5/8 x 33 x 86-1/2 in.  
 Footprint (Length x Width)..... 31 x 23-1/2 in.

### Shipping Dimensions:

Type..... Wood Crate  
 Content..... Machine  
 Weight..... 810 lbs.  
 Length x Width x Height..... 36 x 28 x 87 in.

### Electrical:

Power Requirement..... 230V, Single-Phase, 60 Hz  
 Full-Load Current Rating..... 27A  
 Minimum Circuit Size..... 30A  
 Connection Type..... Permanent (Hardwire to Shutoff Switch)  
 Switch Type..... Control Panel w/Magnetic Switch Protection & Lockout Key

### Motors:

#### Main

Horsepower..... 5 HP  
 Phase..... Single-Phase  
 Amps..... 22A  
 Speed..... 1720 RPM  
 Type..... TEFC Capacitor-Start Induction  
 Power Transfer ..... Belt Drive  
 Bearings..... Shielded & Permanently Lubricated  
 Centrifugal Switch/Contacts Type..... External

#### Guide Post Elevation

Horsepower..... 40W  
 Amps..... 4A  
 Speed..... 4300 RPM  
 Type..... Universal  
 Power Transfer ..... Gear Drive  
 Bearings..... Sealed & Permanently Lubricated

### Main Specifications:

#### Main Specifications

Bandsaw Size..... 19 in.  
 Max Cutting Width (Left of Blade)..... 18-3/8 in.  
 Max Cutting Width (Left of Blade) w/Fence..... 17-1/4 in.  
 Max Cutting Height (Resaw Height)..... 19-1/2 in.  
 Blade Speeds..... 4975 FPM



**Blade Information**

Standard Blade Length.....	166 in.
Blade Length Range.....	166 – 168 in.
Blade Width Range.....	3/8 – 1-3/8 in.
Type of Blade Guides.....	Double Ball Bearing
Guide Post Adjustment Type.....	Motorized
Has Quick-Release.....	Yes

**Table Information**

Table Length.....	24 in.
Table Width.....	28 in.
Table Thickness.....	1-7/8 in.
Table Tilt.....	Left 5, Right 45 deg.
Table Tilt Adjustment Type.....	Rack & Pinion
Floor-to-Table Height.....	35-1/4 in.
Fence Locking Position.....	Front
Fence is Adjustable for Blade Lead.....	Yes
Resaw Fence Attachment Included.....	Yes
Miter Gauge Included.....	Yes

**Construction Materials**

Table.....	Precision-Ground Cast Iron
Trunnion.....	Cast Iron
Fence.....	Deluxe Extruded Aluminum & Cast Iron
Base/Stand.....	Pre-Formed Steel
Frame/Body.....	Pre-Formed Steel
Wheels.....	Computer-Balanced Cast Iron
Tire.....	Rubber
Wheel Cover .....	Pre-Formed Steel
Paint Type/Finish.....	Powder Coated

**Other Related Information**

Wheel Diameter.....	19 in.
Wheel Width.....	1-13/16 in.
Number of Dust Ports.....	2
Dust Port Size.....	4 in.
Compatible Mobile Base.....	D2058A

**Other Specifications:**

Country of Origin .....	Taiwan
Warranty .....	1 Year
Approximate Assembly & Setup Time .....	1 Hour
Serial Number Location .....	Machine ID Label
ISO 9001 Factory .....	Yes
Certified by a Nationally Recognized Testing Laboratory (NRTL) .....	Yes



# SECTION 1: SAFETY

## For Your Own Safety, Read Instruction Manual Before Operating This Machine

The purpose of safety symbols is to attract your attention to possible hazardous conditions. This manual uses a series of symbols and signal words intended to convey the level of importance of the safety messages. The progression of symbols is described below. Remember that safety messages by themselves do not eliminate danger and are not a substitute for proper accident prevention measures. Always use common sense and good judgment.



Indicates an imminently hazardous situation which, if not avoided, **WILL** result in death or serious injury.



Indicates a potentially hazardous situation which, if not avoided, **COULD** result in death or serious injury.



Indicates a potentially hazardous situation which, if not avoided, **MAY** result in minor or moderate injury. It may also be used to alert against unsafe practices.

**NOTICE**

Alerts the user to useful information about proper operation of the machine to avoid machine damage.

## Safety Instructions for Machinery



**OWNER'S MANUAL.** Read and understand this owner's manual **BEFORE** using machine.

**TRAINED OPERATORS ONLY.** Untrained operators have a higher risk of being hurt or killed. Only allow trained/supervised people to use this machine. When machine is not being used, disconnect power, remove switch keys, or lock-out machine to prevent unauthorized use—especially around children. Make your workshop kid proof!

**DANGEROUS ENVIRONMENTS.** Do not use machinery in areas that are wet, cluttered, or have poor lighting. Operating machinery in these areas greatly increases the risk of accidents and injury.

**MENTAL ALERTNESS REQUIRED.** Full mental alertness is required for safe operation of machinery. Never operate under the influence of drugs or alcohol, when tired, or when distracted.

**ELECTRICAL EQUIPMENT INJURY RISKS.**

You can be shocked, burned, or killed by touching live electrical components or improperly grounded machinery. To reduce this risk, only allow qualified service personnel to do electrical installation or repair work, and always disconnect power before accessing or exposing electrical equipment.

**DISCONNECT POWER FIRST.** Always disconnect machine from power supply **BEFORE** making adjustments, changing tooling, or servicing machine. This prevents an injury risk from unintended startup or contact with live electrical components.

**EYE PROTECTION.** Always wear ANSI-approved safety glasses or a face shield when operating or observing machinery to reduce the risk of eye injury or blindness from flying particles. Everyday eyeglasses are **NOT** approved safety glasses.



# WARNING

**WEARING PROPER APPAREL.** Do not wear loose clothing, gloves, neckties, or jewelry that can become entangled in moving parts. Always tie back or cover long hair. Wear non-slip footwear to reduce risk of slipping and losing control or accidentally contacting cutting tool or moving parts.

**HAZARDOUS DUST.** Dust created by machinery operations may cause cancer, birth defects, or long-term respiratory damage. Be aware of dust hazards associated with each workpiece material. Always wear a NIOSH-approved respirator to reduce your risk.

**HEARING PROTECTION.** Always wear hearing protection when operating or observing loud machinery. Extended exposure to this noise without hearing protection can cause permanent hearing loss.

**REMOVE ADJUSTING TOOLS.** Tools left on machinery can become dangerous projectiles upon startup. Never leave chuck keys, wrenches, or any other tools on machine. Always verify removal before starting!

**USE CORRECT TOOL FOR THE JOB.** Only use this tool for its intended purpose—do not force it or an attachment to do a job for which it was not designed. Never make unapproved modifications—modifying tool or using it differently than intended may result in malfunction or mechanical failure that can lead to personal injury or death!

**AWKWARD POSITIONS.** Keep proper footing and balance at all times when operating machine. Do not overreach! Avoid awkward hand positions that make workpiece control difficult or increase the risk of accidental injury.

**CHILDREN & BYSTANDERS.** Keep children and bystanders at a safe distance from the work area. Stop using machine if they become a distraction.

**GUARDS & COVERS.** Guards and covers reduce accidental contact with moving parts or flying debris. Make sure they are properly installed, undamaged, and working correctly BEFORE operating machine.

**FORCING MACHINERY.** Do not force machine. It will do the job safer and better at the rate for which it was designed.

**NEVER STAND ON MACHINE.** Serious injury may occur if machine is tipped or if the cutting tool is unintentionally contacted.

**STABLE MACHINE.** Unexpected movement during operation greatly increases risk of injury or loss of control. Before starting, verify machine is stable and mobile base (if used) is locked.

**USE RECOMMENDED ACCESSORIES.** Consult this owner's manual or the manufacturer for recommended accessories. Using improper accessories will increase the risk of serious injury.

**UNATTENDED OPERATION.** To reduce the risk of accidental injury, turn machine **OFF** and ensure all moving parts completely stop before walking away. Never leave machine running while unattended.

**MAINTAIN WITH CARE.** Follow all maintenance instructions and lubrication schedules to keep machine in good working condition. A machine that is improperly maintained could malfunction, leading to serious personal injury or death.

**DAMAGED PARTS.** Regularly inspect machine for damaged, loose, or mis-adjusted parts—or any condition that could affect safe operation. Immediately repair/replace BEFORE operating machine. For your own safety, DO NOT operate machine with damaged parts!

**MAINTAIN POWER CORDS.** When disconnecting cord-connected machines from power, grab and pull the plug—NOT the cord. Pulling the cord may damage the wires inside. Do not handle cord/plug with wet hands. Avoid cord damage by keeping it away from heated surfaces, high traffic areas, harsh chemicals, and wet/damp locations.

**EXPERIENCING DIFFICULTIES.** If at any time you experience difficulties performing the intended operation, stop using the machine! Contact our Technical Support at (570) 546-9663.



# Additional Safety for Bandsaws

## WARNING

**Serious cuts, amputation, or death can occur from contact with the moving saw blade during operation or if blade breakage occurs. To reduce this risk, anyone operating this machine MUST completely heed the hazards and warnings below.**

**HAND PLACEMENT.** Placing hands or fingers in line with blade during operation may result in serious injury if hands slip or workpiece moves unexpectedly. Do not position fingers or hands in line with blade, and never reach under table while blade is moving.

**SMALL/NARROW WORKPIECES.** If hands slip during a cut while holding small workpieces with fingers, serious personal injury could occur. Always support/feed small or narrow workpieces with push sticks, push blocks, jig, vise, or some type of clamping fixture.

**BLADE SPEED.** Cutting workpiece before blade is at full speed could cause blade to grab workpiece and pull hands into blade. Allow blade to reach full speed before starting cut. DO NOT start machine with workpiece contacting blade.

**FEED RATE.** To avoid risk of workpiece slipping and causing operator injury, always feed stock evenly and smoothly.

**BLADE CONDITION.** Dull blades require more effort to perform cut, increasing risk of accidents. Do not operate with dirty, dull, cracked or badly worn blades. Inspect blades for cracks and missing teeth before each use. Always maintain proper blade tension and tracking while operating.

**CLEARING JAMS AND CUTOFFS.** Always stop bandsaw and disconnect power before clearing scrap pieces that get stuck between blade and table insert. Use brush or push stick, not hands, to clean chips/cutoff scraps from table.

**BLADE CONTROL.** To avoid risk of injury due to blade contact, always allow blade to stop on its own. DO NOT try to stop or slow blade with your hand or the workpiece.

**GUARDS/COVERS.** Blade guards and covers protect operator from the moving bandsaw blade. The wheel covers protect operator from getting entangled with rotating wheels or other moving parts. ONLY operate this bandsaw with blade guard in proper position and wheel covers completely closed.

**BLADE REPLACEMENT.** To avoid mishaps that could result in operator injury, make sure blade teeth face down toward table and blade is properly tensioned and tracked before operating.

**UPPER BLADE GUIDE SUPPORT.** To reduce exposure of operator to blade and provide maximum blade support while cutting, keep upper blade guides adjusted to just clear workpiece.

**CUTTING TECHNIQUES.** To avoid blade getting pulled off wheels or accidentally breaking and striking operator, always turn bandsaw **OFF** and wait for blade to come to a complete stop before backing workpiece out of blade. DO NOT back workpiece away from blade while bandsaw is running. DO NOT force or twist blade while cutting, especially when sawing small curves. This could result in blade damage or breakage.

**WORKPIECE SUPPORT.** To maintain maximum control and reduce risk of blade contact/breakage, always ensure adequate support of long/large workpieces. Always keep workpiece flat and firm against table/fence when cutting to avoid loss of control. If necessary, use a jig or other workholding device.

**WORKPIECE MATERIAL.** This machine is intended for cutting natural and man-made wood products, and laminate covered wood products. This machine is NOT designed to cut metal, glass, stone, tile, etc.



# SECTION 2: POWER SUPPLY

## Availability

Before installing the machine, consider the availability and proximity of the required power supply circuit. If an existing circuit does not meet the requirements for this machine, a new circuit must be installed. To minimize the risk of electrocution, fire, or equipment damage, installation work and electrical wiring must be done by an electrician or qualified service personnel in accordance with all applicable codes and standards.

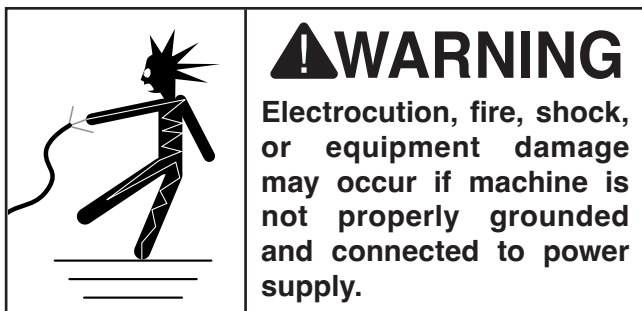

## Full-Load Current Rating

The full-load current rating is the amperage a machine draws at 100% of the rated output power. On machines with multiple motors, this is the amperage drawn by the largest motor or sum of all motors and electrical devices that might operate at one time during normal operations.

### Full-Load Current Rating at 230V ..... 22 Amps

The full-load current is not the maximum amount of amps that the machine will draw. If the machine is overloaded, it will draw additional amps beyond the full-load rating.

If the machine is overloaded for a sufficient length of time, damage, overheating, or fire may result—especially if connected to an undersized circuit. To reduce the risk of these hazards, avoid overloading the machine during operation and make sure it is connected to a power supply circuit that meets the specified circuit requirements.

## Circuit Information

A power supply circuit includes all electrical equipment between the breaker box or fuse panel in the building and the machine. The power supply circuit used for this machine must be sized to safely handle the full-load current drawn from the machine for an extended period of time. (If this machine is connected to a circuit protected by fuses, use a time delay fuse marked D.)

**⚠ CAUTION**  
For your own safety and protection of property, consult an electrician if you are unsure about wiring practices or electrical codes in your area.

*Note: Circuit requirements in this manual apply to a dedicated circuit—where only one machine will be running on the circuit at a time. If machine will be connected to a shared circuit where multiple machines may be running at the same time, consult an electrician or qualified service personnel to ensure circuit is properly sized for safe operation.*

## Circuit Requirements for 230V

This machine is prewired to operate on a power supply circuit that has a verified ground and meets the following requirements:

Nominal Voltage ..... 220V, 230V, 240V  
Cycle ..... 60 Hz  
Phase ..... Single-Phase  
Power Supply Circuit ..... 30 Amps  
Plug/Receptacle ..... NEMA L6-30  
Cord ..... "S"-Type, 3-Wire, 12 AWG, 300 VAC



## Grounding Instructions

This machine **MUST** be grounded. In the event of certain malfunctions or breakdowns, grounding reduces the risk of electric shock by providing a path of least resistance for electric current.

The power cord and plug specified under “Circuit Requirements for 220V” on the previous page has an equipment-grounding wire and a grounding prong. The plug must only be inserted into a matching receptacle (outlet) that is properly installed and grounded in accordance with all local codes and ordinances (see figure below).

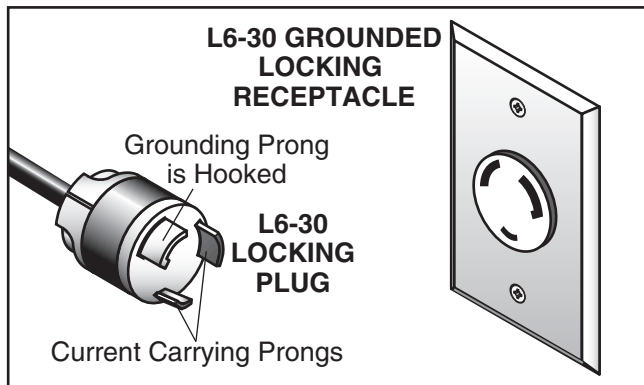
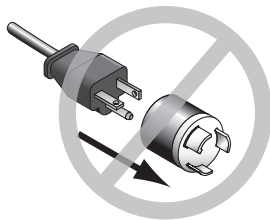

**Figure 4.** Typical L6-30 plug and receptacle.

## **⚠️ WARNING**

**Serious injury could occur if you connect machine to power before completing setup process. DO NOT connect to power until instructed later in this manual.**

## **⚠️ CAUTION**



**No adapter should be used with plug. If plug does not fit available receptacle, or if machine must be reconnected for use on a different type of circuit, reconnection must be performed by an electrician or qualified service personnel, and it must comply with all local codes and ordinances.**

## **⚠️ WARNING**

**Serious injury could occur if you connect machine to power before completing setup process. DO NOT connect to power until instructed later in this manual.**

Improper connection of the equipment-grounding wire can result in a risk of electric shock. The wire with green insulation (with or without yellow stripes) is the equipment-grounding wire. If repair or replacement of the power cord or plug is necessary, do not connect the equipment-grounding wire to a live (current carrying) terminal.

Check with a qualified electrician or service personnel if you do not understand these grounding requirements, or if you are in doubt about whether the tool is properly grounded. If you ever notice that a cord or plug is damaged or worn, disconnect it from power, and immediately replace it with a new one.

## Extension Cords

We do not recommend using an extension cord with this machine. If you must use an extension cord, only use it if absolutely necessary and only on a temporary basis.

Extension cords cause voltage drop, which can damage electrical components and shorten motor life. Voltage drop increases as the extension cord size gets longer and the gauge size gets smaller (higher gauge numbers indicate smaller sizes).

Any extension cord used with this machine must be in good condition and contain a ground wire and matching plug/receptacle. Additionally, it must meet the following size requirements:

**Minimum Gauge Size ..... 10 AWG**  
**Maximum Length (Shorter is Better)..... 50 ft.**



# SECTION 3: SETUP

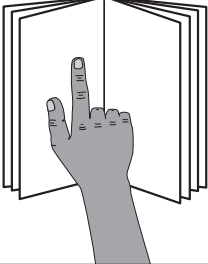

**!WARNING**  
 This machine presents serious injury hazards to untrained users. Read through this entire manual to become familiar with the controls and operations before starting the machine!



**!WARNING**  
 Wear safety glasses during the entire setup process!

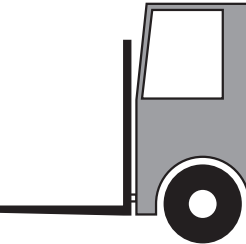

**!WARNING**  
 The Model G0701 is a heavy machine. Serious personal injury may occur if safe moving methods are not used. To be safe, get assistance and use power equipment to move the shipping crate and remove the machine from the crate.

**NOTICE**

If you are not experienced with this type of machine, **WE STRONGLY RECOMMEND** that you seek additional training outside of this manual. Read books/magazines or get formal training before beginning any projects. Regardless of the content in this section, Grizzly Industrial will not be held liable for accidents caused by lack of training.

## Needed for Setup

The following items are needed, but not included, for the setup/assembly of this machine.

Description	Qty
• Hex Wrench 5mm.....	1
• Hex Wrench 6mm.....	1
• Open-End Wrench 17mm.....	1
• Open-End Wrench or Socket 19mm .....	1
• Phillips Head Screwdriver #2 .....	1
• Machinist's Square .....	1
• 3' Straightedge .....	1
• Finely Incremented Ruler .....	1
• Safety Glasses (for each person).....	1 Pair
• Solvent/Cleaner ( <b>Page 47</b> ).....	1
• Shop Rags.....	As Needed
• Lifting Straps (Rated for at least 1000 lbs.)	2
• Lifting Equipment (Rated for at least 1000 lbs.).....	1

## Unpacking

This machine was carefully packaged for safe transport. When unpacking, separate all enclosed items from packaging materials and inspect them for shipping damage. ***If items are damaged, please call us immediately at (570) 546-9663.***

**IMPORTANT:** Save all packaging materials until you are completely satisfied with the machine and have resolved any issues between Grizzly or the shipping agent. ***You MUST have the original packaging to file a freight claim. It is also extremely helpful if you need to return your machine later.***



# Inventory

The following is a list of items shipped with your machine. Before beginning setup, lay these items out and inventory them.

If any non-proprietary parts are missing (e.g. a nut or a washer), we will gladly replace them; or for the sake of expediency, replacements can be obtained at your local hardware store.

## NOTICE

**If you cannot find an item on this list, carefully check around/inside the machine and packaging materials. Often, these items get lost in packaging materials while unpacking or they are pre-installed at the factory.**

Inventory (Figure 5)	Qty
A. Bandsaw (Not Shown).....	1
B. Standard Fence Assembly .....	1
C. Resaw Fence .....	1
D. Miter Gauge Assembly.....	1
E. Open-Ends Wrench 10/13mm .....	1
F. Open-Ends Wrench 17/19mm .....	1
G. Lifting Eye Bolts M12-1.75 x 20 .....	2
H. Resaw Fence Plate .....	1
I. Flat Washer 8mm (Resaw Fence).....	1
J. Resaw Fence Lock Lever M8-1.25 x 45.....	1
K. Hex Wrench 6mm.....	1
L. Hex Wrench 5mm.....	1

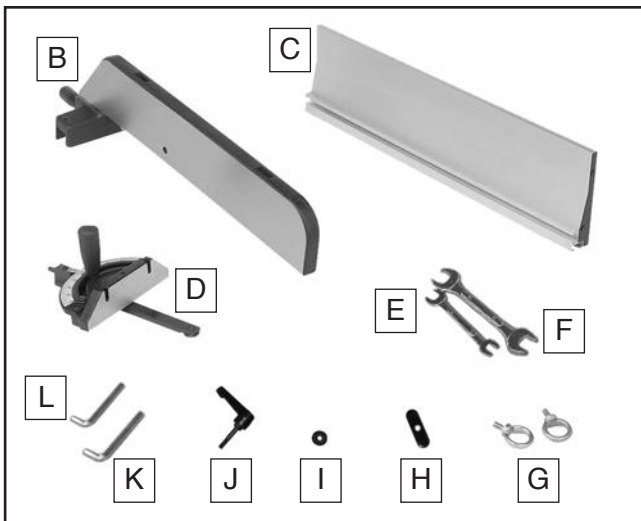

Figure 5. G0701 inventory.

# Cleanup

The unpainted surfaces of your machine are coated with a heavy-duty rust preventative that prevents corrosion during shipment and storage. This rust preventative works extremely well, but it will take a little time to clean.

Be patient and do a thorough job cleaning your machine. The time you spend doing this now will give you a better appreciation for the proper care of your machine's unpainted surfaces.

There are many ways to remove this rust preventative, but the following steps work well in a wide variety of situations. Always follow the manufacturer's instructions with any cleaning product you use and make sure you work in a well-ventilated area to minimize exposure to toxic fumes.

### Before cleaning, gather the following:

- Disposable rags
- Cleaner/degreaser (WD-40 works well)
- Safety glasses & disposable gloves
- Plastic paint scraper (optional)

### Basic steps for removing rust preventative:

1. Put on safety glasses.
2. Coat the rust preventative with a liberal amount of cleaner/degreaser, then let it soak for 5–10 minutes.
3. Wipe off the surfaces. If your cleaner/degreaser is effective, the rust preventative will wipe off easily. If you have a plastic paint scraper, scrape off as much as you can first, then wipe off the rest with the rag.
4. Repeat **Steps 2–3** as necessary until clean, then coat all unpainted surfaces with a quality metal protectant to prevent rust.

## NOTICE

**Avoid harsh solvents like acetone or brake parts cleaner that may damage painted surfaces. Always test on a small, inconspicuous location first.**



# Site Considerations

## Weight Load

Refer to the **Machine Data Sheet** for the weight of your machine. Make sure that the surface upon which the machine is placed will bear the weight of the machine, additional equipment that may be installed on the machine, and the heaviest workpiece that will be used. Additionally, consider the weight of the operator and any dynamic loading that may occur when operating the machine.

## Space Allocation

Consider the largest size of workpiece that will be processed through this machine and provide enough space around the machine for adequate operator material handling or the installation of auxiliary equipment. With permanent installations, leave enough space around the machine to open or remove doors/covers as required by the maintenance and service described in this manual. **See below for required space allocation.**

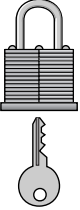
	<p><b>⚠ CAUTION</b> Children or untrained people may be seriously injured by this machine. Only install in an access restricted location.</p>
---	---

## Physical Environment

The physical environment where the machine is operated is important for safe operation and longevity of machine components. For best results, operate this machine in a dry environment that is free from excessive moisture, hazardous chemicals, airborne abrasives, or extreme conditions. Extreme conditions for this type of machinery are generally those where the ambient temperature range exceeds 41°–104°F; the relative humidity range exceeds 20%–95% (non-condensing); or the environment is subject to vibration, shocks, or bumps.

## Electrical Installation

Place this machine near an existing power source. Make sure all power cords are protected from traffic, material handling, moisture, chemicals, or other hazards. Make sure to leave enough space around machine to disconnect power supply or apply a lockout/tagout device, if required.

## Lighting

Lighting around the machine must be adequate enough that operations can be performed safely. Shadows, glare, or strobe effects that may distract or impede the operator must be eliminated.

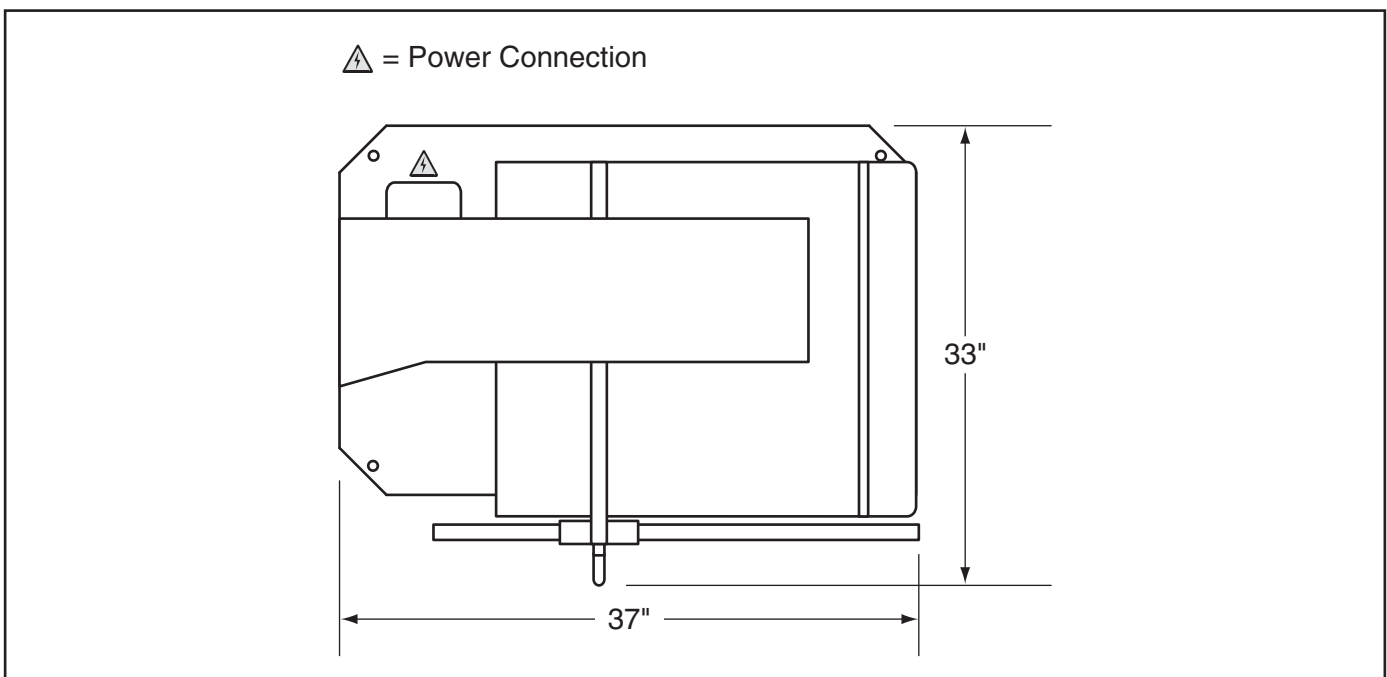

**Figure 6.** Minimum working clearances.



# Moving & Placing Bandsaw

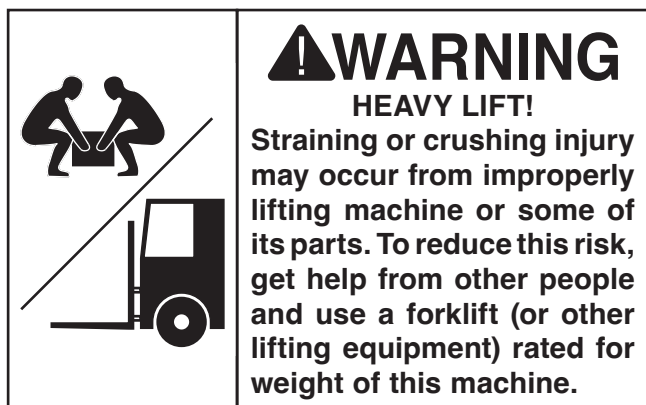

Take special care when lifting and moving the Model G0701. Use only one of the following methods to place your bandsaw in its operating location.

## Using Lifting Eye Bolts

1. With the help of another person to steady the load, use the forklift to move the shipping pallet and bandsaw to its operating location.
2. Remove the shipping crate from the pallet.
3. Install the lifting eye bolts, as illustrated in **Figure 7**, making sure they are threaded all the way in.

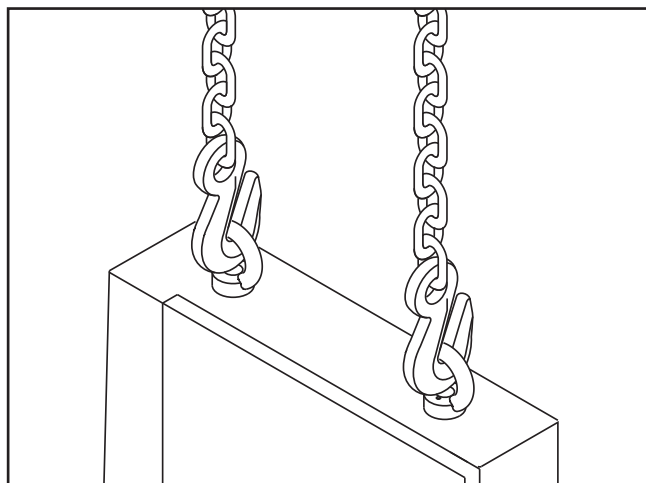

**Figure 7.** Lifting eye bolts installed.

4. Unbolt the bandsaw from the shipping pallet.
5. Attach the safety lifting hooks and chains/straps (rated for at least 1000 lbs.) to the eye bolts and forklift/hoist, then slowly lift the bandsaw.
6. Carefully remove the shipping pallet and place the bandsaw on the floor.
7. Mount the machine to the floor with one of the options outlined in the next subsection.

## Using Wood Blocks

1. With the help of another person to steady the load, use the forklift to move the shipping pallet and bandsaw to its operating location.
2. Remove the shipping crate from the pallet.
3. Unbolt the bandsaw from the shipping pallet.
4. Carefully position the forks of the forklift under the bandsaw head, as shown in **Figure 8**, then place a 1x4 wood block between the head and the right fork and a 2x4 wood block between the head and the left fork.

**Note:** If you are concerned about your forklift forks hitting the tension handwheel, remove it for this step, then re-install it afterward.

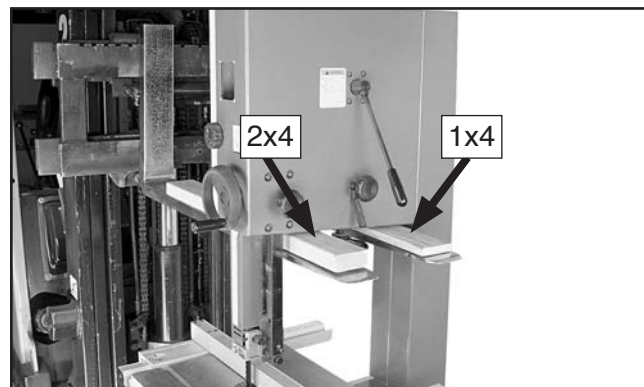

**Figure 8.** Using wood blocks to lift the bandsaw.

5. With the help of another person to steady the load, carefully lift the bandsaw, remove the shipping pallet, then place the machine on the floor.
6. Mount the machine to the floor with one of the options outlined in the next subsection.



# Anchoring to Floor

**Number of Mounting Holes** ..... 4  
**Diameter of Mounting Hardware**..... 1/2"

Anchoring machinery to the floor prevents tipping or shifting and reduces vibration that may occur during operation, resulting in a machine that runs slightly more quietly and feels more solid.

If the machine will be installed in a commercial or workplace setting, or if it is permanently connected (hardwired) to the power supply, local codes may require that it be anchored to the floor.

If not required by any local codes, fastening the machine to the floor is an optional step. If you choose not to do this with your machine, we recommend placing it on machine mounts, as these provide an easy method for leveling and they have vibration-absorbing pads.

## Anchoring to Concrete Floors

Lag shield anchors with lag screws (see below) are a popular way to anchor machinery to a concrete floor, because the anchors sit flush with the floor surface, making it easy to unbolt and move the machine later, if needed. However, anytime local codes apply, you **MUST** follow the anchoring methodology specified by the code.

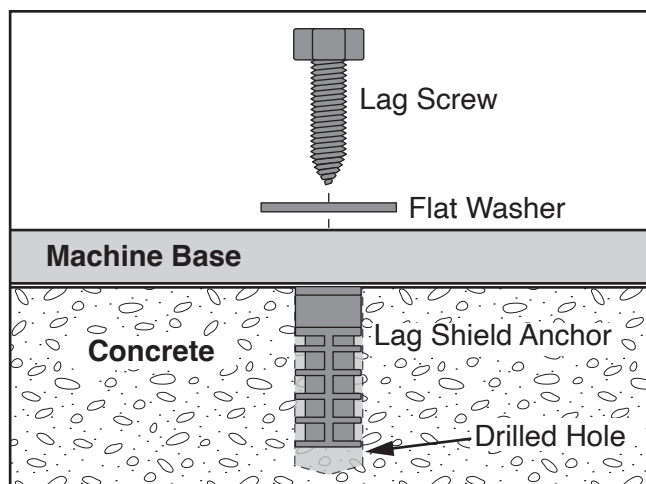

**Figure 9.** Popular method for anchoring machinery to a concrete floor.

# Assembly

The machine must be fully assembled before it can be operated. Before beginning the assembly process, refer to **Needed for Setup** and gather all listed items. To ensure the assembly process goes smoothly, first clean any parts that are covered or coated in heavy-duty rust preventative (if applicable).

## To assemble bandsaw:

1. Remove the three cap screws, lock washers, and flat washers shown in **Figure 10**.

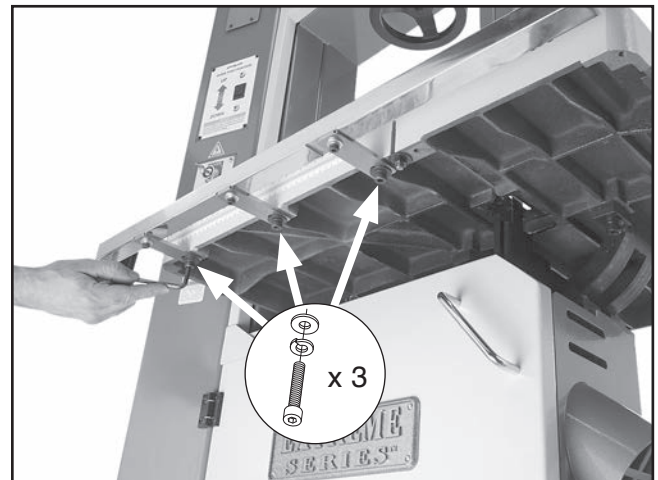
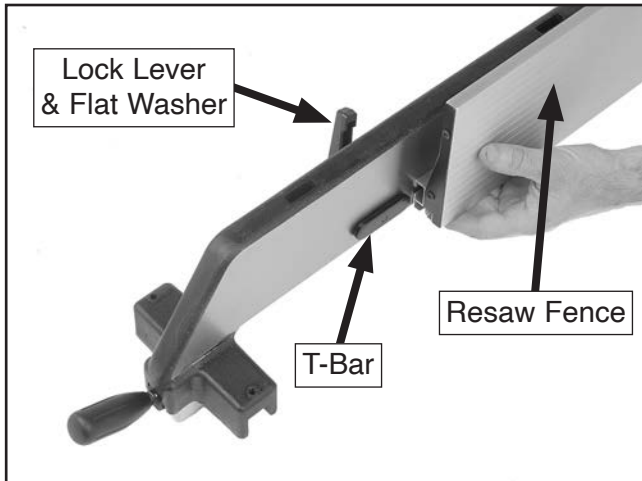

**Figure 10.** Fence rail in the correct position.

2. Flip the fence rail over and re-attach it with the fasteners removed in **Step 1**.



- Slide the 8mm flat washer onto the resaw fence lock lever, then insert the assembly through the standard fence (see **Figure 11**).
- Thread the T-bar onto the lock lever a couple of turns, align the resaw fence slot and the T-bar, then slide the resaw fence fully onto the standard fence, as shown in **Figure 11**.



**Figure 11.** Resaw fence components.

- Tighten the lock lever to secure the resaw fence in position.
- Pull the fence handle up, then place the fence on the fence rail, as shown in **Figure 12**.



**Figure 12.** Fence assembly mounted on the fence rail.

- To secure the fence in place, push down on the fence handle.

## Dust Collection

### ⚠ CAUTION

**DO NOT** operate the Model G0701 without an adequate dust collection system. This saw creates substantial amounts of wood dust while operating. Failure to use a dust collection system can result in short and long-term respiratory illness.

#### Recommended CFM

##### At Each Dust Port: 400 CFM

*Do not confuse this CFM recommendation with the rating of the dust collector. To determine the CFM at the dust port, you must consider these variables: (1) CFM rating of the dust collector, (2) hose type and length between the dust collector and the machine, (3) number of branches or wyes, and (4) amount of other open lines throughout the system. Explaining how to calculate these variables is beyond the scope of this manual. Consult an expert or purchase a good dust collection "how-to" book.*

#### To connect a dust collection hose:

- Fit a 4" dust hose over each dust port, as shown in **Figure 13**, then secure them in place with hose clamps.
- Tug the hoses to make sure they do not come off. **Note:** A tight fit is necessary for proper performance.

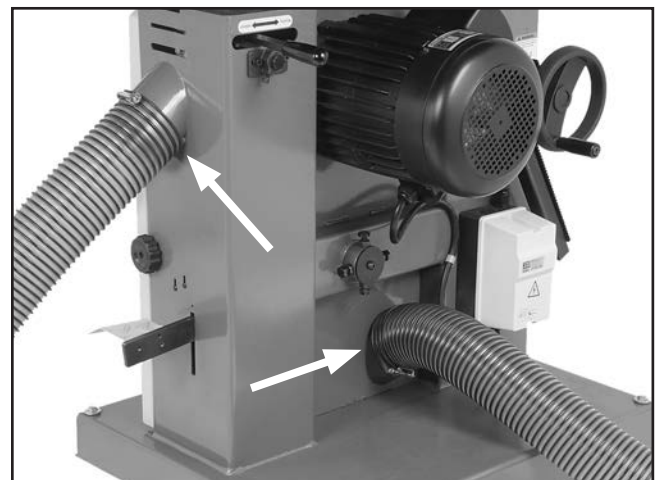

**Figure 13.** Dust hoses attached.



# Adjustment Overview

The bandsaw is one of the most versatile wood-working machines. However, it has multiple components that must be properly adjusted for the best cutting results.

For practical and safety reasons, some adjustments and test operations must be performed before performing other necessary adjustments. Below is an overview of the order in which they should be performed:

- Initial Blade Tracking
- Adjusting Positive Stop
- Test Run
- Tensioning Blade
- Aligning Blade Support Bearings
- Adjusting Blade Guide Bearings
- Aligning Table
- Aligning Fence
- Calibrating Miter Gauge
- Calibrating Fence Pointer

## Initial Blade Tracking

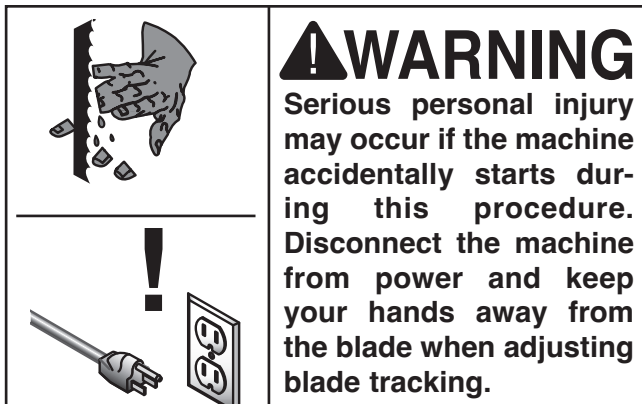

Blade tracking is affected by the tilt of the upper wheel (known as center tracking) and the alignment of both wheels (known as coplanar tracking).

The wheels on this bandsaw were aligned at the factory, so center tracking is the only adjustment that needs to be performed when the saw is new (refer to the **Aligning Wheels** subsection on **Page 64** for detailed instructions on coplanar tracking).

**Note:** Changes in the blade tension may change the blade tracking. For best performance, regularly check and maintain the proper blade tracking.

**To center track the blade:**

1. DISCONNECT MACHINE FROM POWER!
2. Adjust the upper and lower blade guides away from the blade (refer to **Adjusting Blade Guide Bearings** on **Page 28** for detailed instructions).

**Note:** When adjusting the blade tracking, the blade must have a reasonable amount of tension to simulate operating conditions. After the **Test Run** is successfully completed, you will perform a thorough version of the following steps to correctly tension the blade.

3. Move the blade tension quick release lever all the way right (as viewed from the rear of the machine) to apply tension to the blade (see **Figure 14**).

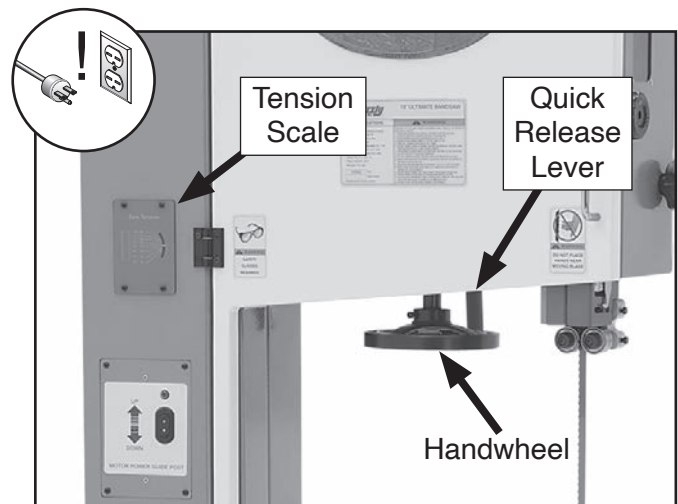
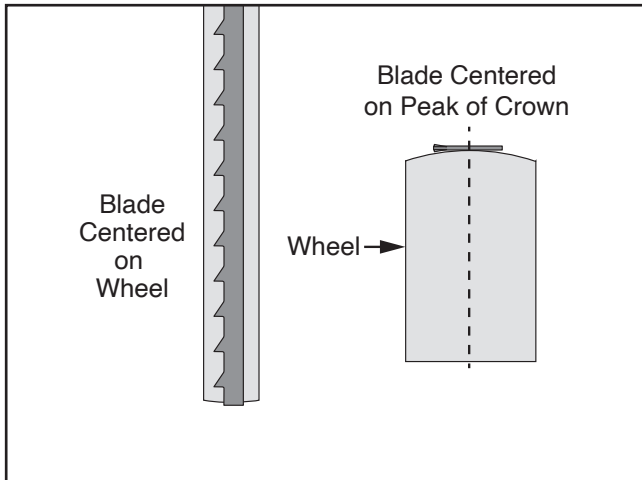

**Figure 14.** Blade tension controls.

4. Use the tension handwheel to bring the pointer on the tension scale to the appropriate mark for the blade width.



5. Open the upper wheel cover.
6. Rotate the upper wheel by hand several times (at least three) and watch how the blade rides on the wheel crown. See **Figure 15** for an illustration of this concept.



**Figure 15.** Blade center tracking profiles.

—If the blade rides in the center of the upper wheel and is centered on the peak of the wheel crown, then the bandsaw is already properly center-tracked and no further tracking adjustments are needed at this time.

—If the blade does NOT ride in the center of the upper wheel and is not centered on the peak of the wheel crown, then continue with this procedure.

7. Loosen the blade tracking lock lever so that the blade tracking knob can rotate (see **Figure 16**).



**Figure 16.** Blade tracking knob and lock lever.

**Note:** When the tracking knob is rotated, the lower portion of the upper wheel will tilt out or in, which affects the way the blade tracks.

8. Spin the upper wheel with one hand and slowly adjust the tracking knob with the other until the blade rides in the center of the wheel tire without wandering.
9. Tighten the lock lever to secure the setting, then spin the upper wheel again to confirm the tracking. If necessary, repeat **Steps 6–8** until you are satisfied with the blade tracking.
10. Re-adjust the blade guide bearings toward the blade (refer to **Page 28**).
11. Close and secure the upper wheel cover before beginning operation.

## Adjusting Positive Stop

After using the table at a tilt of other than 0°, the positive stop allows the table to be quickly and accurately returned to the horizontal position in relation to the blade. This is important for accurate cutting results.

### To correctly set the positive stop:

1. Correctly set the blade tension and use the guide post elevation control to move the guide post all the way up.
2. DISCONNECT MACHINE FROM POWER!



- Loosen the table tilt lock handle, then use the table tilt handwheel to raise the table (see **Figure 17**).

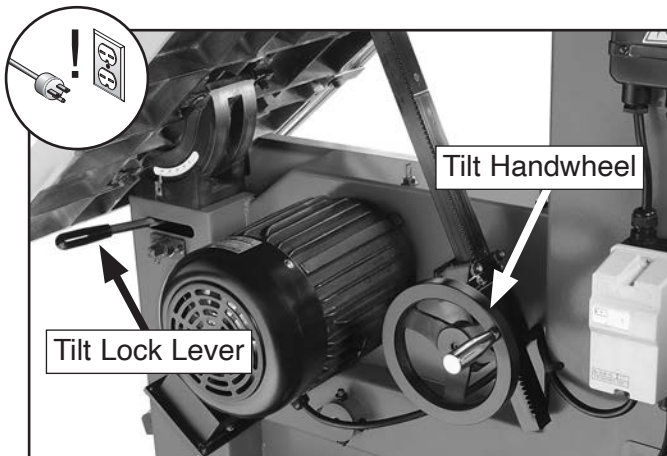

**Figure 17.** Table tilted up.

- Open both wheel covers, use a 17mm wrench to loosen the positive stop jam nut shown in **Figure 18**, then lower the positive stop bolt so that it will not interfere with the table tilt in the following steps.



**Figure 18.** Positive stop bolt and jam nut.

- Lower the table and place a machinist's square flat on the table and against the side of the blade, as illustrated in **Figure 19**.

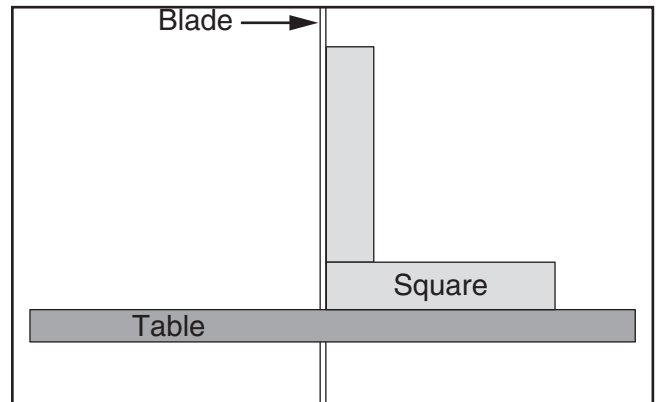

**Figure 19.** Squaring table to the blade.

- Use the table tilt handwheel to adjust the table square to the blade, then move the tilt lock lever to the right to secure the setting.
- Adjust the positive stop bolt up until it just touches the table, then re-tighten the jam nut to hold it in place.
- Re-check the table to make sure it is square to the blade. If necessary, repeat this procedure until you are satisfied.
- Loosen the screw on the table tilt scale pointer, but do not remove it (see **Figure 20**).

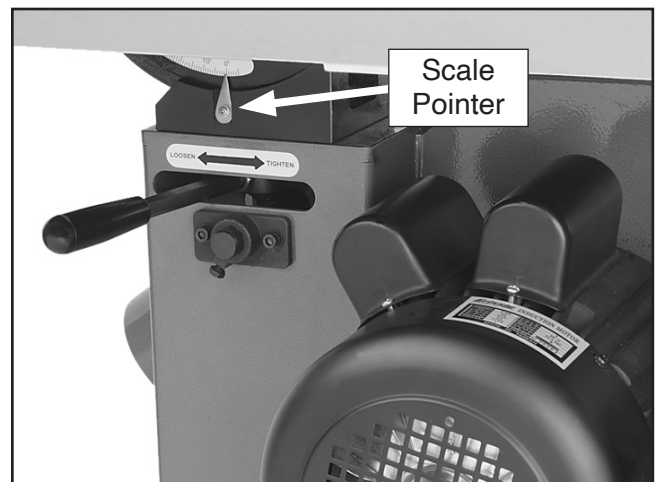

**Figure 20.** Table tilt scale pointer.

- Align the pointer tip with the zero on the scale, then re-tighten the screw.
- Close and secure both wheel covers before beginning operation.



# Test Run

Once assembly is complete, test run the machine to ensure it is properly connected to power and safety components are functioning correctly.

If you find an unusual problem during the test run, immediately stop the machine, disconnect it from power, and fix the problem BEFORE operating the machine again. The **Troubleshooting** table in the **SERVICE** section of this manual can help.

The test run consists of verifying the following:

1. The motor powers up and runs correctly.
2. The stop button and key switch safety features work correctly.
3. The guide post elevation motor powers up and runs correctly.
4. The foot brake operates correctly.
5. The upper wheel cover safety switch operates correctly.

## **!WARNING**

**Before starting the bandsaw, make sure you have performed the preceding assembly and adjustment instructions, and you have read through the rest of the manual and are familiar with the various functions and safety features on this machine. Failure to follow this warning could result in serious personal injury or even death!**

**To test run the machine:**

1. Make sure you understand the safety instructions at the beginning of the manual and that the machine is set up properly.
2. Make sure all tools and objects used during setup are cleared away from the machine and that nothing obstructs the blade movement.
3. Make sure both wheel covers are closed and secured.
4. Connect the machine to the power source.

5. Push the OFF button in, then twist it clockwise so it pops out. When the OFF button pops out, the switch is reset and ready for operation (see **Figure 21**).

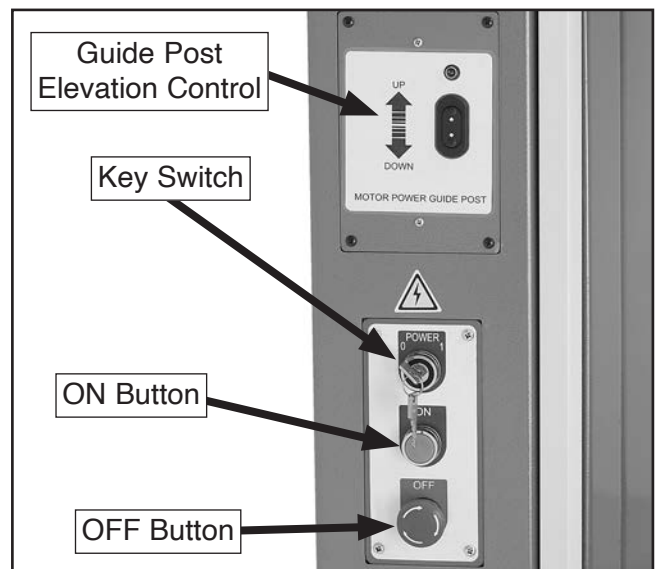

**Figure 21.** Resetting the OFF button.

6. Verify that the machine is operating correctly by turning the key switch to "1" (see **Figure 22**), then pushing the ON button.

—When operating correctly, the machine runs smoothly with little or no vibration or rubbing noises.

—Investigate and correct strange or unusual noises or vibrations before operating the machine further. Always disconnect the machine from power when investigating or correcting potential problems.



**Figure 22.** Control panel.



7. Press the OFF button to stop the machine.
8. WITHOUT resetting the OFF button, press the ON button. The machine should not start.
  - If the machine does not start, the OFF button safety feature is working correctly.
  - If the machine does start (with the stop button pushed in), immediately disconnect the machine from power. The OFF button safety feature is not working correctly. This safety feature must work properly before proceeding with regular operations. Call Tech Support for help.
9. Reset the OFF button, turn the key switch to "0", then press the ON button. The machine should not start.
  - If the machine does not start, the key switch safety feature is working correctly.
  - If the machine does start (with the key switch turned to "0"), immediately press the OFF button and disconnect the machine from power. The key switch safety feature is not working correctly. This safety feature must work properly before proceeding with regular operations. Call Tech Support for help.
10. Turn the key switch back to "1", then use the guide post elevation control to raise and lower the guide post (see **Figure 22**).
 

**Note:** *When the foot brake is used, a "kill" switch stops the flow of power to the machine. It is the steady pressure on the foot brake that quickly brings the blade to a full stop.*
11. Start the machine, then apply steady pressure to the foot brake.
  - If the machine turns **OFF** and the blade comes to a rapid stop, the foot brake system is working properly.
  - If the machine does NOT turn **OFF**, the foot brake system is not working correctly. Immediately press the OFF button and disconnect the machine from power. This safety feature must work properly before proceeding with regular operations. Call Tech Support for help.
12. Press the OFF button, wait for the blade to come to a complete stop, then open the upper wheel cover approximately 1" to activate the safety switch.
 

**Note:** *This safety switch is designed to interrupt power to the motors when the door is open.*
13. While standing to the left of the machine and away from the open wheel cover, reset the OFF button and press the ON button. The machine should NOT start.
  - If the machine does not start, the upper wheel cover safety switch feature is working correctly. The **Test Run** is complete.
  - If the machine does start, immediately press the OFF button and disconnect the machine from power. The upper wheel cover safety switch is not working correctly. This safety feature must work properly before proceeding with regular operations. Call Tech Support for help.



# Tensioning Blade

A properly tensioned blade is essential for making accurate cuts, maximizing blade life, and making other bandsaw adjustments. However, a properly tensioned blade will not compensate for cutting problems caused by excessive feed rate, hardness variations between workpieces, and improper blade selection.

Optimal cutting results for any type of workpiece are achieved through a combination of correct blade selection, proper blade tension, properly adjusted blade guides and other bandsaw components, and using an appropriate feed rate.

Improper blade tension is unsafe, produces inaccurate and inconsistent results, and introduces unnecessary wear on bandsaw components. Over-tensioning the blade increases the chance of the blade breaking or wheel misalignment. Under-tensioned blades wander excessively while cutting and will not track properly during operation.

The method used to tension the blade is often a matter of preference. This manual describes two methods: the flutter method and the deflection method. Either method will help you properly tension the blade. Experience and personal preference will help you decide which method you prefer.

**Note:** *Tensioning the blade before the **Test Run** was an approximate tension. The following procedures fine-tune the blade tension.*

## Flutter Method

Using the flutter method, you intentionally loosen the blade until it just passes the point of being too loose (when it begins to flutter). Then you gradually tighten the blade until proper tension is reached.

**To tension bandsaw blade using flutter method:**

1. DISCONNECT MACHINE FROM POWER!
2. Make sure blade is tracking properly as instructed in **Initial Blade Tracking** on **Page 19**.

3. Use the guide post elevation control to raise the guide post all the way up, then move the upper and lower guide/support bearings as far away from the blade as possible (refer to **Adjusting Blade Guide Bearings** on **Page 28** for detailed instructions).

**Note:** *This procedure will NOT work correctly if the guide/support bearings are in contact with the blade.*

4. Move the blade tension quick release lever all the way to the right (as viewed from the rear of the machine) to apply tension, then rotate the tension handwheel until the mark on the blade tension scale matches the one for the blade width (see **Figure 23**).

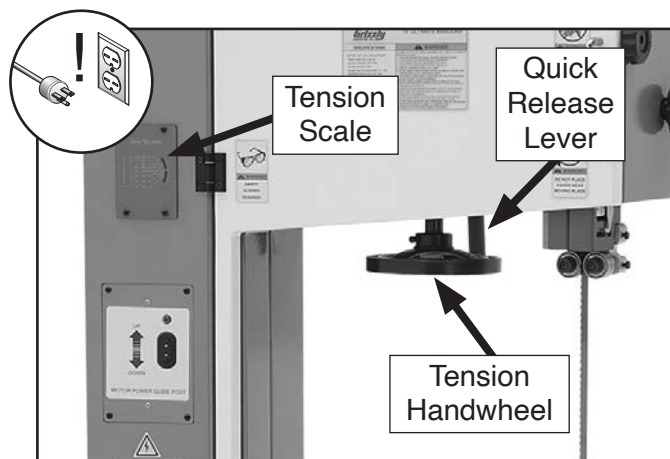

**Figure 23.** Blade tension controls.

5. Turn the bandsaw **ON** and wait for the blade to reach full speed.
6. Decrease blade tension very slowly by rotating the tension handwheel counterclockwise (as viewed from above) until the blade just starts to flutter or vibrate, then stop decreasing the tension.
7. Now, increase the tension by rotating the handwheel in the opposite direction (clockwise) until the blade stops fluttering, then rotate the handwheel another  $\frac{1}{4}$  turn clockwise.
8. Turn the bandsaw **OFF**.
9. Re-adjust the blade tracking (**Page 19**) and the blade guides (refer to **Page 28**).



## Deflection Method

The deflection method is much more subjective than the flutter method. Each blade will deflect differently and every user will determine what "moderate pressure" means. The following are general guidelines for tensioning the blade with this method.

### To tension bandsaw blade using deflection method:

1. DISCONNECT MACHINE FROM POWER!
2. Make sure blade is tracking properly as instructed in **Initial Blade Tracking** on **Page 19**.
3. Use the guide post elevation control to raise the guide post all the way up, then move the upper and lower guide/support bearings as far away from the blade as possible (refer to **Adjusting Blade Guide Bearings** on **Page 28** for detailed instructions).
4. Move the blade tension quick release lever all the way to the right (as viewed from the rear of the machine) to apply tension, then rotate the tension handwheel until the mark on the blade tension scale matches the one for the blade width (see **Figure 23**).
5. Using moderate pressure, push center of blade sideways.
  - If blade deflects approximately  $\frac{1}{4}$ ", it is properly tensioned. Proceed to **Step 6**.
  - If blade deflects less than  $\frac{1}{4}$ ", it is over-tensioned. Rotate blade tension handwheel counterclockwise two full turns and repeat **Step 5**.
  - If blade deflects  $\frac{1}{4}$ " or more, blade is not properly tensioned. Rotate blade tension handwheel clockwise to incrementally tension blade, and repeat **Step 5** until blade is properly tensioned.
6. Adjust blade guides as described in **Aligning Blade Support Bearings** on **Page 25** and **Adjusting Blade Guide Bearings** on **Page 28**.

# Aligning Blade Support Bearings

Proper alignment of the blade guide and support bearings with the blade is an important part of making accurate cuts. When correctly aligned, the guide bearings support but do not contact the blade teeth, and the support bearing keeps the blade from deflecting backwards with the force of cut.

## Upper Blade Bearings

1. Make sure the blade is properly tensioned (**Page 24**) and tracking correctly (**Page 19**).
2. DISCONNECT MACHINE FROM POWER!
3. Familiarize yourself with the upper blade bearing controls shown in **Figures 24–25**.

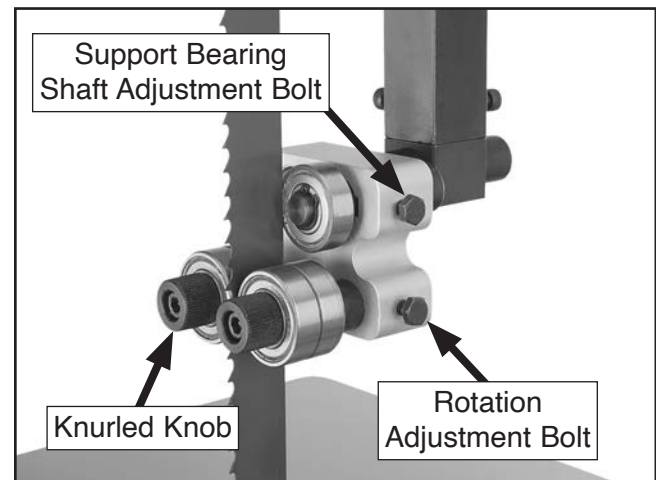

**Figure 24.** Front upper blade guide controls.

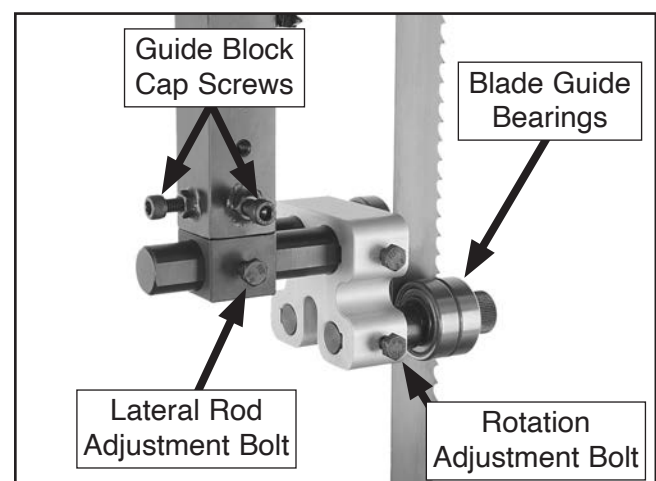

**Figure 25.** Rear upper blade guide controls.



**Note:** If you choose, you can remove the two lower cap screws and the upper hex bolt that secure the blade guard, then have another person hold the guard out of the way while you adjust the upper blade guide and support bearings.

Make sure to firmly secure the blade guard in place when you have completed the adjustment.

4. Loosen the rotation adjustment bolts, then use the knurled knobs to move the guide bearings away from the blade.
5. Loosen the guide block cap screws, then rotate the blade guide assembly side to side until the face of the support bearing is perpendicular ( $90^\circ$ ) to the blade, as illustrated in **Figure 26**.

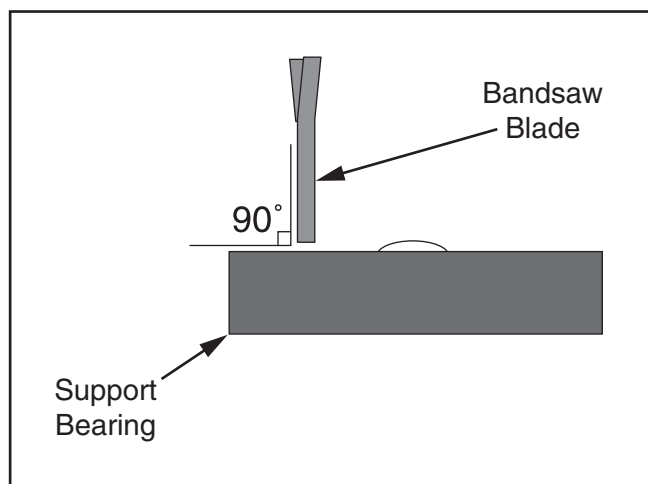
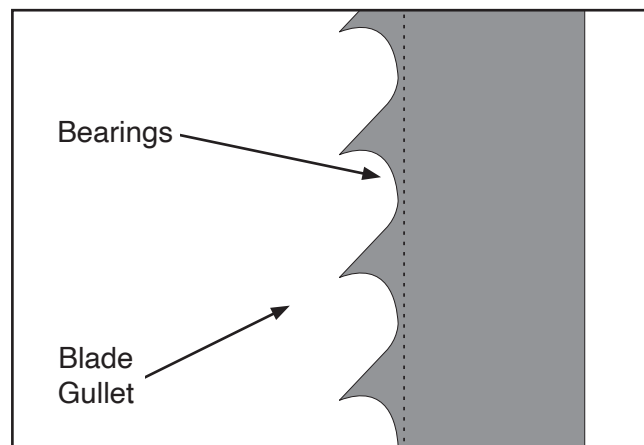

**Figure 26.** Support bearing  $90^\circ$  to the blade.

6. Re-tighten the guide block cap screws to secure the support bearing position.
7. Loosen the support bearing shaft adjustment bolt and the lateral rod adjustment bolt (see **Figures 24–25**).

8. Adjust the blade guide bearings until the edges of the bearings are  $\frac{1}{64}$ " (approximately the thickness of four pieces of paper) behind the blade gullets, as illustrated in **Figure 27**.

**Note:** With larger blades it may not be possible to reach the  $\frac{1}{64}$ " spacing. In this case, adjust the bearings as far forward to the blade gullets as possible.



**Figure 27.** Lateral adjustment of guide bearings.

9. Position the support bearing so that it is  $\frac{1}{64}$ " (approximately the thickness of four pieces of paper) behind the blade, as illustrated in **Figure 28**.

**Note:** The goal is to position the support bearing so it will support the blade when pressure is applied during the cutting operation.

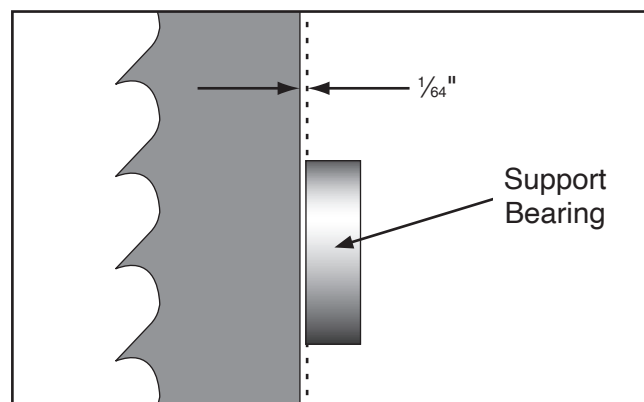

**Figure 28.** Support bearing properly positioned behind the blade.



10. Re-tighten the support bearing shaft adjustment bolt and the rotation adjustment bolts to secure the bearings in place.
11. Properly adjust the guide bearings (refer to **Adjusting Blade Guide Bearings** beginning on **Page 28** for detailed instructions).

## Lower Blade Bearing

1. Make sure the blade is properly tensioned (**Page 24**) and tracking correctly (**Page 19**).
2. DISCONNECT MACHINE FROM POWER!
3. Open both wheel covers, then familiarize yourself with the lower blade bearing controls shown in **Figures 29–31**.

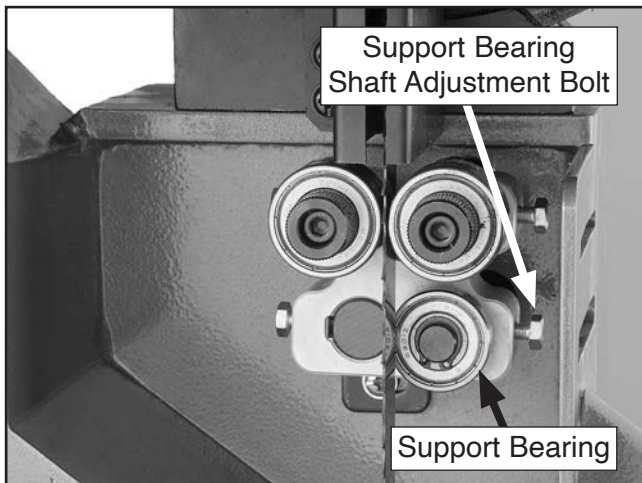

**Figure 29.** Lower support bearing controls.

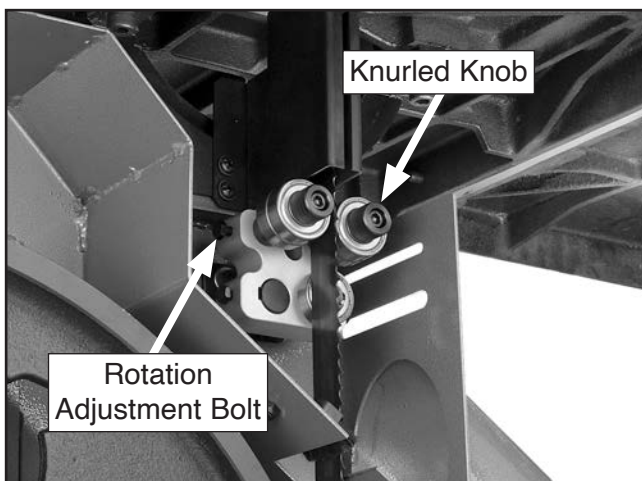

**Figure 30.** Front lower blade guide controls.

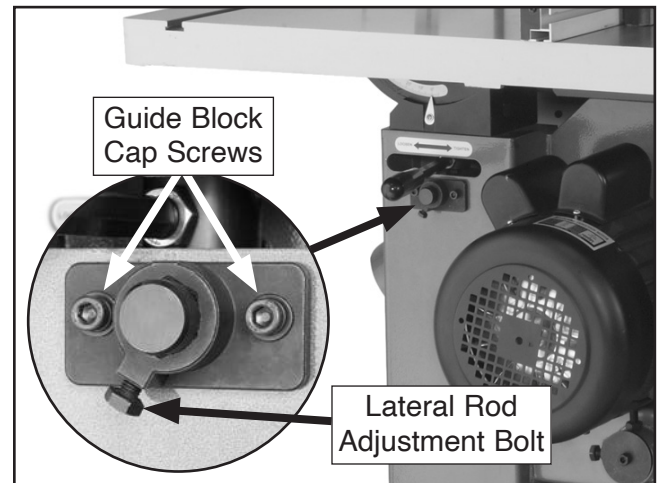

**Figure 31.** Rear lower blade guide controls.

4. To adjust the lower blade bearings, follow the same procedure used for the upper blade bearings beginning on the previous page.
5. Close and secure the lower and upper wheel covers.



# Adjusting Blade Guide Bearings

When properly adjusted to the blade, the upper and lower blade guide bearings provide side-to-side support that keeps the blade straight while cutting.

Items Needed	Qty
Hex Wrench 5mm.....	1
Adjustable Wrench or Socket.....	1

## Upper Blade Guide Bearings

1. Make sure the blade is properly tensioned (**Page 24**) and the blade tracking is correctly (**Page 19**).
2. DISCONNECT MACHINE FROM POWER!
3. Make sure the blade guide and support bearings are properly aligned with the blade, as instructed on **Page 25**.
4. Familiarize yourself with the upper blade bearing controls shown in **Figures 32–33**.

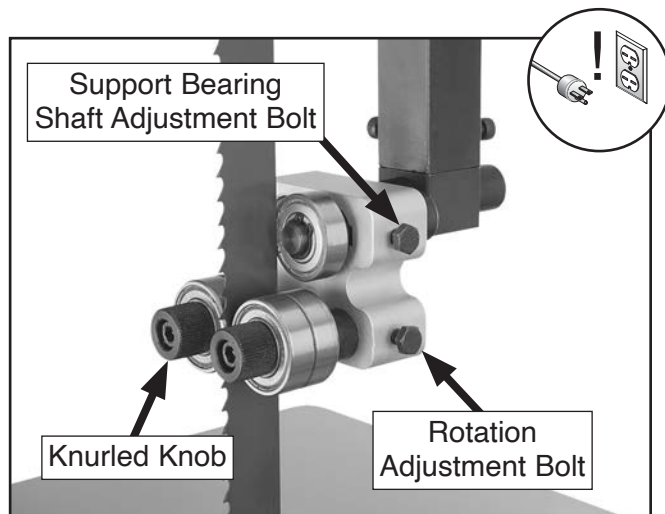

**Figure 32.** Front upper blade guide controls (blade guard removed for photo clarity).

**Note:** If you choose, you can remove the two lower cap screws and the upper hex bolt that secure the blade guard, then have another person hold the guard out of the way while you adjust the upper blade guide and support bearings.

Make sure to firmly secure the blade guard in place when you have completed the adjustment.

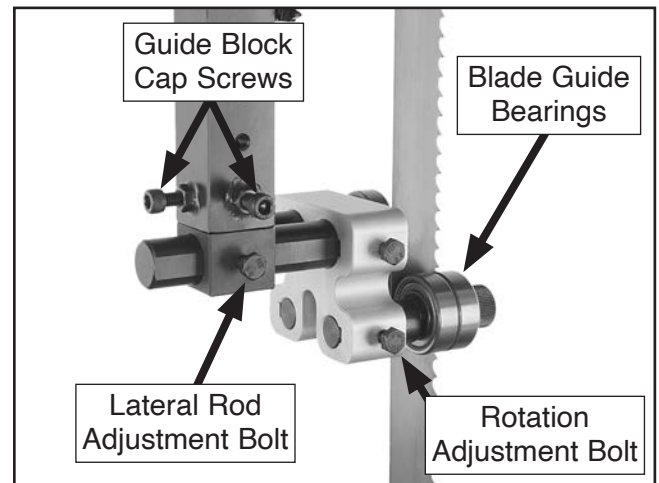

**Figure 33.** Rear upper blade guide controls (blade guard removed for photo clarity).

5. Loosen the rotation adjustment bolts on both sides of the blade (see **Figures 32–33**).
6. Rotate the knurled knobs (see **Figure 32**) to position the bearings as close to the blade as possible without touching it.

**Note:** Ideally, the bearings should be approximately 0.004" away from the blade, which is approximately the thickness of a sheet of paper.

7. Re-tighten both rotation adjustment bolts to secure the blade bearings in place.



## Lower Blade Guide Bearings

1. Make sure the blade is properly tensioned (**Page 24**) and tracking correctly (**Page 19**).
2. DISCONNECT MACHINE FROM POWER!
3. Make sure the blade guide and support bearings are properly aligned with the blade, as instructed on **Page 25**.
4. Familiarize yourself with the lower blade bearing controls shown in **Figure 34**.

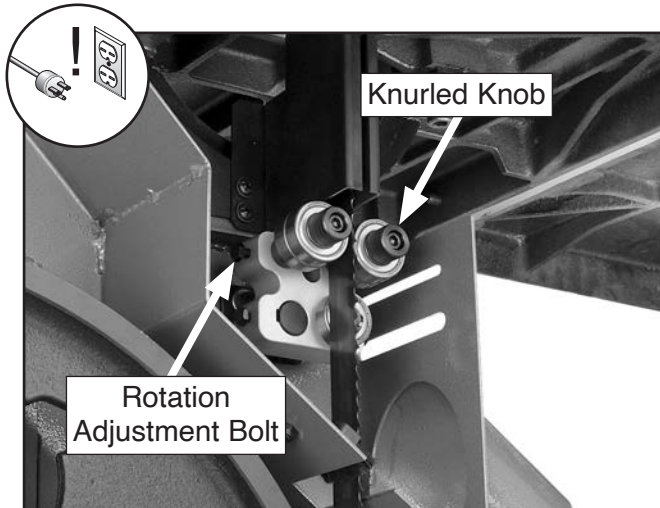

**Figure 34.** Front lower blade guide controls.

5. Open both wheel covers.
6. To adjust the lower blade guide bearings, follow the same procedure used for the upper blade guide bearings on the previous page.

## Aligning Table

To ensure cutting accuracy with the miter gauge and fence, the table must be aligned with the blade. This is a process of aligning the table miter slot so that it is parallel with the blade, and is best done with a wide blade (1" or more).

### Items Needed

	Qty
Straightedge 3' .....	1
Hex Wrench 8mm.....	1

### To align the table with the blade:

1. Make sure the blade is properly tensioned (**Page 24**) and tracking correctly (**Page 19**).
2. DISCONNECT MACHINE FROM POWER!
3. Place the straightedge flat on the table and across the blade so that it lightly touches both the front and back of the blade without touching a tooth, as shown in **Figure 35**.

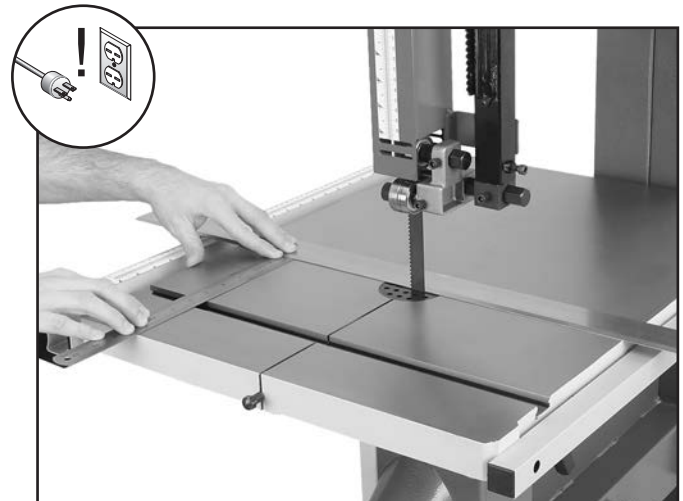

**Figure 35.** Example of measuring the table miter slot to be parallel with the blade.



- Use the finely incremented ruler and record the distance between the miter slot and the front and back of the straightedge.

- If the distances are the same, no further adjustments are needed.

- If there is a difference between the distances from the miter slot and the straightedge, continue with this procedure.

- From underneath the table, loosen the four trunnion cap screws that secure the table (see **Figure 36**).

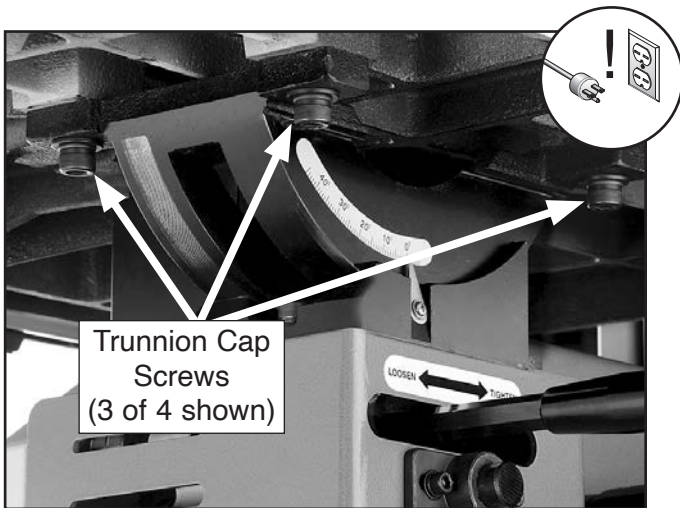

**Figure 36.** Trunnion cap screws (3 of 4 shown).

- Shift the table until the distances between the miter slot and straightedge are equal, as measured in **Step 4**.
- Re-tighten the trunnion cap screws, then repeat **Step 4**. If necessary, repeat **Steps 4–6** until you are satisfied.

## Aligning Fence

The fence must be aligned with the blade to ensure accurate cutting results. This is best done by aligning the fence with the miter slot after the table is properly aligned.

Items Needed	Qty
Hex Wrench 6mm.....	1

### To align the fence with the table:

- Make sure the blade is properly tensioned (**Page 24**) and tracking correctly (**Page 19**).
- DISCONNECT MACHINE FROM POWER!
- Make sure the table is properly aligned with the blade, as instructed in the previous subsection.
- If attached, remove the resaw fence.
- Mount the fence on the right side of the blade and even with the miter slot, as shown in **Figure 37**.

- If the fence face is even with the miter slot from front-to-back, no further adjustments are necessary.

- If fence face is not even with miter slot along its length, continue with this procedure.



**Figure 37.** Fence even with the miter slot.



- Loosen the cap screws that secure the fence rail to the table (see **Figure 38**).

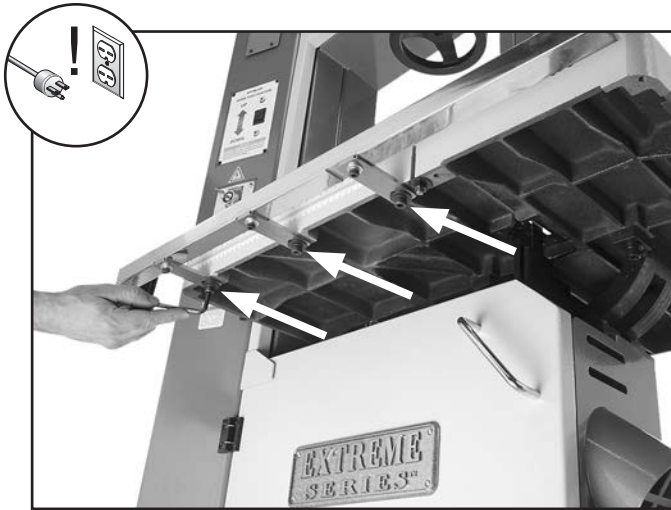

**Figure 38.** Fence rail cap screws.

- With the fence locked onto the fence rail, shift the fence rail until the fence is even with the miter slot along its entire length, then re-tighten the rail cap screws.
- Slide the fence along the entire length of the rail to make sure it does not bind against the table.
  - If the fence does bind against the table, re-loosen the rail cap screws and pull the rail away from the table, then repeat **Steps 7–8**.

## Calibrating Miter Gauge

To ensure accurate cutting results when using the miter gauge, the miter gauge body must be aligned with the blade.

<b>Items Needed</b>	<b>Qty</b>
Phillips Head Screwdriver.....	1
Machinist's Square .....	1

### To align the miter gauge body:

- Make sure the blade is properly tensioned (**Page 24**) and tracking correctly (**Page 19**).
- Install the widest blade possible and correctly tension it.
- DISCONNECT MACHINE FROM POWER!**
- Lay the machinist's square flat on the table and up against the blade without touching any blade teeth, as shown in **Figure 39**.
- Without moving the square, bring the miter gauge body up to the square, as shown in **Figure 39**.
  - If there are no gaps between the miter gauge body and the square, no further adjustments are needed.
  - If there are gaps between the miter gauge body and the square, continue with this procedure.

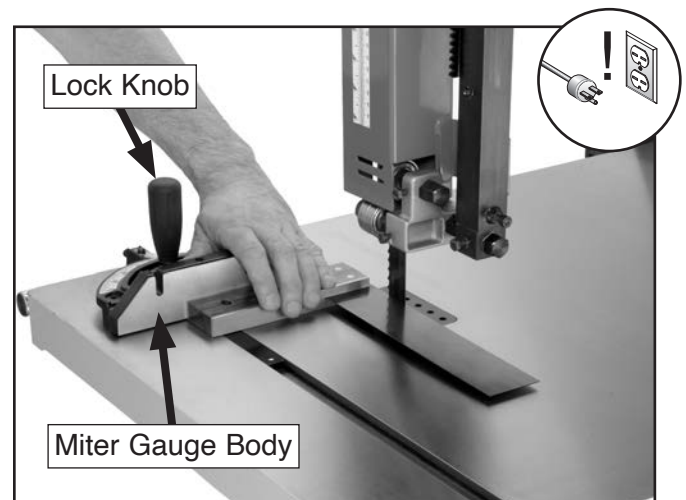

**Figure 39.** Aligning the miter gauge body with the blade.

- Loosen the miter gauge lock knob and rotate the gauge body until it is flat against the square, then re-tighten the lock knob.
- Loosen the screw that secures the miter gauge pointer, set the pointer to the 0° mark on the scale, then re-tighten the screw.



# Calibrating Fence Pointer

After the fence is properly aligned with the table, which is aligned with the blade, the fence pointer must be calibrated to ensure quick and accurate positioning of the fence.

Items Needed	Qty
Phillips Head Screwdriver.....	1

## To calibrate the fence pointer:

1. Make sure the blade is properly tensioned (Page 24).
2. DISCONNECT MACHINE FROM POWER!
3. Position the fence against the left side of the blade so that it is touching the blade without applying pressure to it, as shown in Figure 40, then lock the fence in place.



Figure 40. Fence against the blade.

4. Loosen the pointer adjustment screw shown in Figure 41, set the pointer in line with the "0" mark on the scale, then re-tighten the screw.

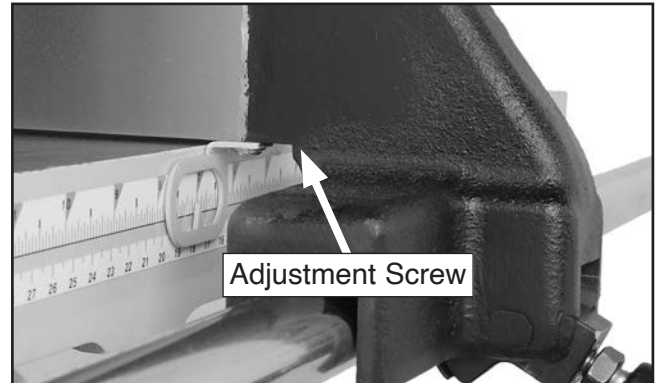

Figure 41. Fence pointer.





# SECTION 4: OPERATIONS

## Operation Overview

The purpose of this overview is to provide the novice machine operator with a basic understanding of how the machine is used during operation, so the machine controls/components discussed later in this manual are easier to understand.

Due to the generic nature of this overview, it is **not** intended to be an instructional guide. To learn more about specific operations, read this entire manual, seek additional training from experienced machine operators, and do additional research outside of this manual by reading "how-to" books, trade magazines, or websites.

	<p><b>! WARNING</b> To reduce your risk of serious injury, read this entire manual <b>BEFORE</b> using machine.</p>
--	---

<p><b>! WARNING</b> To reduce risk of eye injury from flying chips or lung damage from breathing dust, always wear safety glasses and a respirator when operating this machine.</p>	
	

<p><b>NOTICE</b> If you are not experienced with this type of machine, WE STRONGLY RECOMMEND that you seek additional training outside of this manual. Read books/magazines or get formal training before beginning any projects. Regardless of the content in this section, Grizzly Industrial will not be held liable for accidents caused by lack of training.</p>
---

To complete a typical operation, the operator does the following:

1. Examines workpiece to make sure it is suitable for cutting.
2. Adjusts table tilt, if necessary, to correct angle of desired cut.
3. If using fence, adjusts it for width of cut and then locks it in place. If using miter gauge, adjusts angle and locks it in place.
4. Loosens guide post lock knob, adjusts blade guide height to between 1/4" and 1" from top of workpiece using guide post elevation control, then tightens guide post lock knob.
5. Checks to make sure workpiece can safely pass all the way through the blade without interference from other objects.
6. Puts on safety glasses and a respirator.
7. Starts dust collector and bandsaw.
8. Holds workpiece firmly and flatly against both table and fence (or miter gauge), and then pushes workpiece into blade at a steady and controlled rate until cut is complete.  
  
Operator is very careful to keep fingers away from blade and uses a push stick to feed narrow workpieces.
9. Stops bandsaw.



## Basic Functions of a Bandsaw

A properly adjusted bandsaw can be safer to operate than most other saws and performs many types of cuts with ease and accuracy. It is capable of performing the following types of cuts:

### Straight Cuts

- Mitters
- Angles
- Compound Angles
- Resawing
- Ripping
- Crosscutting

### Irregular Cuts

- Simple and Complex Curves
- Duplicate Parts
- Circles
- Beveled Curves

## Basic Cutting Tips

Here are some basic tips to follow when operating the bandsaw:

- Replace, sharpen, and clean blades often for best performance. Check guides, tension, and alignment settings periodically and adjust when necessary to keep the saw running in top condition.
- Use light and even pressure while cutting. Light feeding pressure makes it easier to cut straight and prevents undue friction or strain on the bandsaw components and the blade.
- Avoid twisting the blade when cutting around tight corners. Allow the blade to saw its way around the corners. Always use relief cuts when possible.
- Misusing the saw or using incorrect techniques (e.g. twisting the blade with the workpiece, incorrect feed rate, etc.) is unsafe and results in poor cuts.

# Workpiece Inspection

---

Some workpieces are not safe to cut or may require modification before they are safe to cut.

**Before cutting, inspect all workpieces for the following:**

- **Material Type:** This machine is intended for cutting natural and man-made wood products, laminate covered wood products, and some plastics. Cutting drywall or cementitious backer board creates extremely fine dust and may reduce the life of the bearings. This machine is NOT designed to cut metal, glass, stone, tile, etc.; cutting these materials with a bandsaw may lead to injury.
- **Foreign Objects:** Nails, staples, dirt, rocks and other foreign objects are often embedded in wood. While cutting, these objects can become dislodged and hit the operator, cause kickback, or break the blade, which might then fly apart. Always visually inspect your workpiece for these items. If they can't be removed, DO NOT cut the workpiece.
- **Large/Loose Knots:** Loose knots can become dislodged during the cutting operation. Large knots can cause kickback and machine damage. Choose workpieces that do not have large/loose knots or plan ahead to avoid cutting through them.
- **Wet or "Green" Stock:** Cutting wood with a moisture content over 20% causes unnecessary wear on the blades, increases the risk of kickback, and yields poor results.
- **Excessive Warping:** Workpieces with excessive cupping, bowing, or twisting are dangerous to cut because they are unstable and often unpredictable when being cut. DO NOT use workpieces with these characteristics!
- **Minor Warping:** Workpieces with slight cupping can be safely supported if the cupped side is facing the table or the fence. On the contrary, a workpiece supported on the bowed side will rock during a cut and could cause kickback or severe injury.



# Operating Foot Brake

The Model G0701 is equipped with a foot brake (see **Figure 42**). Use the brake to cut power to the motor and bring the blade to a halt.

## NOTICE

The foot brake will not stop the bandsaw wheels and blade instantly. **DO NOT** become over confident and relax your safety awareness because of the foot brake feature. Make sure the bandsaw blade has stopped moving completely before leaving the machine.



**Figure 42.** Foot brake location.

# Table Tilt

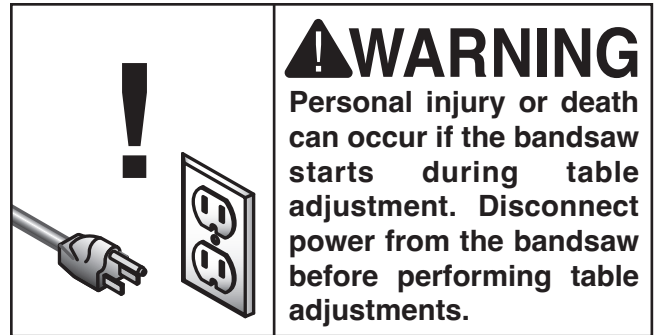

The bandsaw table will tilt 5° left and 45° right to provide a wide range of cutting options.

### To tilt the table:

1. DISCONNECT MACHINE FROM POWER!
2. Loosen the table tilt lock handle shown in **Figure 43**.
3. To tilt the table to the right, turn the table tilt handwheel clockwise (see **Figure 43**).

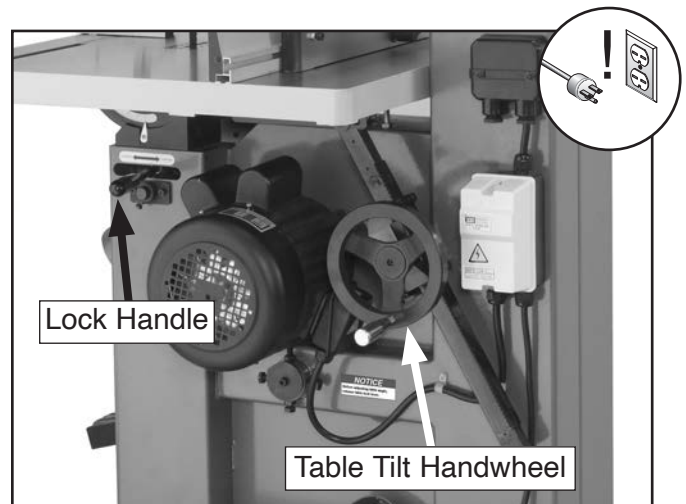

**Figure 43.** Table tilt controls.

4. To tilt the table to the left, turn the table tilt handwheel clockwise one turn, lower the positive stop bolt, then turn the handwheel counterclockwise.
5. Secure the table tilt lock handle.
6. Follow "Positive Stop" instructions on **Page 20** for resetting the stop bolt and table for horizontal (0°) operations.



# Guide Post

The motorized guide post (see **Figure 44**) moves the blade guide assembly up or down. To cut accurately and safely, the bottom of the blade guide assembly must be no more than 1" above the workpiece during cutting operations—this positioning provides the greatest blade support and minimizes the length of moving blade that is exposed to the operator.

## To adjust the guide post:

1. DISCONNECT MACHINE FROM POWER!
2. Make sure that the blade tension, blade tracking, support bearings, and blade guides are adjusted correctly.
3. Loosen guide post lock knob shown in **Figure 44**.

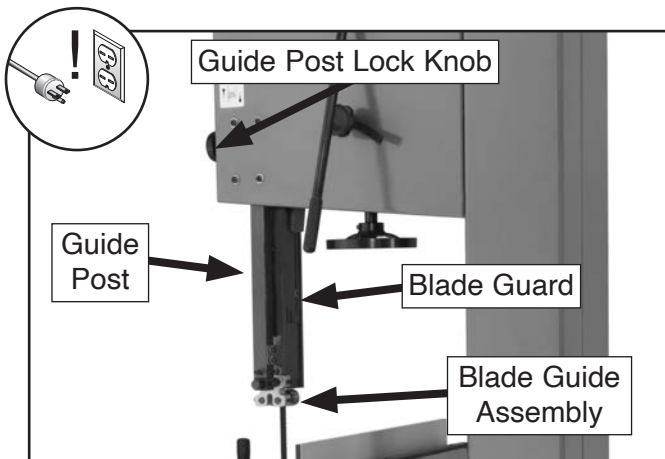

**Figure 44.** Guide post controls.

4. Press the guide post elevation control to raise or lower the guide post until the upper blade guide assembly is between ¼" and 1" from the top of the workpiece.
5. Lock guide post in place with the lock knob.

## **!WARNING**

**NEVER** place fingers or hands under the motorized blade guide assembly. Your hand could be crushed or stuck between the blade guides and the workpiece. Failure to follow these warnings may result in serious personal injury!

# Fine Tune Tracking

## **NOTICE**

Adjusting the final blade tracking setting requires the machine to be turned **ON**.

## To fine tune the tracking:

1. Close the wheel covers and turn the bandsaw **ON**.
2. Observe the blade tracking path through the clear window on the right side of the bandsaw, as shown in **Figure 45**.

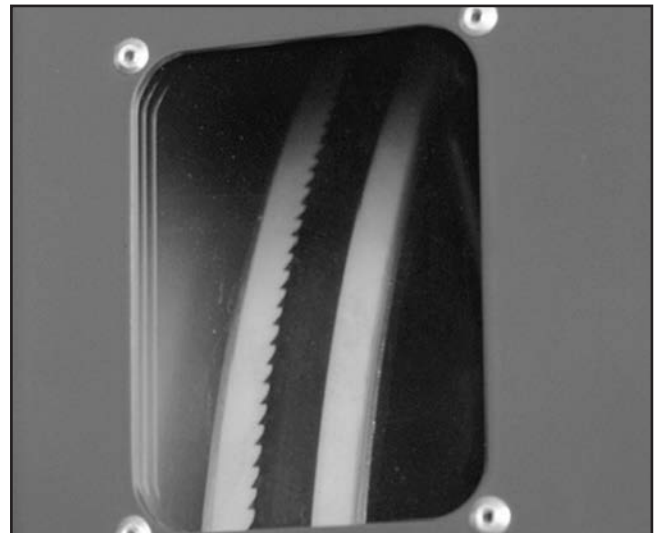

**Figure 45.** Blade tracking window.

3. Loosen the blade tracking lock lever.
4. Using the tracking controls (**Page 5, Figure 2**), adjust the blade so it tracks on the center of the wheel.
5. Tighten the blade tracking lock lever.



# Blade Selection

Selecting the right blade for the cutting task requires knowledge about blade characteristics and cutting priorities (i.e. speed, finish, etc.).

## Blade Terminology

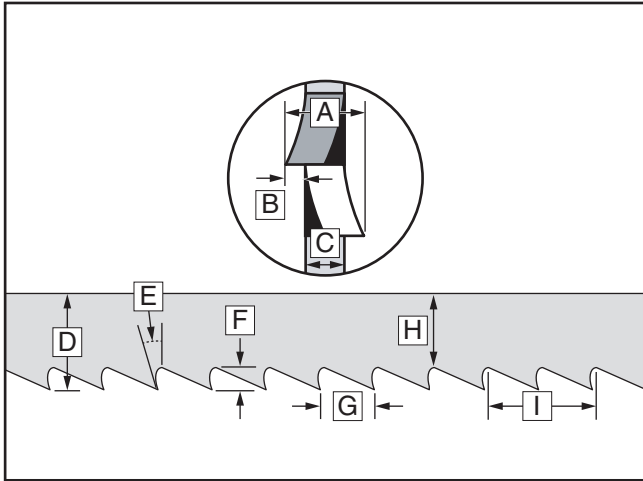

**Figure 46.** Bandsaw blade components.

- A. Kerf:** The amount of material removed by the blade during cutting.
- B. Tooth Set:** The amount each tooth is bent left or right along the blade.
- C. Gauge:** The thickness of the blade.
- D. Blade Width:** The widest point of the blade measured from the tip of the tooth to the back edge of the blade.
- E. Tooth Rake:** The angle of the tooth face from a line perpendicular to the length of the blade.
- F. Gullet Depth:** The distance from the tooth tip to the bottom of the curved area (gullet).
- G. Tooth Pitch:** The distance between tooth tips.
- H. Blade Back:** The distance between the bottom of the gullet and the back edge of the blade.
- I. TPI:** The number of teeth per inch measured from gullet to gullet.

## Blade Dimensions

Length Range..... 166"–168"  
 Width Range.....  $\frac{3}{8}$ "– $1\frac{3}{8}$ "

## Blade Length

Measured by the blade circumference, blade lengths are specific to each bandsaw. They are determined by the wheel diameter and distance between the wheels. Blades will vary slightly even in the same length because of how they are welded. Refer to the **Accessories** section later in this manual for blade replacements from Grizzly.

## Blade Width

Measured from the back of the blade to the tip of the blade tooth (the widest point), blade width is often the first consideration given to blade selection. Blade width dictates the largest and smallest curve that can be cut, as well as how accurately it can cut a straight line.

- **Curve Cutting:** Use the chart in **Figure 47** to determine the correct blade for curve cutting. Determine the smallest radius curve that will be cut on your workpiece and use the corresponding blade width (refer to **Cutting Curves** on **Page 45** for more information).

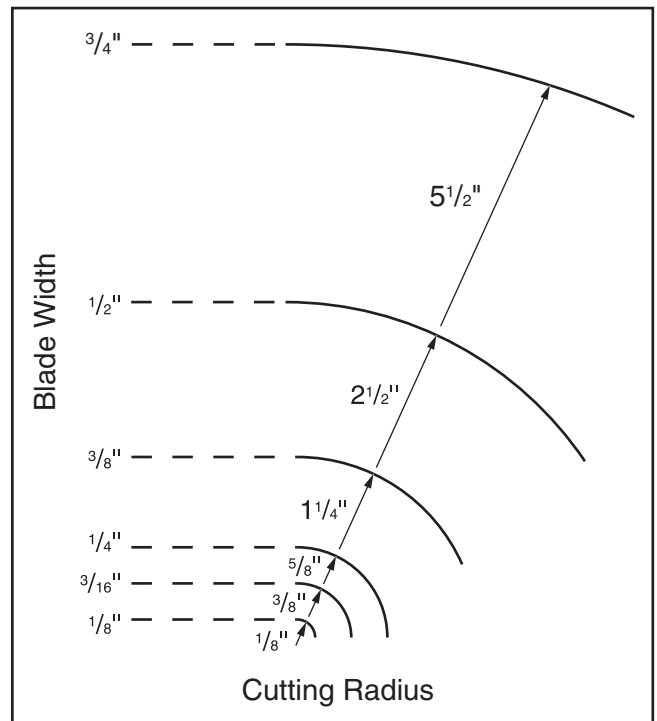

**Figure 47.** Recommended cutting radius per blade width.



- **Straight Cutting:** Use the largest width blade that you own. Large blades excel at cutting straight lines and are less prone to wander (known as blade lead—refer to **Page 58** for more information on blade lead).

## Tooth Style

**Figure 48** illustrates the three main blade tooth styles:

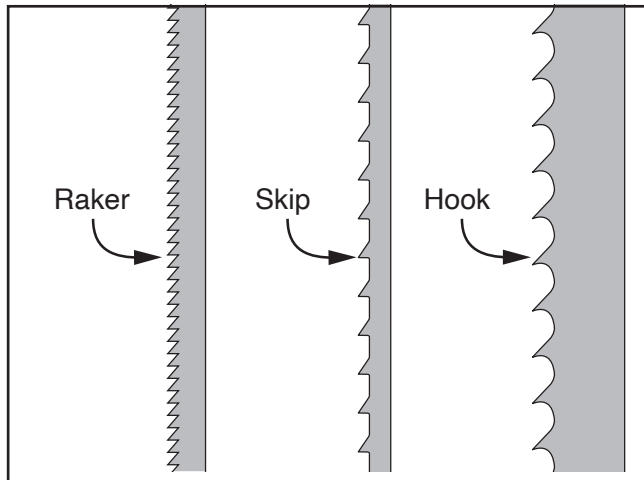

**Figure 48.** Main blade tooth styles.

- **Raker:** Considered to be the standard because the tooth size and shape are the same as the tooth gullet. The teeth on raker blades usually are very numerous, have no angle, and produce cuts by scraping the material. As a result, smooth cuts can be achieved without cutting fast or generating more heat than other tooth types.
- **Skip:** Similar to a raker blade that is missing every other tooth. Because of the design, skip-toothed blades have a much larger gullet than raker blades, and therefore, cut faster and generate less heat. However, these blades also leave a rougher cut than raker blades.
- **Hook:** The teeth have a positive angle (downward) which makes them dig into the material, and the gullets are usually rounded for easier waste removal. These blades are excellent for the tough demands of resawing and ripping thick material.

## Tooth Pitch

Measured as TPI (teeth per inch), tooth pitch determines the number of teeth. More teeth per inch (fine pitch) will cut slower, but smoother; while fewer teeth per inch (coarse pitch) will cut rougher, but faster. As a general rule, choose blades that will have at least three teeth in the material at all times. Use fine-pitched blades on harder woods and coarse-pitched blades on softer woods.

## Tooth Set

Two common tooth sets for wood bandsaw blades are alternate and raker. Each different type of tooth set removes material in a different manner, leaving cuts with different characteristics (see **Figure 49**).

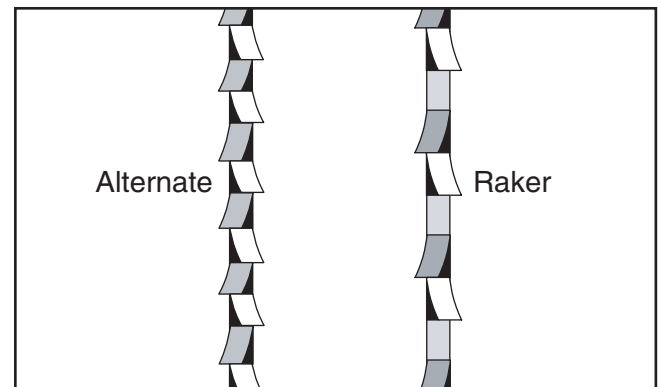

**Figure 49.** Common woodcutting bandsaw blade tooth sets.

- **Alternate:** An all-purpose arrangement where the teeth are bent evenly left and right of the blade.
- **Raker:** Three teeth in a recurring group—one bent left, one bent right, and then one that is not bent. The raker set is ideal for most contour cuts.



## Blade Material

Bandsaw blades must meet two requirements: flexibility and hardness. The flexibility of a blade allows it to travel on the wheel as a band, while hardness allows the teeth to cut and hold an edge. Modern materials technology has allowed bandsaw blades to meet these requirements in various ways.

**Carbon Steel:** These blades are differentially heat treated to provide hard teeth that will hold an edge, and yet be flexible in the back.

**Carbide Tooth:** Extremely hard carbide is either welded onto or impregnated into the carbon steel blades, providing superior edge-holding characteristics (see **Figure 50**).

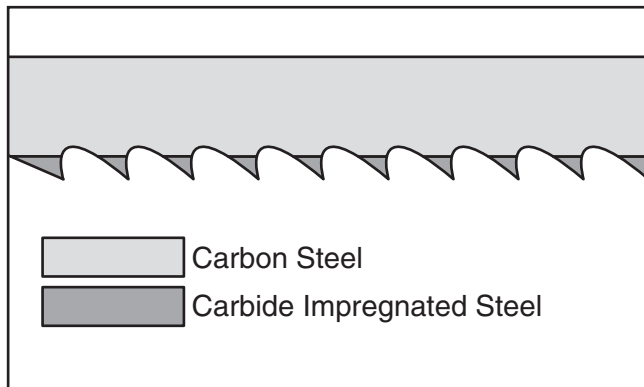

**Figure 50.** Carbide-tooth blade composition.

**Bi-metal Blade:** A strip of high-speed tool steel is precision welded to a flexible carbon blade, then teeth are ground into the blade to provide good edge-holding qualities for blades taking a lot of abuse (see **Figure 51**).

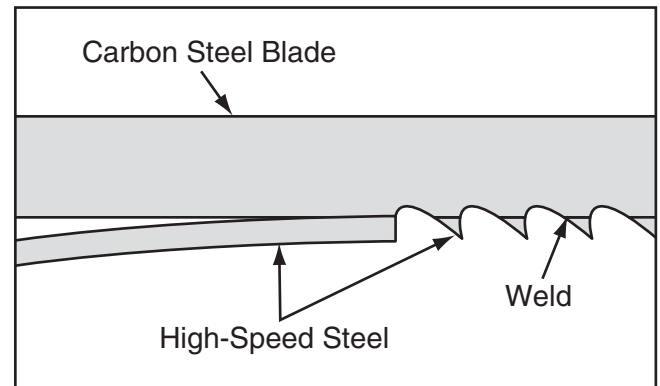







































**Figure 51.** Bi-metal blade composition.



# Blade Selection Chart

Use the blade selection chart below as a general guide when selecting a blade for your operation.

Cutting Operation	Blade Width		
	Narrow ( $\frac{1}{8}$ " - $\frac{1}{4}$ " )	Medium ( $\frac{3}{16}$ " - $\frac{1}{2}$ " )	Wide ( $\frac{1}{2}$ " - $\frac{3}{4}$ " )
Resawing			 
Ripping Thin Stock			 
Ripping Thick Stock			 
Ripping Round Stock		 	 
Crosscutting Thin Stock			 
Crosscutting Thick Stock			 
Crosscutting Round Stock		  	  
Mitre Cut			  
Tenons		 	 
Sharp Curves	 		
Gradual Curves		  	

Key					
Tooth Type			Tooth Pitch (Teeth per Inch or TPI)		
					
Hook	Raker	Skip	Fine (14-32 TPI)	Medium (4-12 TPI)	Coarse (2-4 TPI)



# Blade Breakage

---

Many conditions may cause a bandsaw blade to break. Blade breakage is unavoidable in some cases, since it is the natural result of the peculiar stresses that bandsaw blades must endure.

Blade breakage is also due to avoidable circumstances. Avoidable blade breakage is most often the result of poor care or judgement on the part of the operator when mounting or adjusting the blade or support guides.

## **The most common causes of blade breakage are:**

- Faulty alignment or adjustment of the blade guides.
- Forcing or twisting a wide blade around a short radius.
- Feeding the workpiece too fast.
- Dull or damaged teeth.
- Over-tensioned blade.
- Top blade guide assembly set too high above the workpiece. Adjust the top blade guide assembly so that there is approximately  $\frac{1}{8}$ "– $\frac{1}{4}$ " between the bottom of the assembly and the workpiece.
- Using a blade with a lumpy or improperly finished braze or weld.
- Continuously running the bandsaw when not in use.
- Leaving the blade tensioned when not in use.
- Using the wrong pitch (TPI) for the workpiece thickness. The general rule of thumb is to have not less than two teeth in contact with the workpiece at all times during cutting.

# Blade Care & Break-In

---

## **Blade Care**

A bandsaw blade is a thin piece of steel that is subjected to tremendous strain. You can obtain longer use from a bandsaw blade if you give it fair treatment and always use the appropriate feed rate for your operation.

Be sure to select blades with the proper width, set, type, and pitch for each application. Using the wrong blade will produce unnecessary heat and shorten the life of the blade.

A clean blade will perform much better than a dirty blade. Dirty or gummed up blades pass through the cutting material with much more resistance than clean blades. This extra resistance also causes unnecessary heat.

## **Blade Break-In**

The sharp teeth tips and edges of a new blade are extremely sharp, and cutting at too fast of a feed rate fractures the beveled edges of the teeth and causes premature blade wear.

### **To properly break-in a new blade:**

1. Choose the correct speed for the blade and material of the operation.
2. Reduce the feed pressure by half for the first 50–100 in<sup>2</sup> of material cut.
3. To avoid twisting the blade when cutting, adjust the feed pressure when the total width of the blade is in the cut.



# Changing Blade

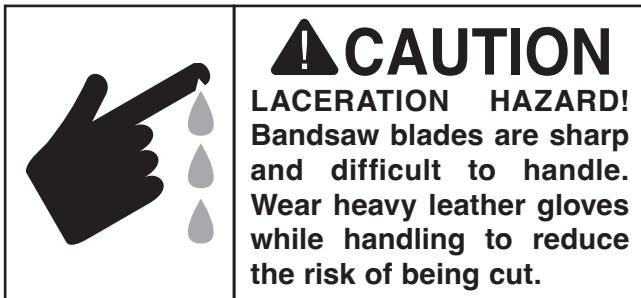
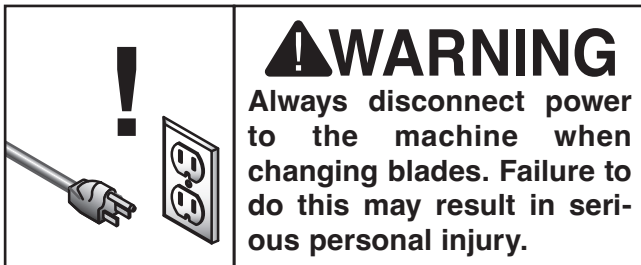

## Removing Blade

1. DISCONNECT MACHINE FROM POWER!
2. Release the blade tension.
3. Remove the table insert and the table pin. Adjust the upper and lower guide bearings as far away as possible from the blade.
4. Open the both wheel covers, and with gloved hands, slide the blade off of both wheels.
5. Slide the blade through the slot in the table.

## Replacing Blade

1. Slide the blade through the table slot, ensuring that the teeth are pointing forward and down toward the table.

**Note:** *If the teeth will not point downward in any orientation, the blade is inside out. Put on heavy gloves, remove the blade, and twist it right side out.*

2. Slip the blade through the guides, and mount it on the upper and lower wheels (see **Figure 52**).

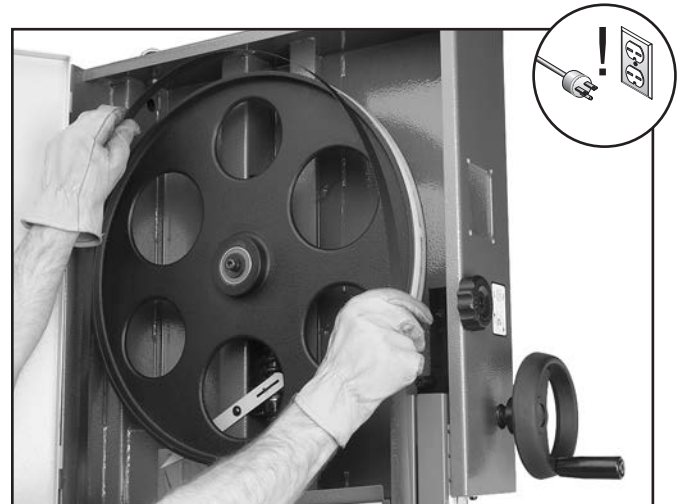

**Figure 52.** Typical example of placing blade on the wheels.

3. Adjust tension as described on **Page 24**.
4. Adjust tracking if needed (see **Page 19**).
5. Align the upper and lower support and guide bearings (see **Page 25**), then adjust the blade guide bearings (see **Page 28**).
6. Replace the table insert and table pin.
7. Close the wheel covers.

## **NOTICE**

When you change the blade or adjust the tension and tracking, the spaces between the guide and support bearings will change. In these cases, you must adjust the upper and lower guide and support bearings before continuing with cutting operations (**Pages 25 & 28**).



# Ripping

Ripping is the process of cutting with the grain of the wood stock. For plywood and other processed wood, ripping simply means cutting down the length of the workpiece. For ripping, a wider blade is better. In most ripping applications, a standard raker tooth style will be sufficient.

## To make a rip cut:

1. Adjust the fence to match the width of the cut on your workpiece and lock the fence in place.
2. Adjust the blade guide assembly to the correct height.
3. After all safety precautions have been met, turn the bandsaw **ON**. Slowly feed the workpiece into the blade and continue with the cut until the blade is completely through the workpiece. **Figure 53** shows a typical ripping operation.

**Note:** *If you are cutting narrow pieces, use a push stick to protect your fingers.*

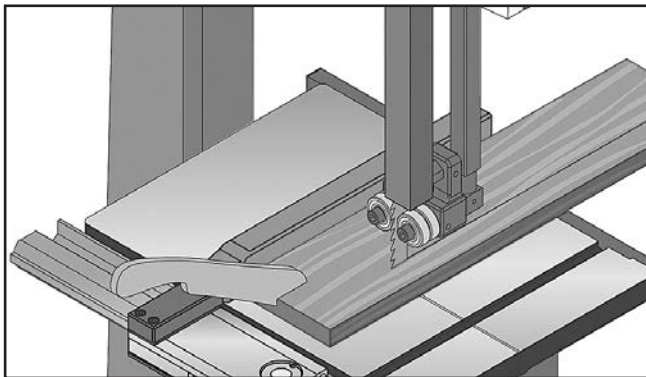

**Figure 53.** Example of typical ripping operation with a push stick.

## **!WARNING**

**NEVER** place fingers or hands in the line of cut. In the event that something unexpected happens, your hands or fingers may slip into the blade. **ALWAYS** use a push stick when ripping narrow pieces. Failure to follow these warnings may result in serious personal injury!

# Crosscutting

Crosscutting is the process of cutting across the grain of wood. For plywood and other processed wood, crosscutting simply means cutting across the width of the material.

## To make a 90° crosscut:

1. Mark the workpiece on the edge where you want to begin the cut.
2. Adjust the blade guide assembly to the correct height and make sure the miter gauge is set to 0° (or other angle for angled cuts).
3. Move the fence out of the way. Place the workpiece evenly against the miter gauge.
4. Hold the workpiece against the miter gauge and line up the mark with the blade.
5. After all safety precautions have been met, turn the bandsaw **ON**. Slowly feed the workpiece into the blade and continue the cut until the blade is all the way through the workpiece. **Figure 54** shows a typical crosscutting operation.

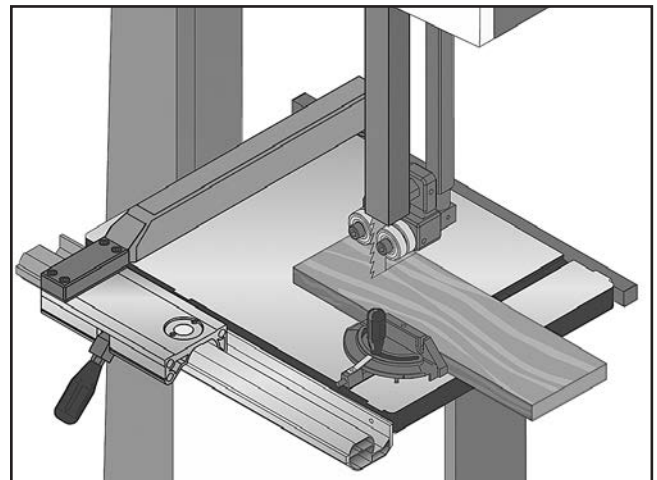

**Figure 54.** Example of crosscutting operation with miter gauge.



# Resawing

"Resawing" (see **Figure 55**) is cutting a workpiece into two or more thinner workpieces. Use the widest blade possible when resawing—a wide blade cuts straighter and is less prone to blade lead (see **Page 58**). For most applications, use a blade with a hook- or skip-tooth style. Choose blades with fewer teeth-per-inch (from 3 to 6), because they offer larger gullet capacities for clearing sawdust, reducing heat buildup and reducing strain on the motor.



**Figure 55.** Example of resawing lumber.

## **⚠️ WARNING**

When resawing thin pieces, a wandering blade (blade lead) can tear through the surface of the workpiece, exposing your hands to the blade teeth. Always use push blocks when resawing and keep your hands clear of the blade.

### To resaw a workpiece:

1. Verify that the bandsaw is set up properly and that the fence is parallel to the blade.
2. Install the resaw fence, set it to the desired width of cut, and lock it in place.
3. Adjust the upper blade guide so it is  $\frac{1}{4}$ "–1" above the workpiece with a minimum amount of blade exposed.

## **NOTICE**

The scale on the front rail will **NOT** be accurate when using the resaw fence.

4. Support the ends of the board if necessary.
5. Turn the bandsaw **ON**.
6. Using push paddles and a push stick, keep pressure against the fence and table, and slowly feed the workpiece into the moving blade until the blade is completely through (see **Figure 55**).



# Cutting Curves

When cutting curves, simultaneously feed and turn the stock carefully so that the blade follows the layout line without twisting. Use either a narrower blade or a blade with more TPI (teeth per inch), or make more relief cuts, to avoid having to back the workpiece away from the blade, especially if the curve is sharp.

Always make short cuts first, then proceed to the longer cuts. Relief cuts will also reduce the chance that the blade will be pinched or twisted. Relief cuts are cuts made through the waste portion of the workpiece and are stopped at the layout line. As you cut along the layout line, waste wood is released from the workpiece, alleviating any pressure on the back of the blade. Relief cuts also make backing the workpiece out easier once the saw blade has come to a stop, if needed.

## NOTICE

The list below displays blade widths and the corresponding minimum radii for those blade widths.

Width	Radius
1/8".....	1/8"
3/16".....	3/8"
1/4".....	5/8"
3/8".....	1 1/4"
1/2".....	2 1/2"
5/8".....	3 3/4"
3/4".....	5 1/2"

# Stacked Cuts

One of the benefits of a bandsaw is its ability to cut multiple copies of a particular shape by stacking a number of workpieces together. Before making stacked cuts, ensure that both the table and the blade are properly adjusted to 90° (Pages 19–20). Otherwise, any error will be compounded.

### To complete a stacked cut:

1. Align your pieces from top to bottom to ensure that each piece has adequate scrap to provide a clean, unhampered cut.
2. Secure all the pieces together in a manner that will not interfere with the cutting. Hot glue on the edges works well, as do brad nails through the waste portion. (Be careful not to cut into the brads or you may break the blade!)
3. On the face of the top piece, lay out the shape you intend to cut.
4. Make relief cuts perpendicular to the outline of your intended shape in areas where changes in blade direction could strain the woodgrain or cause the blade kerf to bind.
5. Cut the stack of pieces as though you were cutting a single piece. Follow your layout line with the blade kerf on the waste side of your line (see Figure 56).

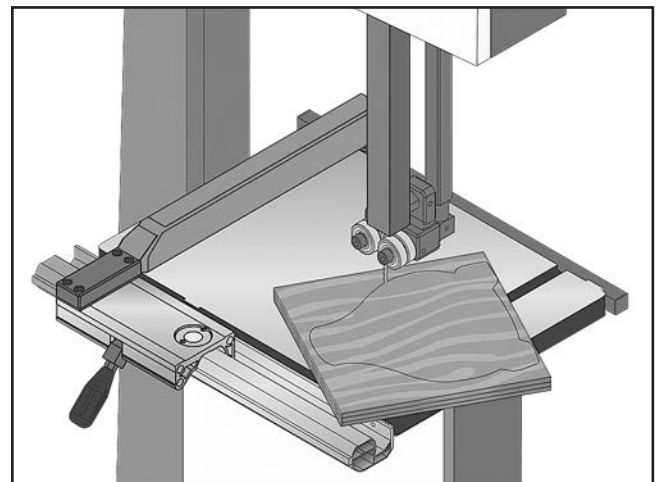

Figure 56. Typical stacked cut.



# SECTION 5: ACCESSORIES

## **! WARNING**

Installing unapproved accessories may cause machine to malfunction, resulting in serious personal injury or machine damage. To reduce this risk, only install accessories recommended for this machine by Grizzly.

## **NOTICE**

Refer to our website or latest catalog for additional recommended accessories.

### 168" Replacement Blades

Model	Width	TPI	Type	Gauge
H9575	1/2"	3	Claw	0.025
H9579	1"	3	Claw	0.035
H9580	1"	4	Claw	0.035
T28377	1"	2-3	Claw	0.035
T33241	1"	1.3	Hook	0.035
T33242	1"	3	Hook	0.035
T32325	2"	1.3	Hook	0.035
T33243	1"	3-4	VP	0.035

### T10456—Heavy-Duty Anti-Fatigue Mat 3' x 5'

This Heavy-Duty Anti-Fatigue Mat features beveled edges and no-slip tread for safety and comfort. Open-hole design allows liquid to drain through, so it's perfect for wet or oily conditions. Measures 3' wide x 5' long x 3/8" thick.

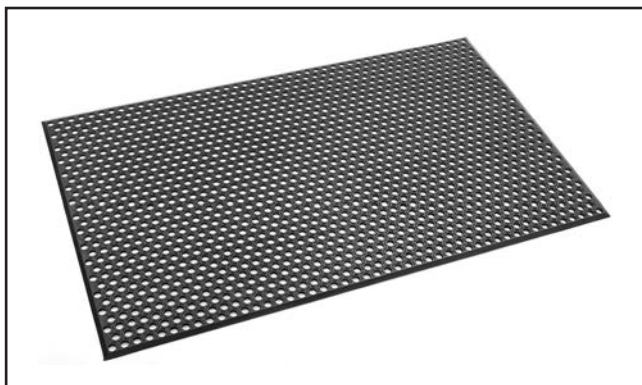

Figure 57. Model T10456 Anti-Fatigue Mat.

### D2058A—Super Heavy-Duty SHOP FOX® Mobile Base

This patented, super heavy-duty mobile machine base is the strongest mobile base on the market. 18 1/2" x 24 1/2" minimum and adjusts to 28 1/2" x 33 1/2". Maximum 1300 lb. capacity. This base is extremely stable with outrigger type supports and a four wheel system. Weighs 39 lbs.



Figure 58. D2058A Shop Fox HD Mobile Base.

### T26403—The Missing Shop Manual: Bandsaw

Dedicated to providing integral information about woodworking tools and techniques that other manuals overlook. In Band Saw, you will find out how to best utilize this essential workshop tool, and how to get the most for your money by getting the most from your equipment. Filled with clear diagrams and instructions, this pocket sized durable manual is ideal for quick reference in the workshop. 112 pages, soft cover.

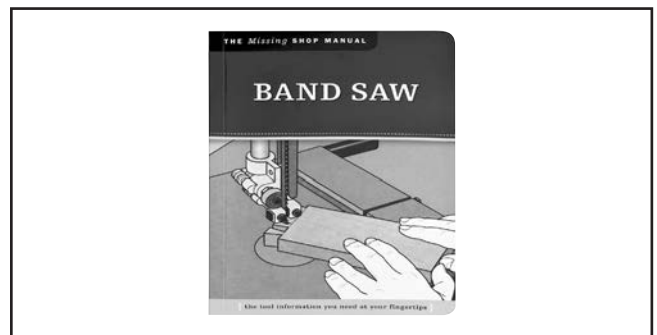

Figure 59. The Missing Shop Manual: Bandsaw.

**order online at [www.grizzly.com](http://www.grizzly.com) or call 1-800-523-4777**



**D2272—Tilting Roller Stand**

Adjusts from 26" to 44", 0°-45°. 150 lb. capacity.

**D2273—Single Roller Stand**

Adjusts from 26 5/8" to 45". 250 lb. capacity.

**D2274—5 Roller Stand**

Adjusts from 26" to 44 5/8". 250 lb. capacity.

These super heavy-duty roller stands feature convenient hand knobs for fast height adjustment.



**Figure 60.** Accessory roller stands.

**Recommended Metal Protectants**

**G5562—SLIPIT® 1 Qt. Gel**

**G5563—SLIPIT® 11 Oz. Spray**



**Figure 61.** Recommended products for protecting unpainted cast iron/steel parts on machinery.

**order online at [www.grizzly.com](http://www.grizzly.com) or call 1-800-523-4777**



# SECTION 6: MAINTENANCE

---

---

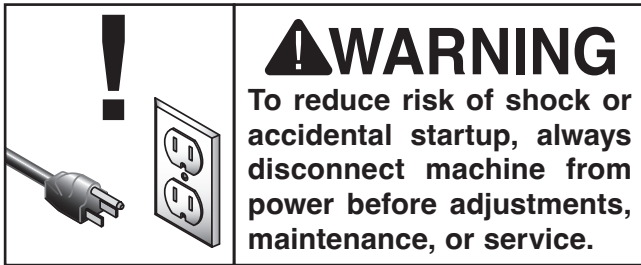

## Schedule

---

---

For optimum performance from this machine, this maintenance schedule must be strictly followed.

### Ongoing

To minimize your risk of injury and maintain proper machine operation, shut down the machine immediately if you ever observe any of the items below, and fix the problem before continuing operations:

- Loose mounting bolts.
- Worn or damaged saw blade.
- Worn or damaged wires.
- Check/clean wheel brushes.
- Clean/protect table surface.
- Check lubrication points.
- Any other unsafe condition.

### Monthly Check:

- V-belt tension, damage, or wear.
- Clean/vacuum dust build-up from inside cabinet and off motor.

## Wheel Brushes

---

---

The bandsaw is equipped with two lower brushes. The brushes should be checked daily and cleaned when they become dirty. There are adjustment brackets that allow the brushes to be adjusted for bristle wear. Refer to **Adjusting Wheel and Blade Brushes** on **Page 59** for adjustment details.

## Cleaning & Protecting

---

---

Cleaning the bandsaw is relatively easy. Vacuum excess wood chips and sawdust, and wipe off the remaining dust with a dry cloth. If any resin has built up, use a resin dissolving cleaner to remove it.

Protect the unpainted cast iron surfaces on the table by wiping it clean after every use—this ensures moisture from wood dust does not remain on bare metal surfaces. Keep the table rust-free with regular applications of products like SLIPIT® (see **Accessories** section for more details).

## Lubrication

---

---

An essential part of lubrication is cleaning the components before lubricating them. This step is critical because dust and chips build up on lubricated components, which makes them hard to move. Simply adding more grease to built-up grime will not result in smooth moving parts. Clean the components in this section with an oil/grease solvent cleaner or mineral spirits before applying lubrication.

All bearings are sealed and permanently lubricated. Leave them alone until they need to be replaced.



## Blade Guide Rack and Pinion

Lubrication Type .....GL2 Grease or Equivalent  
Amount .....Thin Coat  
Frequency..... As Needed

### To lubricate the blade guide rack and pinion:

1. Lower the upper blade guide until it reaches the table.
2. DISCONNECT MACHINE FROM POWER!
3. Using a rag and mineral spirits, wipe off any existing grease and sawdust buildup on the rack (see **Figure 62**).

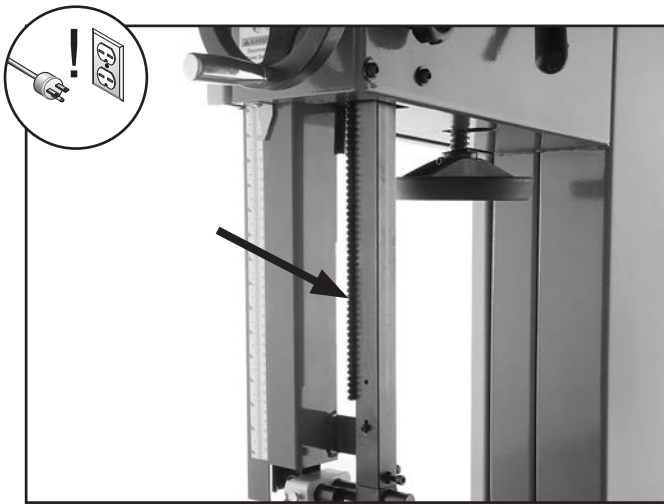

**Figure 62.** Example of rack lubrication location.

4. Apply a thin coat of multi-purpose GL2 grease to the rack.
5. Re-connect the machine to power, then move the blade guide up and down several times to distribute the lubricant.
6. Lower the blade guide to the table, disconnect the bandsaw from power, then remove any excess grease from the rack to help prevent sawdust buildup.

## Tension Adjustment Assembly

Lubrication Type .....GL2 Grease or Equivalent  
Amount .....Thin Coat  
Frequency..... As Needed

### To lubricate the tension adjustment assembly:

1. DISCONNECT MACHINE FROM POWER!
2. Open the top wheel cover and look through the top of the wheel.
3. Using a rag and mineral spirits, wipe off any existing grease and sawdust buildup on the blade tension adjustment assembly and tension lever cam.
4. Apply a thin coat of multi-purpose GL2 grease to the tension adjustment assembly and tension lever cam (see **Figure 63**).

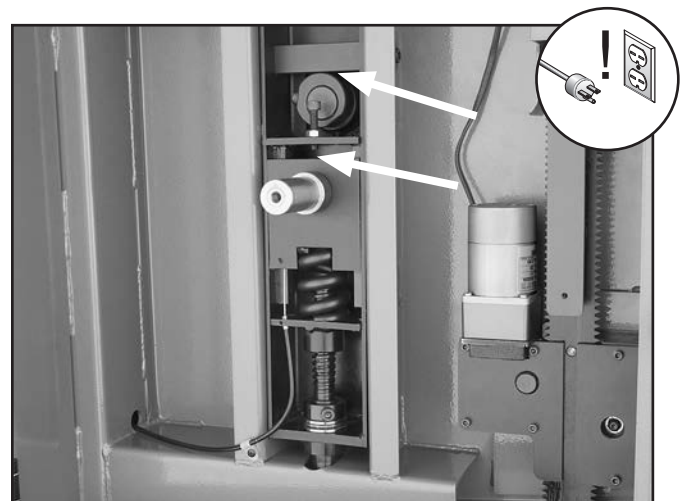

**Figure 63.** Tension adjustment assembly locations (top wheel removed for clarity).



## Table Tilt Rack and Pinion Assembly

Lubrication Type .....GL2 Grease or Equivalent  
Amount .....Thin Coat  
Frequency..... As Needed

### To lubricate the table tilt rack and pinion assembly:

1. DISCONNECT MACHINE FROM POWER!
2. With the table perpendicular to the blade, and using a rag and mineral spirits, wipe off all existing grease and sawdust buildup from the rack.
3. Move the table up to its maximum 45° angle and wipe off all existing grease and sawdust buildup from the rack (see **Figure 64**).



**Figure 64.** Lubricating table tilt rack and pinion assembly.

4. Apply a thin coat of multi-purpose GL2 grease to the rack.
5. Move the table up and down several times to distribute the grease, then wipe off any excess grease.

## Trunnion

Lubrication Type .....GL2 Grease or Equivalent  
Amount .....Thin Coat  
Frequency..... As Needed

### To lubricate the trunnion:

1. DISCONNECT MACHINE FROM POWER!
2. Move the table up until it reaches its maximum 45° angle, then use a rag and mineral spirits to wipe off all excess grease and sawdust from the trunnion.
3. Apply a thin coat of multi-purpose GL2 grease to the outside surfaces of the trunnion (see **Figure 65**).

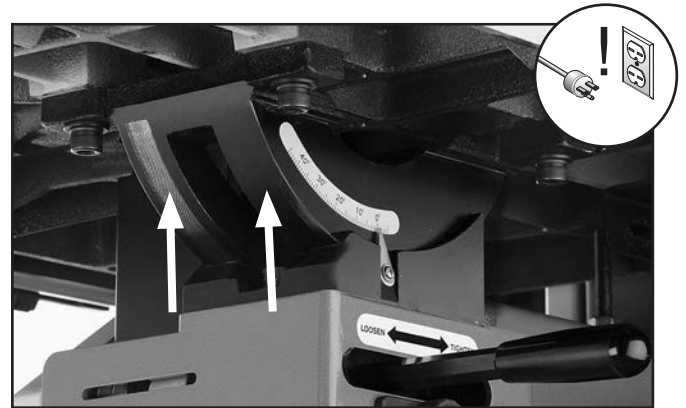

**Figure 65.** Trunnion lubrication location.

4. Move the table down and then back up to distribute the grease, then wipe off any excess grease from the trunnion.



# Redressing Rubber Tires

---

---

As the bandsaw ages, the rubber tires may need to be redressed if they become hardened or glazed. Redressing the rubber tires improves blade tracking and reduces vibration/blade lead.

If the rubber tires become too worn, then blade tracking will become extremely difficult. At that point, redressing will no longer be effective and the tires must be replaced.

## To redress the rubber tires:

1. DISCONNECT MACHINE FROM POWER!
2. Put on heavy leather gloves.
3. Remove the blade.
4. Clean any built-up sawdust from the rubber tires.
5. Hold 100-grit sandpaper against the rubber tire and rotate the wheel by hand. Only redress the rubber enough to expose a fresh rubber surface.
6. Re-install the blade, then check blade tension (refer to **Page 24**) and tracking (refer to **Page 19**).



# SECTION 7: SERVICE

Review the troubleshooting procedures in this section if a problem develops with your machine. If you need replacement parts or additional help with a procedure, call our Technical Support. **Note:** *Please gather the serial number and manufacture date of your machine before calling.*

## Troubleshooting



### Motor & Electrical

Symptom	Possible Cause	Possible Solution
Machine does not start or a breaker trips.	<ol style="list-style-type: none"> <li>1. Emergency OFF button engaged/at fault.</li> <li>2. Key switch turned to "0" position.</li> <li>3. Upper wheel cover safety switch disengaged/at fault.</li> <li>4. Brake switch at fault.</li> <li>5. Thermal overload relay in mag switch tripped.</li> <li>6. Break or short in wiring; or loose or corroded connections.</li> <li>7. Plug or receptacle is corroded or mis-wired.</li> <li>8. Power supply switched off/has incorrect voltage.</li> <li>9. Motor connection wired incorrectly.</li> <li>10. Contactor has poor contacts or is at fault.</li> <li>11. Blown fuse/tripped circuit breaker.</li> <li>12. Motor ON switch at fault.</li> <li>13. Start capacitor has blown.</li> <li>14. Centrifugal switch at fault.</li> <li>15. Motor at fault.</li> </ol>	<ol style="list-style-type: none"> <li>1. Rotate button to reset/replace button.</li> <li>2. Turn key switch to "1" position.</li> <li>3. Close upper wheel cover or adjust/test/replace switch.</li> <li>4. Re-adjust/test/replace brake switch.</li> <li>5. Allow relay/motor to cool. If necessary, press reset button inside switch.</li> <li>6. Trace/replace broken or corroded wires; fix loose connections.</li> <li>7. Correct the wiring.</li> <li>8. Switch power supply on/verify voltage.</li> <li>9. Wire motor correctly. Refer to inside junction box cover on <b>Page 69</b>.</li> <li>10. Test all legs for power, test field coil, and fix contacts or replace if at fault.</li> <li>11. Replace/reset fuse or circuit breaker. Repair possible short or circuit overload.</li> <li>12. Replace switch.</li> <li>13. Test/replace if at fault.</li> <li>14. Adjust/replace centrifugal switch.</li> <li>15. Test for shorted windings or bad bearings; repair or replace.</li> </ol>
Main motor chatters during startup or during operation.	<ol style="list-style-type: none"> <li>1. Power supply has incorrect voltage on one or more legs.</li> </ol>	<ol style="list-style-type: none"> <li>1. Contact electrician to check incoming voltage.</li> </ol>



## Motor & Electrical (Cont.)

Symptom	Possible Cause	Possible Solution
Machine has excessive vibration or noise.	<ol style="list-style-type: none"> <li>1. V-belt tension incorrect.</li> <li>2. Bent, dull, or damaged blade.</li> <li>3. Loose blade.</li> <li>4. Blade weld contacting support bearing or blade guides.</li> <li>5. Loose machine component.</li> <li>6. Machine incorrectly mounted on floor.</li> <li>7. Motor fan rubbing on fan cover.</li> <li>8. V-belt worn or damaged.</li> <li>9. Wheels not coplanar.</li> <li>10. V-belt has a high spot.</li> <li>11. Centrifugal switch out of adjustment; at fault.</li> <li>12. Pulley loose or not in alignment; shaft bent.</li> <li>13. Worn wheel bearing.</li> <li>14. Wheel tires worn or incorrectly installed.</li> <li>15. Wheels out of balance.</li> <li>16. Motor bearings worn or damaged.</li> </ol>	<ol style="list-style-type: none"> <li>1. Tighten V-belt (<b>Page 56</b>).</li> <li>2. Replace blade (<b>Page 42</b>).</li> <li>3. Tighten blade.</li> <li>4. Use file or stone to smooth and round the back of the blade.</li> <li>5. Tighten loose component.</li> <li>6. Level/shim base; tighten/adjust mounting hardware or feet.</li> <li>7. Fix/replace fan cover; replace loose or damaged fan.</li> <li>8. Replace V-belt (<b>Page 57</b>).</li> <li>9. Adjust wheels to be coplanar (<b>Page 64</b>).</li> <li>10. Replace/adjust the V-belt (<b>Page 57</b>).</li> <li>11. Adjust/replace centrifugal switch.</li> <li>12. Replace worn pulley, key, and shaft, and realign.</li> <li>13. Check/replace wheel bearing.</li> <li>14. Replace or re-install wheels.</li> <li>15. Replace wheels.</li> <li>16. Replace motor bearings or replace motor.</li> </ol>

## Operations

Symptom	Possible Cause	Possible Solution
Machine stalls or slows when operating.	<ol style="list-style-type: none"> <li>1. Too much pressure when feeding workpiece.</li> <li>2. Workpiece too moist or material not suitable for machine.</li> <li>3. Workpiece is warped.</li> <li>4. Fence incorrectly adjusted.</li> <li>5. V-Belt(s) slipping.</li> <li>6. Run capacitor at fault.</li> <li>7. Motor connection wired incorrectly.</li> <li>8. Motor overheated.</li> <li>9. Contactor has poor contacts or is at fault.</li> <li>10. Centrifugal switch at fault.</li> <li>11. Main motor at fault.</li> </ol>	<ol style="list-style-type: none"> <li>1. Reduce pressure when feeding workpiece.</li> <li>2. Only cut wood and ensure workpiece moisture is below 20%.</li> <li>3. Straighten workpiece or use a different one.</li> <li>4. Adjust/calibrate fence.</li> <li>5. Tension/replace belt (<b>Page 56</b>); ensure pulleys are aligned (<b>Page 64</b>).</li> <li>6. Test/repair/replace.</li> <li>7. Review wiring diagram on motor cover; correct wire connections.</li> <li>8. Let cool, clean motor, and reduce workload.</li> <li>9. Test all legs for power, test field coil, and fix contacts or replace if at fault.</li> <li>10. Adjust/replace centrifugal switch if available.</li> <li>11. Test for shorted windings, bad bearings and repair or replace.</li> </ol>
Guide post moves slower than normal, travel is sporadic, or stops completely.	<ol style="list-style-type: none"> <li>1. Guide post motor at fault.</li> </ol>	<ol style="list-style-type: none"> <li>1. Replace guide post motor (<b>Page 62</b>).</li> </ol>
Miter bar binds in miter slot.	<ol style="list-style-type: none"> <li>1. Miter slot dirty or gummed up.</li> </ol>	<ol style="list-style-type: none"> <li>1. Carefully clean miter slot with mineral spirits.</li> </ol>
Table does not tilt to 0 degrees.	<ol style="list-style-type: none"> <li>1. Pointer or scale calibrated incorrectly.</li> <li>2. Positive stop bolt not set correctly.</li> </ol>	<ol style="list-style-type: none"> <li>1. Calibrate pointer/scale at true 0 degrees (<b>Page 32</b>).</li> <li>2. Adjust positive stop bolt (<b>Page 20</b>).</li> </ol>



Symptom	Possible Cause	Possible Solution
Table does not tilt to 45 degrees.	<ol style="list-style-type: none"> <li>1. Pointer or scale calibrated incorrectly.</li> <li>2. Machine component blocking path.</li> </ol>	<ol style="list-style-type: none"> <li>1. Calibrate pointer/scale at true 45 degrees.</li> <li>2. Inspect/remove component blocking table.</li> </ol>
Table hard to tilt.	<ol style="list-style-type: none"> <li>1. Sawdust or pitch trapped between trunnion and base.</li> <li>2. Metal burrs on trunnion.</li> </ol>	<ol style="list-style-type: none"> <li>1. Clean trunnion.</li> <li>2. Remove burrs.</li> </ol>
The cuts are rough, or show scoring.	<ol style="list-style-type: none"> <li>1. Blade is overloaded and twisting.</li> <li>2. The blade TPI is too coarse.</li> <li>3. The blade is loose and slipping on wheels.</li> <li>4. Blade tracking is incorrect.</li> <li>5. The blade has missing or bent teeth.</li> <li>6. The blade has a faulty weld.</li> </ol>	<ol style="list-style-type: none"> <li>1. Decrease the feed rate.</li> <li>2. Use the correct blade for material and speed of cut.</li> <li>3. Adjust bade tension as required.</li> <li>4. Adjust the blade tracking back to normal.</li> <li>5. Inspect/replace blade (<b>Page 42</b>).</li> <li>6. Inspect/replace blade (<b>Page 42</b>).</li> </ol>
Blade or teeth break.	<ol style="list-style-type: none"> <li>1. Blade tension is incorrect.</li> <li>2. Incorrect blade for application.</li> <li>3. The feed rate is too fast.</li> <li>4. Cutting corners too sharply.</li> <li>5. Blade used when dull.</li> <li>6. Blade tracking is wrong.</li> <li>7. Blade guide adjustment at fault.</li> <li>8. Inadequate blade support.</li> <li>9. Blade weld at fault.</li> <li>10. Wheel tires worn or incorrectly installed.</li> <li>11. Fence or miter slot out of alignment with blade.</li> </ol>	<ol style="list-style-type: none"> <li>1. Adjust blade tension (<b>Page 24</b>).</li> <li>2. Use correct blade for application.</li> <li>3. Reduce feed rate.</li> <li>4. Use a wider arc on outside cuts, or use relief cuts to make tight inside cuts.</li> <li>5. Inspect/replace blade (<b>Page 42</b>).</li> <li>6. Adjust blade tracking (<b>Page 19</b>).</li> <li>7. Adjust blade guide bearings for correct blade support.</li> <li>8. Adjust upper blade guides as close as possible to workpiece.</li> <li>9. Inspect/replace blade (<b>Page 42</b>).</li> <li>10. Replace or re-install wheels.</li> <li>11. Align table miter slot and fence with blade (<b>Page 30</b>).</li> </ol>
Blade wears on one side, slows, smokes or shows overheating.	<ol style="list-style-type: none"> <li>1. Blade contacting table insert.</li> <li>2. The blade guides are worn or mis-adjusted.</li> <li>3. The blade has insufficient support.</li> <li>4. Blade is installed backwards.</li> <li>5. Too much side pressure when feeding workpiece.</li> <li>6. The wheels are out of alignment.</li> <li>7. Dull or incorrect blade.</li> <li>8. Blade is deformed.</li> <li>9. Fence not parallel with blade (pressure at blade backside).</li> <li>10. Table top surface is not parallel or square to blade.</li> </ol>	<ol style="list-style-type: none"> <li>1. Adjust blade guide bearings to eliminate excess side pressure. Adjust table for correct blade clearance and miter slot alignment.</li> <li>2. Adjust or replace the blade guides.</li> <li>3. Adjust the blade guide support bearings correctly.</li> <li>4. Check blade direction as described in "Replacing Blade" on <b>Page 42</b> and reverse blade if necessary.</li> <li>5. Feed workpiece straight into the blade.</li> <li>6. Adjust the wheels so they are coplanar (<b>Page 64</b>).</li> <li>7. Inspect/replace blade (<b>Page 42</b>).</li> <li>8. Install new blade.</li> <li>9. Adjust fence parallel with blade (<b>Page 30</b>).</li> <li>10. Adjust/shim table/trunnion position until blade and table are parallel and square.</li> </ol>
Sawdust buildup inside cabinet.	<ol style="list-style-type: none"> <li>1. Clogged dust port.</li> <li>2. Low CFM (airflow) from dust collection system.</li> </ol>	<ol style="list-style-type: none"> <li>1. Clean out dust port.</li> <li>2. Repair ducting for leaks or clogs, move dust collector closer to machine, install a stronger dust collector.</li> </ol>



Symptom	Possible Cause	Possible Solution
Blade tracks incorrectly, or comes off wheels.	<ol style="list-style-type: none"> <li>1. Tracking is not adjusted properly.</li> <li>2. Wheels are not coplanar.</li> <li>3. Blade tension is too loose.</li> <li>4. Blade guides need adjustment.</li> <li>5. Feeding workpiece too fast.</li> <li>6. Incorrect blade for bandsaw.</li> <li>7. Blade is deformed, worn or dull.</li> <li>8. Rubber tire on wheel is damaged or worn.</li> </ol>	<ol style="list-style-type: none"> <li>1. Adjust tracking (<b>Page 19</b>).</li> <li>2. Adjust wheel coplanarity (<b>Page 64</b>).</li> <li>3. Increase blade tension (<b>Page 24</b>).</li> <li>4. Align and adjust blade guides (<b>Pages 25-28</b>).</li> <li>5. Feed workpiece slower.</li> <li>6. Install correct blade for machine.</li> <li>7. Install new blade, and de-tension blade when not in use.</li> <li>8. Replace wheels.</li> </ol>
The cut is crooked, or the blade wanders (blade lead).	<ol style="list-style-type: none"> <li>1. The feed pressure is too high or the blade speed is too slow.</li> <li>2. The blade tension is low.</li> <li>3. The blade is dull or damaged.</li> <li>4. Inadequate blade support.</li> <li>5. Incorrect blade for application.</li> <li>6. The blade tracking is wrong.</li> <li>7. Table is loose.</li> <li>8. Fence or miter slot out of alignment with blade.</li> <li>9. Blade guide alignment at fault.</li> </ol>	<ol style="list-style-type: none"> <li>1. Adjust feed rate and cutting speed as required.</li> <li>2. Increase the blade tension (<b>Page 24</b>).</li> <li>3. Inspect/replace blade (<b>Page 42</b>).</li> <li>4. Adjust upper blade guide so it is as close as possible to workpiece (<b>Page 28</b>).</li> <li>5. Use wider blade.</li> <li>6. Adjust the blade tracking back to normal.</li> <li>7. Tighten table trunnion mounting bolts or tilt lock lever.</li> <li>8. Align table miter slot and fence with blade.</li> <li>9. Adjust blade guide bearings for correct blade support.</li> </ol>



# Checking & Tensioning V-Belts

To ensure optimum power transmission from the motor to the blade, the V-belts must be in good condition and operate under proper tension. The belts should be checked for cracks, fraying, and wear. Belt tension should be checked at least every 3 months—more often if the bandsaw is used daily.

Tools Needed:	Qty
Ruler .....	1
Hex Wrench 6mm.....	1
Wrench 17mm .....	1
2x4s 14" .....	2

## Checking V-Belts

1. DISCONNECT MACHINE FROM POWER!
2. Open the wheel covers.
3. Note the condition of the V-belts. If the V-belts are cracked, frayed, or glazed, they should be replaced.
4. Push the center of the V-belts. Note the amount of deflection (see **Figure 66**). If deflection is more than  $\frac{1}{8}$ ", tension the V-belt.

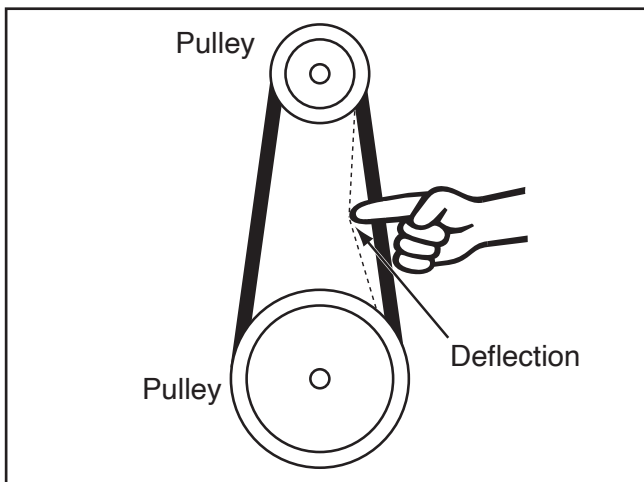

**Figure 66.** V-belt deflection.

## Tensioning V-Belts

1. DISCONNECT MACHINE FROM POWER!
2. Open the wheel covers.
3. Loosen the motor adjustment screws shown in **Figure 67**.

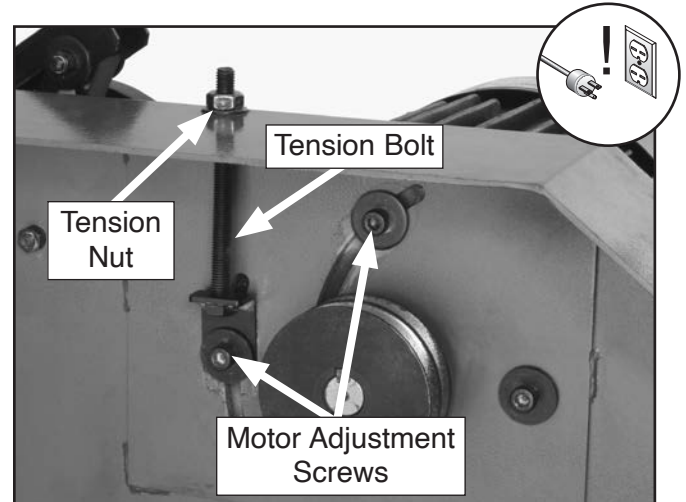

**Figure 67.** Motor mount bolts and tension bolt (lower wheel removed for clarity).

4. Adjust the V-belt tension:
    - If the belt is too loose, turn the tension nut clockwise to tighten the belts.
    - If the V-belt is too tight, turn the tension nut counterclockwise to loosen the belts.
- Note:** The V-belt tension is correct when there is approximately  $\frac{1}{8}$ " deflection between the pulleys when moderate pressure is applied with your hand.
6. When the V-belt tension is correct, tighten the motor adjustment screws, and close the wheel covers.



## Replacing V-Belts

1. Follow **Steps 1-3** in **Checking V-Belts** on **Page 56**.
2. Open the wheel covers, then remove the bandsaw blade (refer to **Changing Blade** on **Page 42**).
3. Loosen the motor adjustment screws shown in **Figure 67** on **Page 56**, then turn the tension nut counterclockwise.
4. Roll the old V-belts off of the motor pulley.
5. Remove the wheel cap screw and flat washer shown in **Figure 68**, then slide the lower wheel out and set it on a flat surface.



**Figure 68.** Wheel cap screw for removing the wheel.

6. Remove the old V-belts from the lower wheel pulley.
7. Inspect the brake shoe.
  - If the brake pad thickness measures 1mm or less, then it needs to be replaced. Follow the instructions in **Replacing Brake Shoe** on **Page 63** to replace it.

8. Place the new V-belts onto the lower wheel pulley.
9. Slide the wheel all the way towards the back of the machine, then secure it with the cap screw and flat washer removed in **Step 5**.

### **⚠ CAUTION**

**In the next step you must be extremely careful while rolling the belts onto the pulley. Your fingers could be pinched between the pulley and belts if you are not careful.**

10. Roll the new V-belts onto the motor pulley.

*Note: Replace both V-belts as a matched set.*

11. Tension the V-belts (see **Tensioning V-Belts** on **Page 56**), then tighten the motor adjustment screws.
12. Re-install the blade, adjust blade tension (refer to **Page 24**) and tracking (refer to **Page 19**), then close the wheel covers.



# Blade Lead

Bandsaw blades may wander off the cut line when sawing, as shown in **Figure 69**. This is called blade lead. Blade lead is usually caused by too fast of a feed rate, a dull or abused blade, or improper tension. If your blade is sharp/undamaged and you still have blade lead, perform the following procedures.



**Figure 69.** Example of blade leading away from line of cut.

## Correcting Blade Lead

1. Use less pressure when feeding the workpiece through the cut.
2. Check that the miter slot and fence are parallel to the blade line, and correct if necessary (See **Aligning Table, Page 29** and **Aligning Fence, Page 30**).
3. Check for proper blade tension. If the blade tension is correct and it is not convenient to replace the blade, compensate for lead by skewing the fence or shifting the table.

### To skew your fence:

1. Cut a piece of scrap wood approximately  $\frac{3}{4}$ " thick x 3" wide x 17" long. On a wide face of the board, draw a straight line parallel to the long edge.

2. Slide the bandsaw fence out of the way and cut halfway through the board on the line by pushing it into the blade. Turn the bandsaw **OFF** and wait for the blade to stop.
3. Clamp the board to the bandsaw table without moving it. Now slide the fence over to the board so it barely touches one end of the board.
4. Loosen the three cap screws that secure the fence rail to the underside of the table (see **Page 31**).
5. Skew the fence so it is parallel to the edge of the scrap piece.
6. While maintaining the skew, tighten the cap screws loosened in **Step 4**.
7. Make a few cuts using the fence. If the fence still does not seem parallel to the blade, repeat **Steps 1–6** until the blade and fence are parallel with each other.

### To shift the table:

1. On a scrap piece of wood, mark a line that is perpendicular to the front edge.
2. Cut halfway through the board on the line by pushing it into the blade.
3. Turn the bandsaw **OFF** and wait for the blade to stop.
4. Loosen the four cap screws that mount the table to the trunnion. Shift the table to compensate for the blade lead, then retighten the cap screws.
5. Repeat **Steps 1–4** until the blade cuts straight.



# Adjusting Wheel & Blade Brushes

The lower wheel compartment contains the brushes shown in **Figure 70**. These brushes are designed to sweep sawdust off the wheel tire and blade as the bandsaw is operating. To work properly, the brushes must make contact with the wheel and blade.

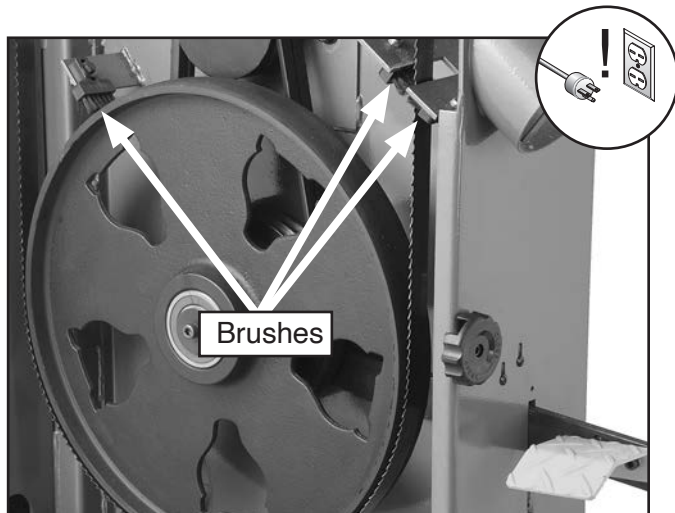

**Figure 70.** The wheel brush and blade brushes.

Tools Needed:	Qty
Wrench/Socket 10mm .....	2

## To adjust the brushes:

1. DISCONNECT MACHINE FROM POWER!
2. Open the upper and lower wheel covers.
3. Loosen the bolt/nut that secures each brush in place.
4. Adjust each brush so it makes good contact with the wheel or blade—without bending the bristles.
5. Tighten the bolt/nuts to secure each brush in place.

# Adjusting Tension Lever

The quick release tension lever is set up correctly for use with the pre-installed 168" blade. However, if you install a different length blade, you will need to adjust the tension lever adjustment screw so the quick release tension lever works correctly.

Tools Needed:	Qty
Hex Wrench 6mm.....	1
Wrench 13mm .....	2

## To adjust the tension lever:

1. DISCONNECT MACHINE FROM POWER!
2. Open the wheel covers.
3. Loosen the jam nut (see **Figure 71**), then remove the screw and nut.

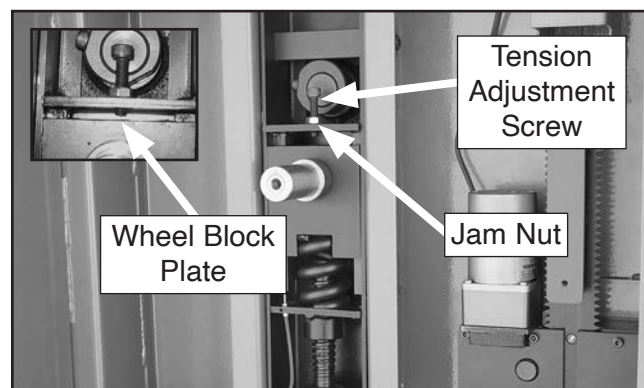

**Figure 71.** Quick release tension lever adjustment screw.

4. Put the quick release tension lever in the engaged position (all the way to the right), then turn the blade tension handwheel until the blade tension matches the mark on the blade tension scale for the appropriate blade width.
5. Thread the cap screw with the jam nut through the plate where it was attached previously and down until it contacts the wheel block plate, then back the screw off two full turns (see **Figure 71**).
6. Tighten the jam nut.



# Adjusting Guide Post Travel

The guide post assembly should remain parallel with the blade front-to-back and side-to-side along its length of travel. If it does not, follow these instructions to correctly adjust the guide post.

## Tools Needed:

Machinist's Square .....	1
Small Ruler .....	1
Hex Wrench 5mm.....	1
Hex Wrench 6mm.....	1
Wrench 10mm .....	1
Metal Shims.....	(As Needed)

## Checking/Adjusting Guide Post Parallel Side-to-Side With Blade

1. Loosen the guide post lock knob, raise the guide post and lock it in place.
2. DISCONNECT MACHINE FROM POWER!
3. Tighten the blade to the tension that will be used during operation.
4. Place a machinist's square on the table next to the side of the blade as illustrated in **Figure 72**.

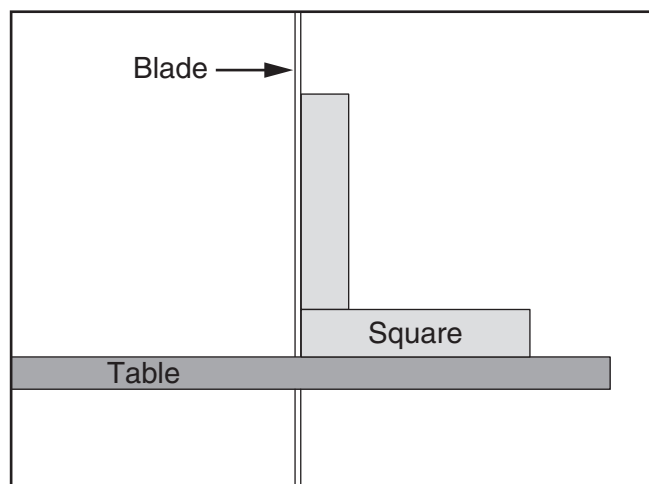

**Figure 72.** Squaring table to blade.

5. Adjust the table square to the blade using the table tilt handwheel, then secure it with the table tilt lock handle.

6. Re-connect the machine to power, and lower the guide post to within 1" of the table top, tighten the guide post lock knob to hold it in place.
7. Disconnect the machine from power, then place a machinist's square on the table next to the right hand side of the guide post, as shown in **Figure 73**.

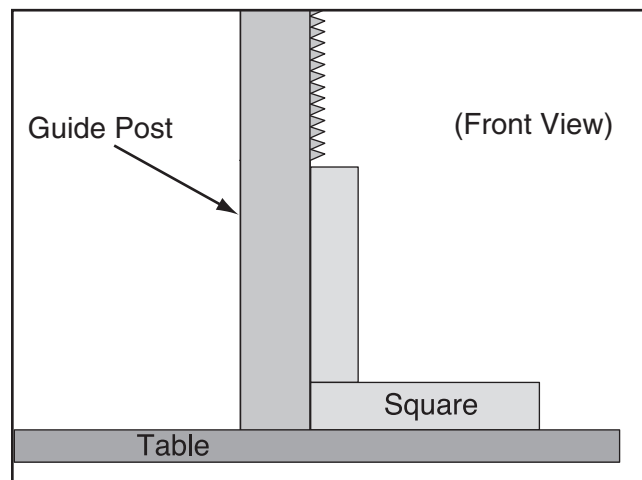
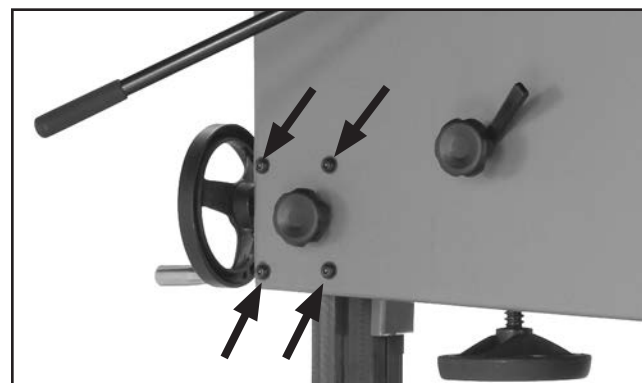

**Figure 73.** Example of checking guide post squareness.

—If there is no gap between the square and the guide post along its full length, no adjustments need to be made. Proceed to "To check/adjust if the guide post is parallel with the blade front-to-back."

—If there is a gap between the square and the guide post, the guide post is not parallel with the blade. Go to **Step 8**.

8. Loosen each of the four screws shown in **Figure 74** ¼ turn.



**Figure 74.** Guide post adjustment screws.



9. Gently tap the lower part of the guide post in the appropriate direction until there is no gap between the square and the guide post.
10. Tighten the screws shown in **Figure 74**, and verify that the guide post stays parallel with the blade along its full path of movement. If necessary, repeat **Steps 8–10** until it is.

### Checking/Adjusting Guide Post Parallel with Blade Front-to-Back

1. DISCONNECT MACHINE FROM POWER!
2. Remove the blade.
3. Place one hand under the upper blade guide assembly to keep it from falling, loosen the two cap screws that secure the guide assembly to the guide post (see **Figure 75**), then remove the guide assembly.

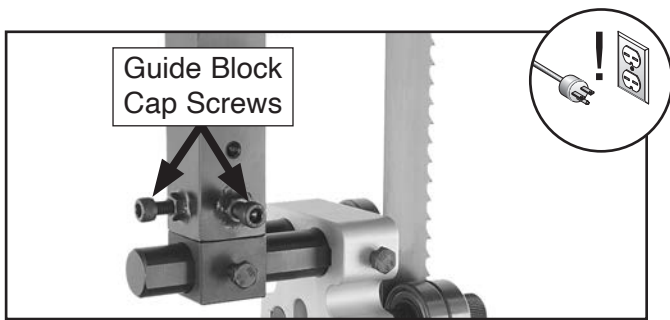

**Figure 75.** Guide block cap screws (blade guard removed for photo clarity).

4. Remove the two cap screws and hex bolt that secure the upper blade guard to the guide post, then remove the blade guard.
5. Re-install the blade and re-tension it.
6. Loosen the guide post lock knob, lower the guide post to within 1" of the table top, then tighten the lock knob.

7. Measure the distance "A" between the top front face of the guide post rack and the back of the blade (see **Figure 76**).
8. Measure the distance "B" between the bottom front face of the guide post rack and the back of the blade (see **Figure 76**).

—If the measurements taken in **Steps 7–8** are equal, no adjustments need to be made. Go to **Step 11**.

—If the measurements taken in **Steps 7–8** are not equal, go to **Step 9**.

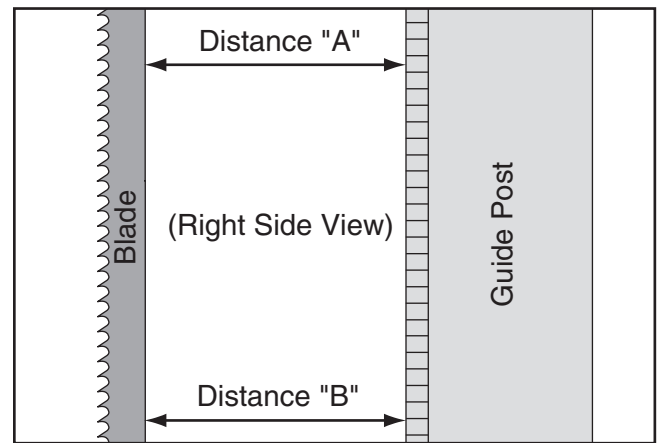

**Figure 76.** Example of measuring distance between rack and blade at top of guide post.

9. Loosen the four screws shown in **Figure 74** enough to fit metal shims (wide enough to fit the full width of the guide bracket), between the frame and the guide post bracket (see **Figure 77**).

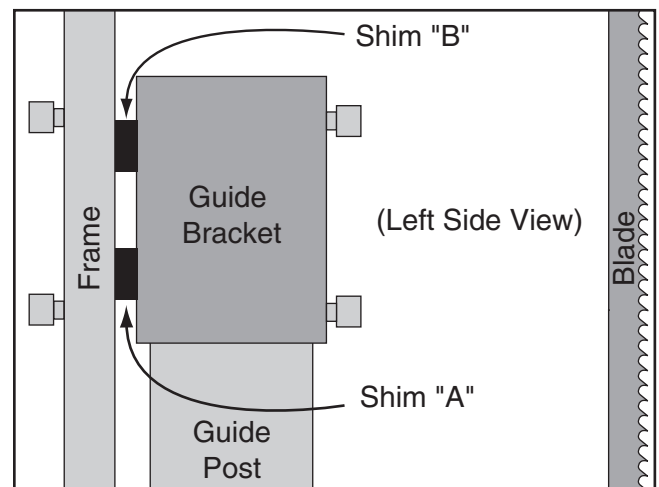

**Figure 77.** Location for placing shims. (Shim thickness not drawn to scale.)



—If the guide post-to-blade distance is greater at the bottom than at the top, place a shim between the bottom of the bracket and the frame (Shim "A"). This will tilt the bottom of the guide post toward the blade.

—If the guide post-to-blade distance is less at the bottom than at the top, place a shim between the top of the bracket and the frame (Shim "B"). This will tilt the bottom of the guide post away from the blade.

10. Tighten the four screws shown in **Figure 74**, then repeat **Steps 7–8**.

11. Remove the blade.

12. Re-install the blade guard with the two cap screws and hex bolt you removed in **Step 4**.

**Tip:** *It may help to install the lower part of the guard first with the cap screws, then install the hex bolt. Also, when the guide post assembly is raised up there is limited room to access the hole where the hex bolt threads in. So, try installing the hex bolt with the guide post assembly closer to the table.*

13. Re-install the blade guide assembly.

14. Re-install the blade and the table pin, then close the wheel covers.

15. Check the blade tension (refer to **Page 24**) and tracking (refer to **Page 19**).

16. Perform the **Aligning Blade Bearings** and **Adjusting Blade Guide Bearings** procedures on **Pages 25** and **28**.

# Replacing Guide Post Motor

If the guide post motor ever needs to be replaced, contact our Technical Support Department at (570) 546-9663 to order the replacement guide post motor (refer to **Page 80**).

Tools Needed	Qty
Phillips Head Screwdriver.....	1

## To replace the guide post motor:

1. DISCONNECT MACHINE FROM POWER!
2. Remove the blade guard from the guide post.
3. Remove the blade and upper wheel.
4. Remove the Phillips head screws that secure the motor to the gear box (see **Figure 78**).

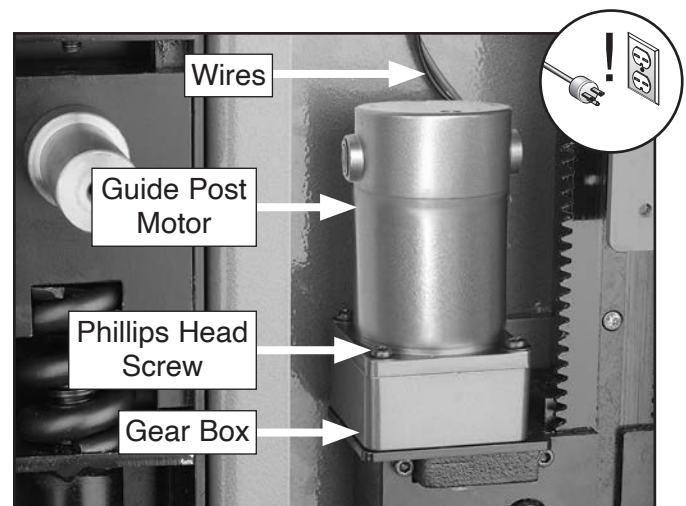

**Figure 78.** Location of guide post motor.

5. Disconnect the guide post motor wires from the wires inside the upper frame, making sure you secure these to the bandsaw temporarily so they do not drop into the frame.



6. Mount the new motor to the gearbox with the screws you removed in **Step 3**, then connect the new guide post motor wires to the wires inside the frame.
7. Replace the upper wheel.
8. Re-install the upper blade guard.
9. Re-install, tension, and track the blade.

3. Remove the cap screws, lock washers, and bushings that secure the brake shoe to the brake lever, then remove the brake shoe (see **Figure 79**).

## Replacing Brake Shoe

---

The brake shoe will need to be replaced when the thickness of the pad measures 1mm or less. The following are indications that the brake pad needs to be replaced: The bandsaw takes noticeably longer to stop when the foot brake is pushed or the foot brake makes metal-to-metal grinding sounds.

Contact our Technical Support Department at (570) 546-9663 to order the replacement brake shoe—Part P0701059 (refer to **Page 73**).

### Items Needed:

Replacement Brake Shoe (Part P0701059) .....	1
Hex Wrench 5mm.....	1
Hex Wrench 6mm.....	1
Wrench 10mm .....	1
Wrench 17mm .....	1

### To replace the brake shoe:

1. DISCONNECT MACHINE FROM POWER!
2. Follow **Steps 1-7** in **Replacing V-Belts** on **Page 57**.

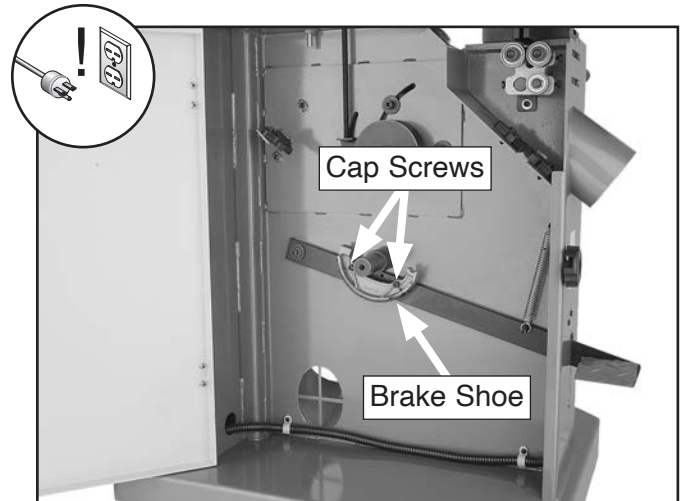

**Figure 79.** Brake shoe location.

4. Install a new brake shoe onto the brake lever with the cap screws, lock washers, and bushings removed in **Step 3**.
5. Re-install the V-belts onto the pulleys, then slide the lower wheel back onto the bearing shaft.
6. Tension the V-belts (see **Tensioning V-Belts** on **Page 56**).
7. Re-install, tension and track the blade, then adjust the upper and lower blade guides and support bearings as needed.
8. Close the wheel covers.



# Aligning Wheels

Wheel alignment is one of the most critical factors for optimal performance from your bandsaw.

Heat, vibration, wandering, blade wear, tire wear and overall bandsaw wear are considerably decreased when the wheels are properly aligned or “coplanar.”

Coplanar wheels automatically track the blade by balancing it on the crown of the wheel. This is known as coplanar tracking.

## Items Needed:

70" Long 2x4 .....	1
Hex Wrenches 5, 6, 8mm.....	1 Ea
Wrenches, 10, 17mm.....	1
Tape Measure.....	1
Coplanarity Gauge .....	1
Straightedge .....	1
Fine Ruler .....	1

## Checking Coplanarity

1. Make the "Coplanarity Gauge" shown in **Figure 80**.

**Note:** For best results, straighten the edges of the 2x4 with a jointer before cutting.

2. DISCONNECT MACHINE FROM POWER!
3. Remove the fence and open both wheel covers.
4. Adjust the blade guides away from the blade, loosen blade tension, remove the table insert and pin, then remove the blade.
5. Remove the table.
6. Re-install the blade (**Page 42**), making sure the guide bearings and support bearings are away from the blade, then tighten your blade to the tension that it will be used during operation.
7. Place your coplanarity gauge up against both wheels in the positions shown in **Figure 81**.

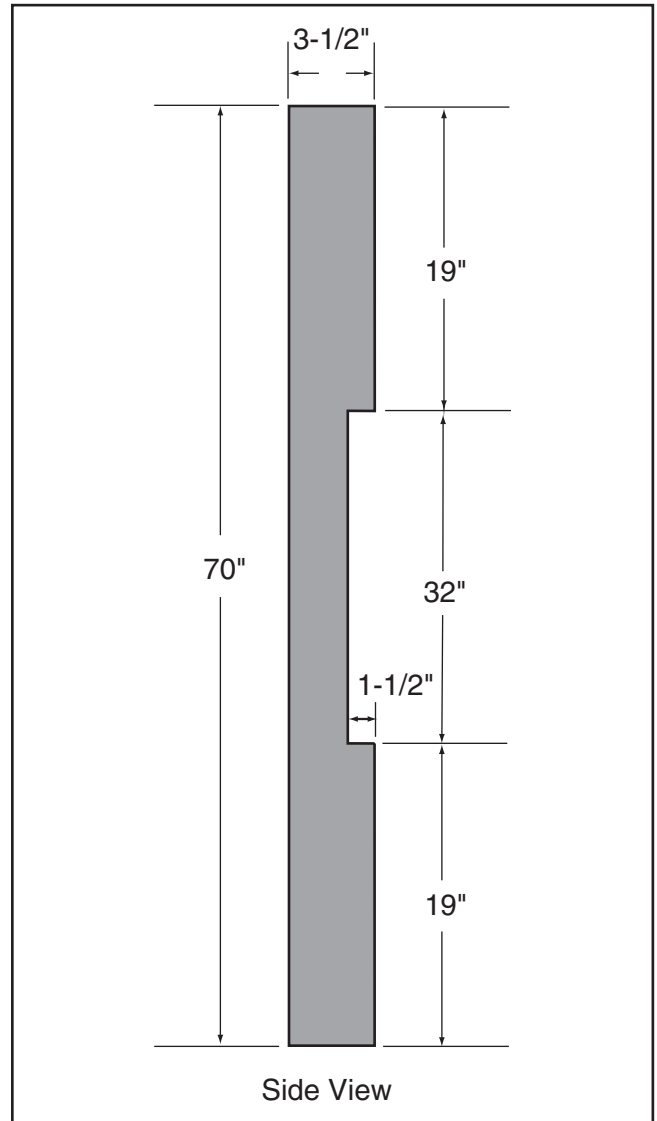

**Figure 80.** Dimensions of coplanarity gauge.

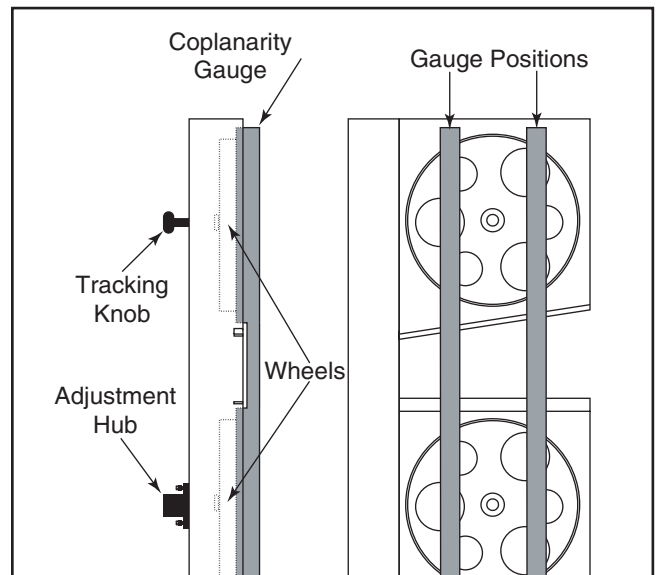

**Figure 81.** Checking for coplanarity.



- If the wheels are coplanar (**Figure 82, A**), the straightedge will evenly touch the top and bottom of both wheels.
- If the wheels are not coplanar (**Figure 82, B**), place the straightedge on the lower wheel first (ensuring that it touches both the top and bottom rim), then adjust the upper wheel tracking knob to make the upper wheel coplanar with the lower wheel.
- If the straightedge does not touch both wheels evenly, the lower wheel needs to be adjusted (**Figure 82, C**) or the upper wheel needs to be shimmed (**Figure 82, D**).

### Shimming Upper Wheel

1. DISCONNECT MACHINE FROM POWER!
2. Make sure the top wheel is adjusted parallel with the bottom wheel.
3. With a straightedge touching both points of the lower wheel, measure the distance away from the upper wheel, which is out of adjustment (see **Figure 83**).
4. Remove the blade from the saw, then remove the upper wheel.
5. Determine how many shim washers you need to compensate for the distance measured in **Step 3** and place them on the wheel shaft.
6. Replace the upper wheel, the original washers, the securing screw, and the blade.
7. Tighten the blade, then check the wheels with the coplanarity gauge. (Wheel coplanarity changes as the blade is tightened, so it is best to check the wheel alignment when the blade is tensioned as it would be for normal operations.)
8. When the wheels are coplanar, place a mark on each wheel where you held the straight-edge. This assures repeated accuracy every time you adjust your wheels.

**Note:** When wheels are properly coplanar, the blade may not be centered on the crown of the wheel, but it will be balanced.

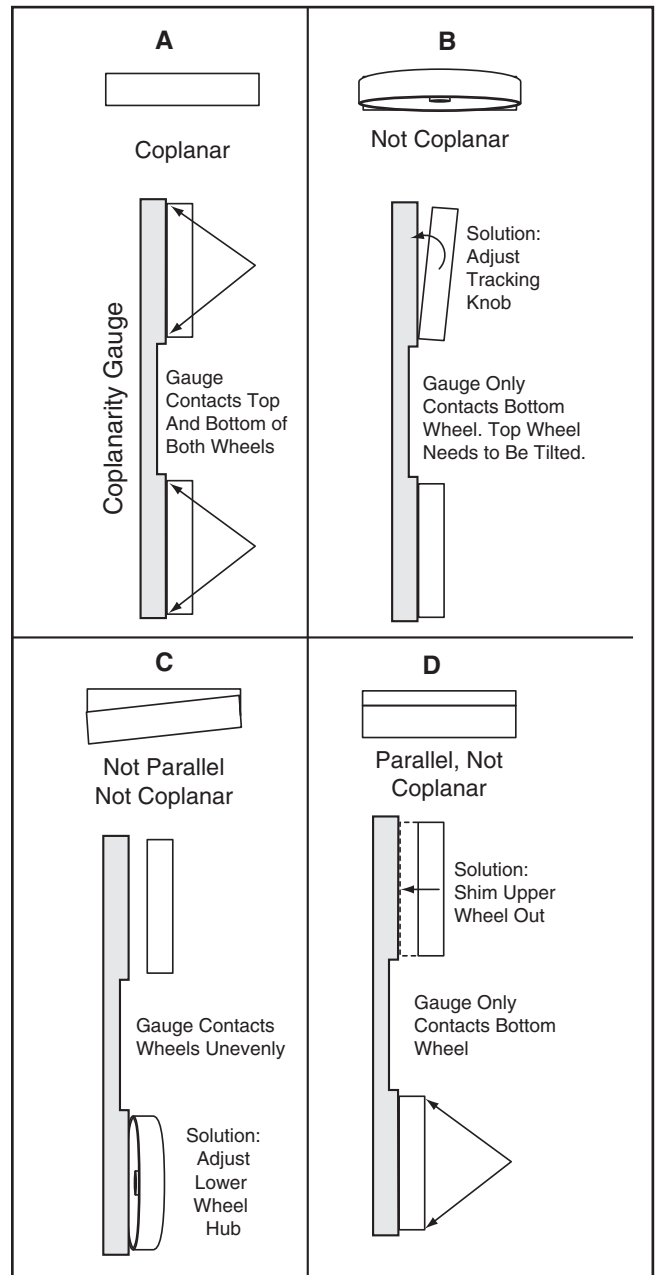

**Figure 82.** Coplanarity diagram.

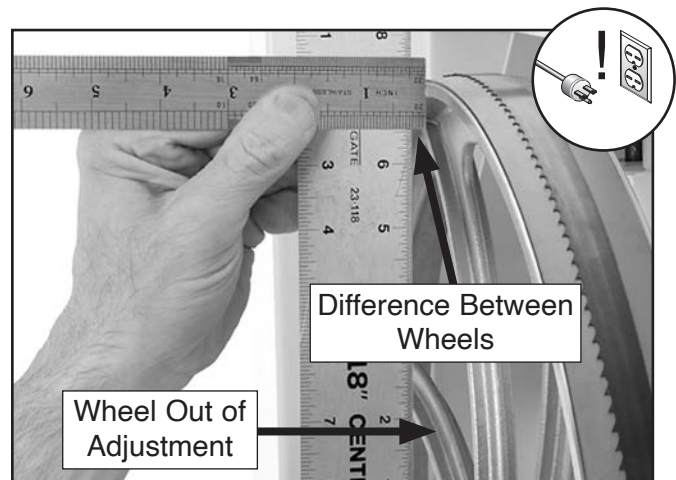

**Figure 83.** Determining distance needed to shim upper wheel.



## Adjusting Lower Wheel

Only do this procedure if you cannot make the wheels coplanar with the tracking knob or by shimming the upper wheel. Make sure the upper wheel is adjusted as close as possible to being coplanar with the lower wheel before beginning. Do this procedure with the blade fully tensioned.

### To adjust the lower wheel:

1. DISCONNECT MACHINE FROM POWER!
2. Loosen the jam nuts on the lower wheel adjustment hub (see **Figure 84**).

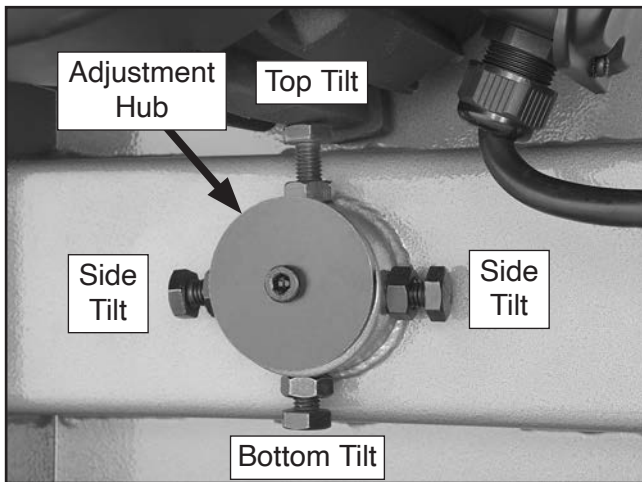

**Figure 84.** Lower wheel adjustment control.

3. Loosen one tilt adjustment hex bolt, then tighten the opposing hex bolt approximately an equal amount.
4. Check the wheels with the coplanarity gauge, then adjust the lower wheel at the hub as needed until it is parallel and coplanar with the top wheel.
5. Tighten the jam nuts to lock the tilt adjustment hex bolts in position.



# SECTION 8: WIRING

These pages are current at the time of printing. However, in the spirit of improvement, we may make changes to the electrical systems of future machines. Compare the manufacture date of your machine to the one stated in this manual, and study this section carefully.

If there are differences between your machine and what is shown in this section, call Technical Support at (570) 546-9663 for assistance BEFORE making any changes to the wiring on your machine. An updated wiring diagram may be available. **Note:** *Please gather the serial number and manufacture date of your machine before calling. This information can be found on the main machine label.*

## WARNING

### Wiring Safety Instructions

**SHOCK HAZARD.** Working on wiring that is connected to a power source is extremely dangerous. Touching electrified parts will result in personal injury including but not limited to severe burns, electrocution, or death. Disconnect the power from the machine before servicing electrical components!

**MODIFICATIONS.** Modifying the wiring beyond what is shown in the diagram may lead to unpredictable results, including serious injury or fire. This includes the installation of unapproved after-market parts.

**WIRE CONNECTIONS.** All connections must be tight to prevent wires from loosening during machine operation. Double-check all wires disconnected or connected during any wiring task to ensure tight connections.

**CIRCUIT REQUIREMENTS.** You MUST follow the requirements at the beginning of this manual when connecting your machine to a power source.

**WIRE/COMPONENT DAMAGE.** Damaged wires or components increase the risk of serious personal injury, fire, or machine damage. If you notice that any wires or components are damaged while performing a wiring task, replace those wires or components.

**MOTOR WIRING.** The motor wiring shown in these diagrams is current at the time of printing but may not match your machine. If you find this to be the case, use the wiring diagram inside the motor junction box.















**CAPACITORS/INVERTERS.** Some capacitors and power inverters store an electrical charge for up to 10 minutes after being disconnected from the power source. To reduce the risk of being shocked, wait at least this long before working on capacitors.

**EXPERIENCING DIFFICULTIES.** If you are experiencing difficulties understanding the information included in this section, contact our Technical Support at (570) 546-9663.

#### NOTICE

The photos and diagrams included in this section are best viewed in color. You can view these pages in color at [www.grizzly.com](http://www.grizzly.com).

#### COLOR KEY

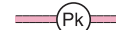
BLACK 	BLUE 	YELLOW 	LIGHT BLUE 
WHITE 	BROWN 	YELLOW GREEN 	BLUE WHITE 
GREEN 	GRAY 	PURPLE 	TURQUOISE 
RED 	ORANGE 	PINK 	



# Electrical Overview

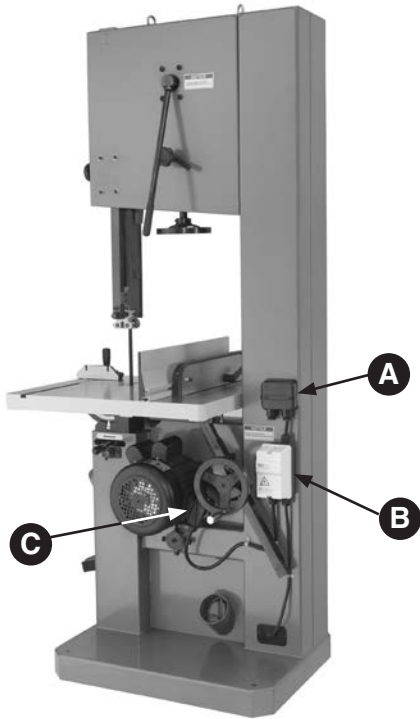

Rear View

	Description	Wiring Diagram Page Reference
<b>A</b>	Power Junction Box	69
<b>B</b>	Magnetic Switch	69
<b>C</b>	Motor Junction Box	69
<b>D</b>	Control Panel	70
<b>E</b>	Guide Post Elevation Control	70
<b>F</b>	Upper Door Safety Switch	71
<b>G</b>	Guide Post Elevation Motor	71
<b>H</b>	Brake Switch	71

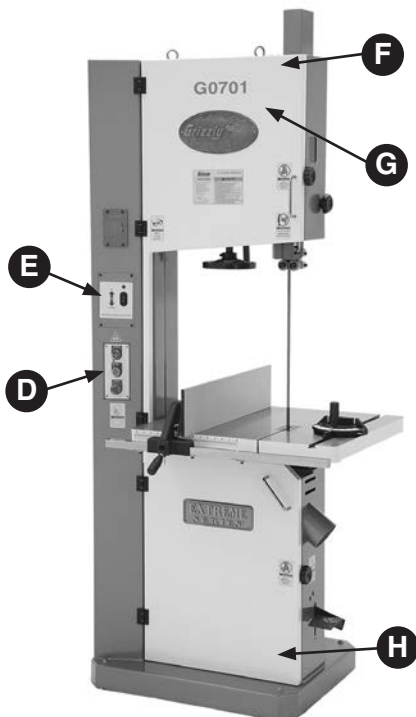

Front View

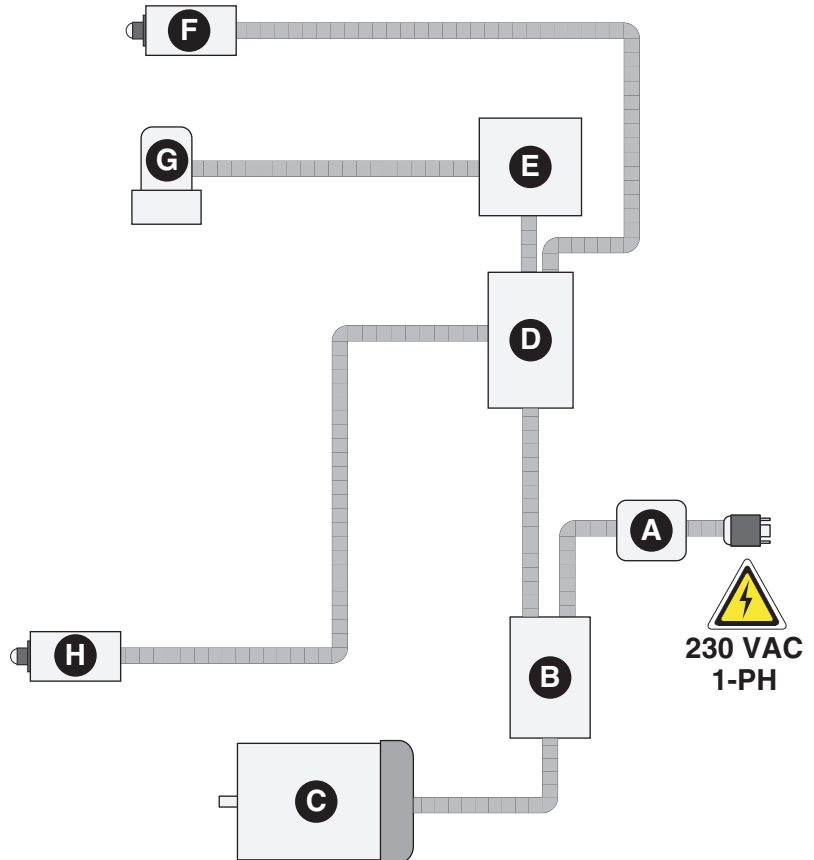

# Junction Box, Motor & Magnetic Switch



Figure 85. Magnetic switch wiring.

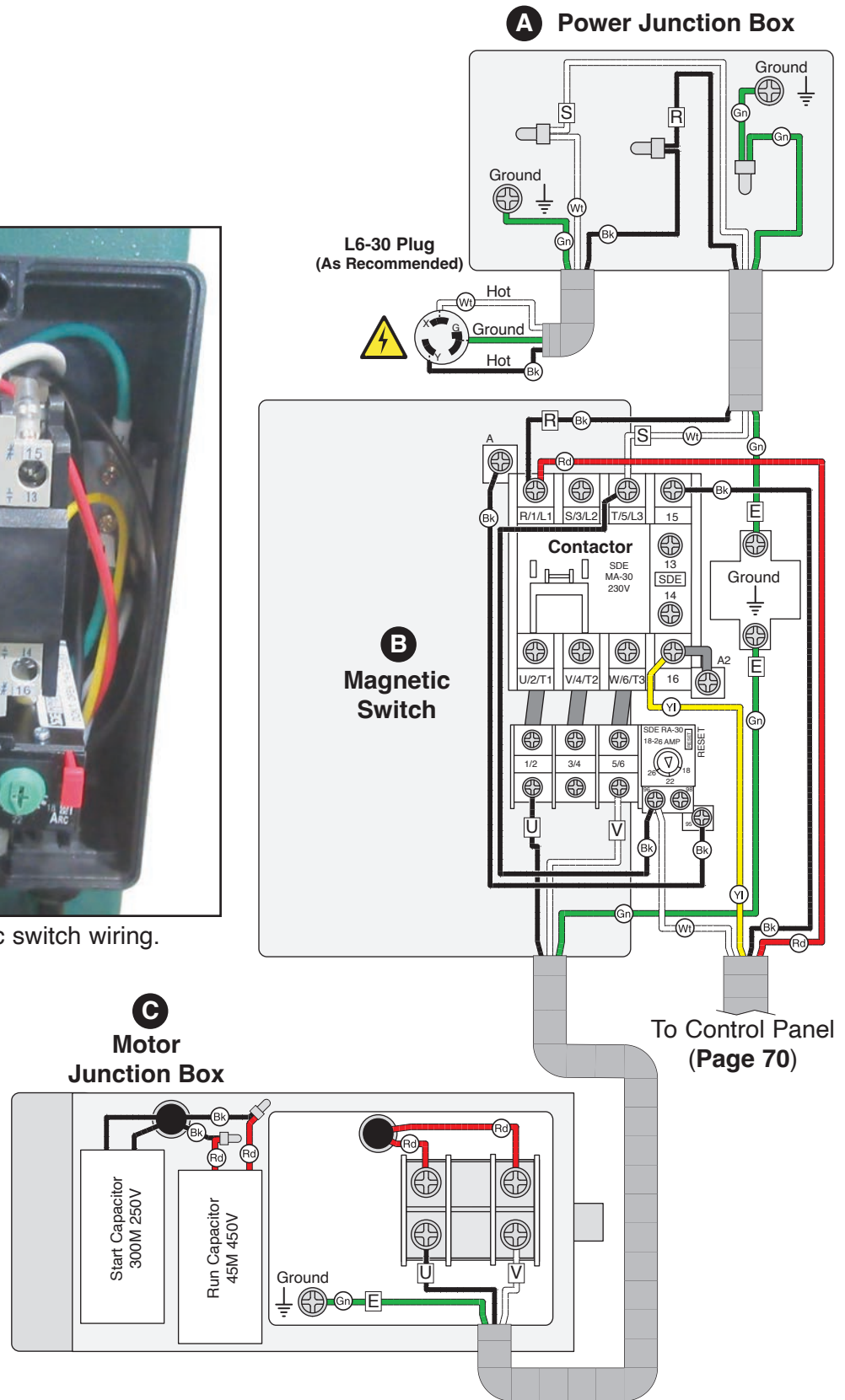

# Control Panel & Guide Post Control

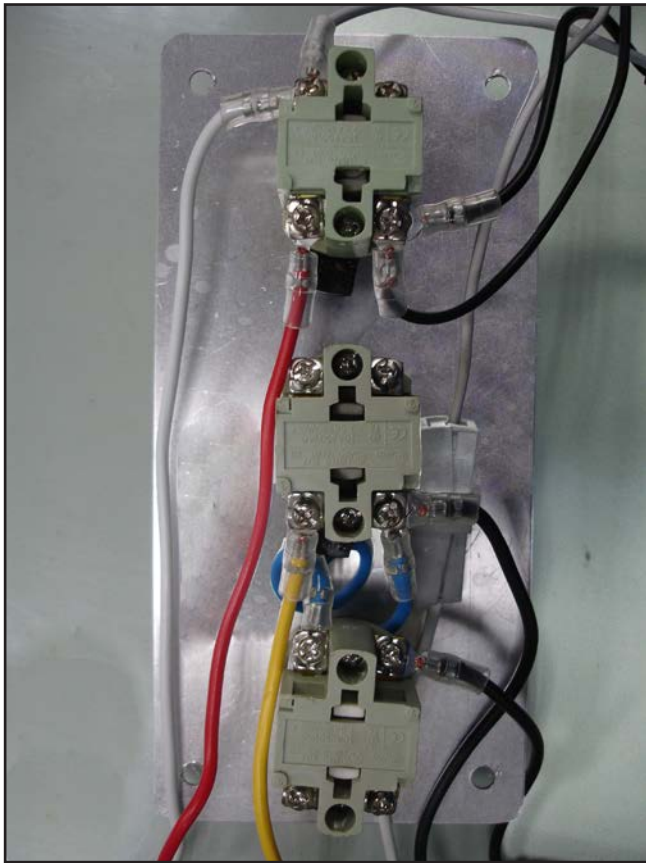

Figure 86. Control panel wiring.

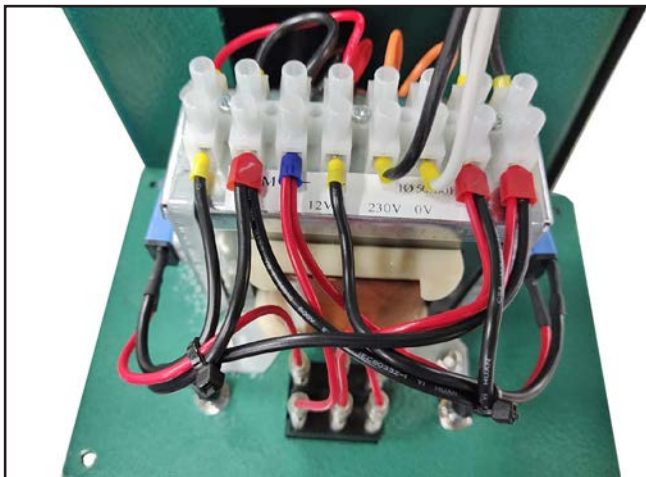
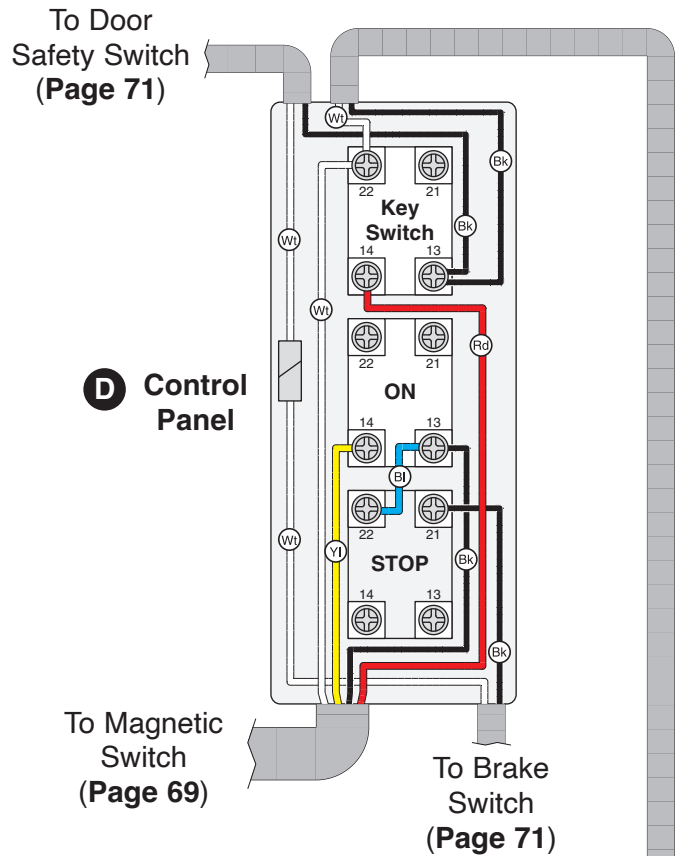
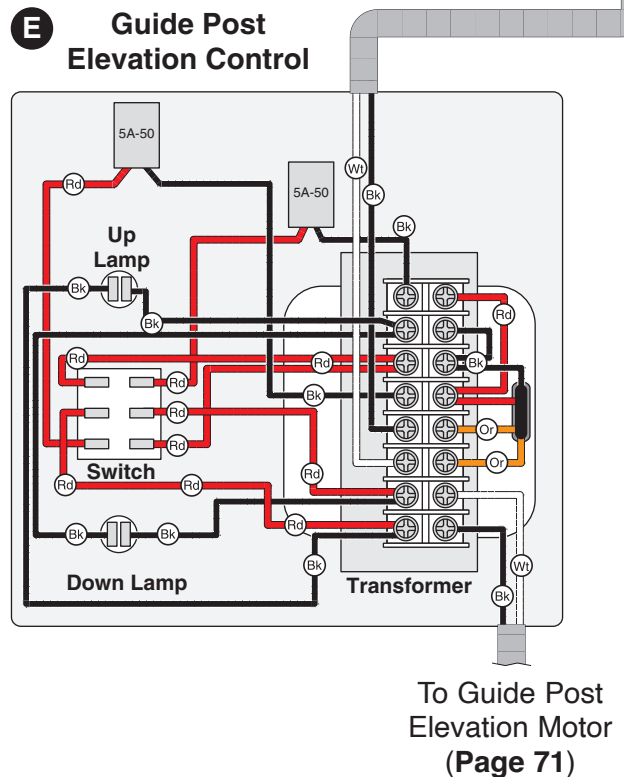

Figure 87. Guide post elevation control wiring.



# Door Switch, Post Motor & Brake Switch

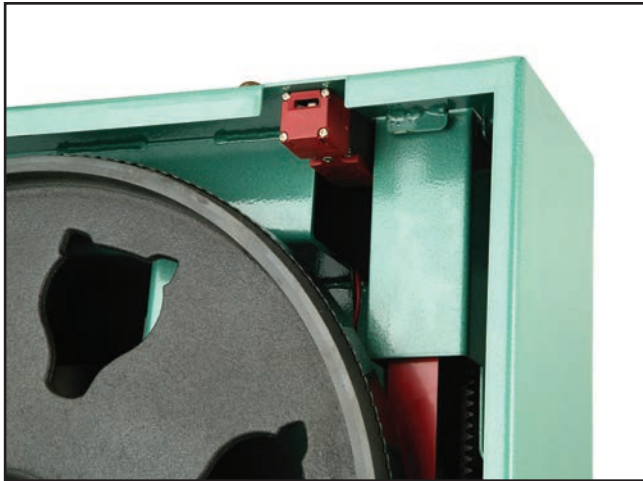

Figure 88. Upper door safety switch wiring.

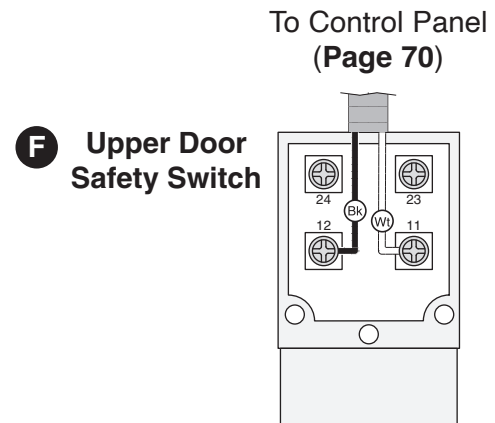

Figure 89. Guide post elevation motor wiring.

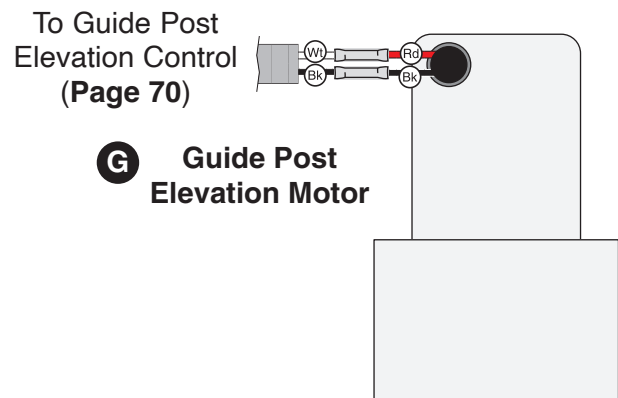
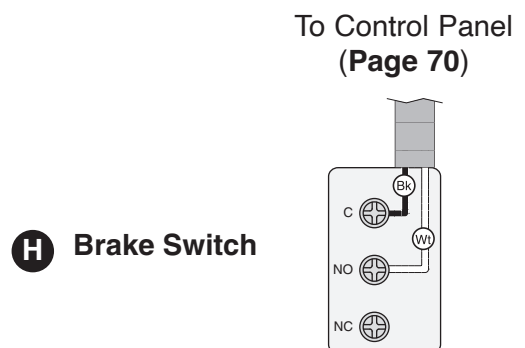

Figure 90. Brake switch wiring.



# SECTION 9: PARTS

We do our best to stock replacement parts when possible, but we cannot guarantee that all parts shown are available for purchase. Call (800) 523-4777 or visit [www.grizzly.com/parts](http://www.grizzly.com/parts) to check for availability.

## Frame

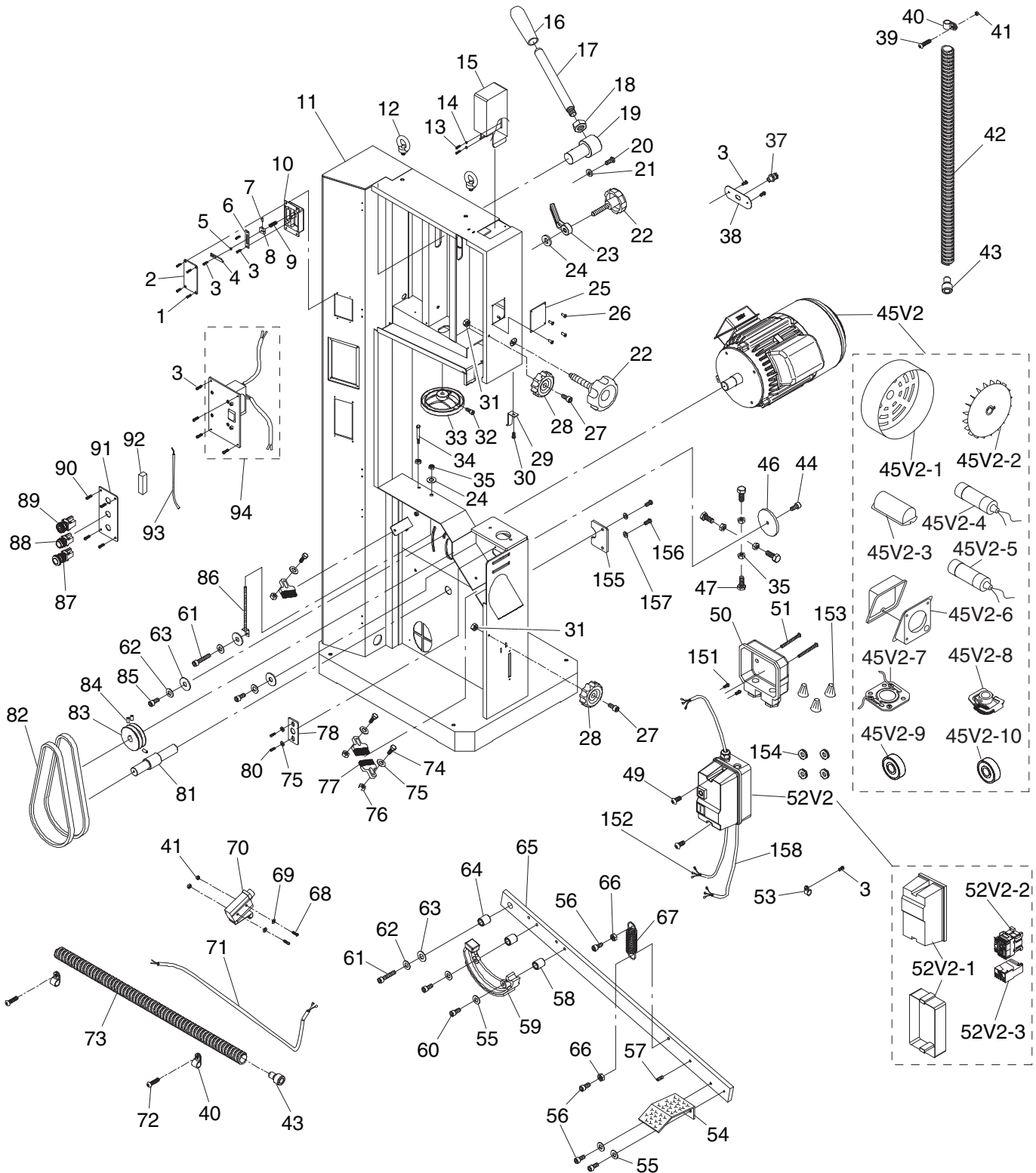

# Frame Parts List

REF	PART #	DESCRIPTION
1	P0701001	TAP SCREW M4 X 8
2	P0701002	TENSION SCALE PLATE
3	P0701003	TAP SCREW M4 X 10
4	P0701004	TENSION POINTER
5	P0701005	FLAT WASHER 4MM
6	P0701006	TENSION SCALE BRACKET
7	P0701007	ROLL PIN 3 X 12
8	P0701008	TENSION POINTER BRACKET
9	P0701009	TORSION SPRING
10	P0701010	TENSION SCALE BOX
11	P0701011	FRAME
12	P0701012	LIFTING EYE BOLT M12-1.75 X 20
13	P0701013	SHOULDER SCREW M4-.7 X 6
14	P0701014	PLASTIC FLAT WASHER 13 X 6 X 1.5
15	P0701015	GUIDE POST TOP CAP
16	P0701016	KNOB
17	P0701017	LEVER
18	P0701018	HEX NUT M16-2
19	P0701019	LEVER HUB
20	P0701020	CAP SCREW M10-1.5 X 20
21	P0701021	LOCK WASHER 10MM
22	P0701022	STAR KNOB BOLT M10-1.5 X 55
23	P0701023	LEVER
24	P0701024	FLAT WASHER 10MM
25	P0701025	CLEAR PLASTIC WINDOW
26	P0701026	RIVET 3.2 X 10
27	P0701027	CAP SCREW M6-1 X 20
28	P0701028	STAR KNOB
29	P0701029	POINTER
30	P0701030	FLANGE SCREW M5-.8 X 10
31	P0701031	LOCK NUT M6-1
32	P0701032	CAP SCREW M6-1 X 25
33	P0701033	HANDWHEEL
34	P0701034	HEX BOLT M10-1.5 X 110
35	P0701035	HEX NUT M10-1.5
36	P0701036	FLAT WASHER 10MM
37	P0701037	STRAIN RELIEF
38	P0701038	PLATE
39	P0701039	PHLP HD SCR M4-.7 X 16
40	P0701040	CORD CLAMP 5/8"
41	P0701041	HEX NUT M4-.7
42	P0701042	FLEXIBLE TUBE 1/2" X 43-1/2"
43	P0701043	STRAIN RELIEF
44	P0701044	CAP SCREW M8-1.25 X 25
45V2	P0701045V2	MOTOR 5HP 230V 1PH V2.03.12

REF	PART #	DESCRIPTION
45V2-1	P0701045V2-1	MOTOR FAN COVER
45V2-2	P0701045V2-2	MOTOR FAN
45V2-3	P0701045V2-3	CAPACITOR COVER
45V2-4	P0701045V2-4	S CAPACITOR 300M 250V
45V2-5	P0701045V2-5	R CAPACITOR 45M 450V
45V2-6	P0701045V2-6	MOTOR WIRING JUNCTION BOX
45V2-7	P0701045V2-7	CONTACT PLATE
45V2-8	P0701045V2-8	CENTRIFUGAL SWITCH 1720
45V2-9	P0701045V2-9	BALL BEARING 6206 2RS
45V2-10	P0701045V2-10	BALL BEARING 6204ZZ
46	P0701046	WHEEL ADJUSTMENT BRACKET
47	P0701047	HEX BOLT M10-1.5 X 35
50	P0701050	JUNCTION BOX
51	P0701051	FLANGE SCREW M5-.8 X 50
52V2	P0701052V2	MAG SWITCH ASSY MPE-30 V2.03.12
52V2-1	P0701052V2-1	MAG SWITCH HOUSING
52V2-2	P0701052V2-2	CONTACTOR SDE MA-30 220V-240V
52V2-3	P0701052V2-3	OL RELAY SDE RA-30A 18-26A
53	P0701053	CORD CLAMP 1/2"
54	P0701054	BRAKE PEDAL
55	P0701055	LOCK WASHER 6MM
56	P0701056	CAP SCREW M6-1 X 16
57	P0701057	LOCKING SET SCREW M7-1 X 10
58	P0701058	BUSHING
59	P0701059	BRAKE SHOE
60	P0701060	CAP SCREW M6-1 X 25
61	P0701061	CAP SCREW M8-1.25 X 30
62	P0701062	LOCK WASHER 8MM
63	P0701063	FLAT WASHER 8MM
64	P0701064	BUSHING
65	P0701065	BRAKE LEVER
66	P0701066	HEX NUT M6-1
67	P0701067	EXTENSION SPRING
68	P0701068	PHLP HD SCR M4-.7 X 30
69	P0701069	FLAT WASHER 4MM
70	P0701070	BRAKE SWITCH
71	P0701071	BRAKE SWITCH CORD
72	P0701072	TAP SCREW M4 X 8
73	P0701073	FLEXIBLE TUBE 1/2 X 44
74	P0701074	HEX BOLT M6-1 X 25
75	P0701075	FLAT WASHER 6MM
76	P0701076	LOCK NUT M6-1
77	P0701077	WHEEL BRUSH
78	P0701078	LOWER WHEEL SUPPORT



# Frame Parts List (Cont.)

REF	PART #	DESCRIPTION
80	P0701080	CAP SCREW M6-1 X 16
81	P0701081	LOWER WHEEL SHAFT
82	P0701082	V-BELT 17-330, A32
83	P0701083	MOTOR PULLEY
84	P0701084	SET SCREW M6-1 X 12
85	P0701085	CAP SCREW M8-1.25 X 25
86	P0701086	BRUSH ADJUSTMENT STUD
87	P0701087	ON BUTTON
88	P0701088	OFF BUTTON
89	P0701089	KEYED POWER SWITCH
90	P0701090	PHLP HD SCR M5-.8 X 10
91	P0701091	CONTROL PANEL

REF	PART #	DESCRIPTION
92	P0701092	CORD CONNECTOR
93	P0701093	CONTROL PANEL CORD
94	P0701094	GUIDE POST ELEVATION SWITCH
151	P0701151	PHLP HD SCR M4-.7 X 10
152	P0701152	MOTOR CORD 12G 3W
153	P0701153	WIRE NUT P3
154	P0701154	EXT TOOTH WASHER 5MM
155	P0701155	ADJUSTMENT PLATE
156	P0701156	HEX BOLT M5-.8 X 12
157	P0701157	FLAT WASHER 5MM
158	P0701158	CONTROL PANEL CORD 12G 4W



# Wheels

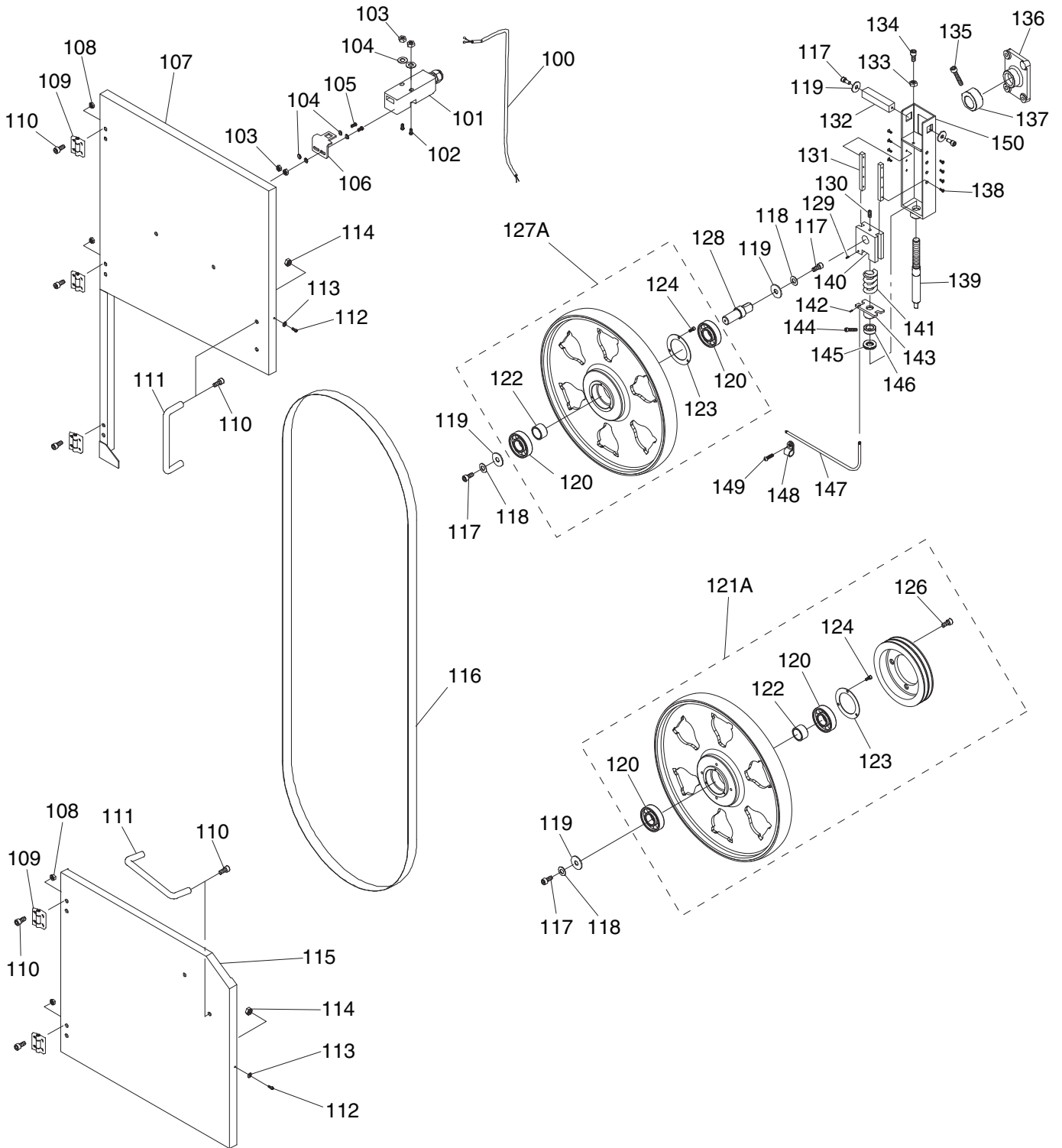

# Wheels Parts List

REF	PART #	DESCRIPTION
100	P0701100	DOOR SAFETY SWITCH CORD
101	P0701101	DOOR SAFETY SWITCH
102	P0701102	FLANGE SCREW M4-.7 X 35
103	P0701103	HEX NUT M4-.7
104	P0701104	FLAT WASHER 4MM
105	P0701105	PHLP HD SCR M4-.7 X 10
106	P0701106	DOOR SAFETY SWITCH BRACKET
107	P0701107	UPPER WHEEL DOOR
108	P0701108	FLANGE NUT M5-.8
109	P0701109	DOOR HINGE
110	P0701110	CAP SCREW M5-.8 X 12
111	P0701111	DOOR HANDLE
112	P0701112	CAP SCREW M6-1 X 16
113	P0701113	LOCK WASHER 6MM
114	P0701114	LOCK NUT M6-1
115	P0701115	LOWER WHEEL DOOR
116	P0701116	SAW BLADE 166" X 1-3/8" X 0.035"
117	P0701117	CAP SCREW M8-1.25 X 25
118	P0701118	LOCK WASHER 6MM
119	P0701119	SHAFT FLAT WASHER 8MM
120	P0701120	BALL BEARING 6306-2RS
121A	P0701121A	LOWER WHEEL ASSEMBLY
122	P0701122	BUSHING
123	P0701123	BEARING END CAP
124	P0701124	PHLP HD SCR M6-1 X 16

REF	PART #	DESCRIPTION
126	P0701126	CAP SCREW M8-1.25 X 20
127A	P0701127A	UPPER WHEEL ASSEMBLY
128	P0701128	UPPER WHEEL SHAFT
129	P0701129	SET SCREW M5-.8 X 5
130	P0701130	SET SCREW M10-1.5 X 16
131	P0701131	GIB
132	P0701132	SQUARE SHAFT
133	P0701133	HEX NUT M8-1.25
134	P0701134	CAP SCREW M8-1.25 X 50
135	P0701135	CAP SCREW M8-1.25 X 30
136	P0701136	BRACKET
137	P0701137	CAM
138	P0701138	FLAT HD SCR M5-.8 X 16
139	P0701139	TENSION ADJUSTMENT BOLT
140	P0701140	GUIDE BLOCK
141	P0701141	COMPRESSION SPRING
142	P0701142	SET SCREW M4-.7 X 6
143	P0701143	SPRING PLATE
144	P0701144	CAP SCREW M8-1.25 X 40
145	P0701145	BEARING END CAP
146	P0701146	THRUST BEARING 51105
147	P0701147	TENSION CABLE
148	P0701148	CORD CLAMP 5/16"
149	P0701149	TAP SCREW M4 X 10
150	P0701150	UPPER WHEEL HINGE



# Table

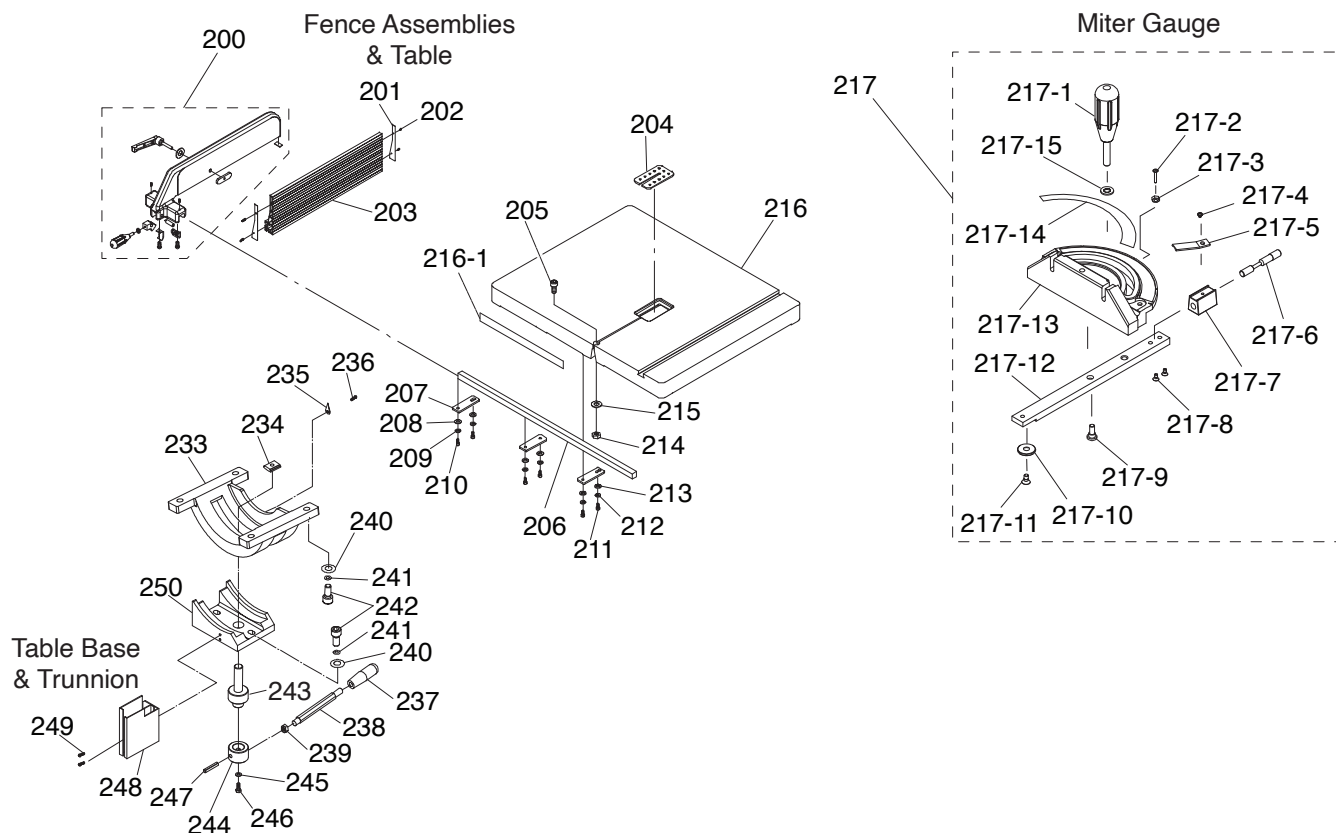

REF	PART #	DESCRIPTION
200	P0701200	FENCE ASSEMBLY
201	P0701201	END CAP
202	P0701202	TAP SCREW M4 X 10
203	P0701203	RESAW FENCE ALUMINUM
204	P0701204	TABLE INSERT
205	P0701205	CAP SCREW M8-1.25 X 50
206	P0701206	FENCE RAIL
207	P0701207	FENCE RAIL PLATE
208	P0701208	FLAT WASHER 6MM
209	P0701209	LOCK WASHER 6MM
210	P0701210	HEX BOLT M6-1 X 20
211	P0701211	HEX BOLT M8-1.25 X 20
212	P0701212	LOCK WASHER 8MM
213	P0701213	FLAT WASHER 8MM
214	P0701214	HEX NUT M8-1.25
215	P0701215	FLAT WASHER 8MM
216	P0701216	TABLE
216-1	P0701216-1	FENCE SCALE
217	P0701217	MITER GAUGE ASSEMBLY
217-1	P0701217-1	MITER HANDLE
217-2	P0701217-2	PHLP HD SCR M4-.7 X 16
217-3	P0701217-3	HEX NUT M4-.7
217-4	P0701217-4	PHLP HD SCR 10-24 X 1/4
217-5	P0701217-5	POINTER
217-6	P0701217-6	INDEX SHAFT
217-7	P0701217-7	INDEX SHAFT BRACKET

REF	PART #	DESCRIPTION
217-8	P0701217-8	PHLP HD SCR 10-24 X 1/4
217-9	P0701217-9	SHOULDER SCREW
217-10	P0701217-10	SLOT WASHER
217-11	P0701217-11	FLAT HD SCR M6-1 X 8
217-12	P0701217-12	GUIDE BAR
217-13	P0701217-13	MITER GAUGE BODY
217-14	P0701217-14	MITER SCALE
217-15	P0701217-15	FLAT WASHER 8MM
233	P0701233	TABLE BASE
234	P0701234	TRUNNION T-NUT
235	P0701235	POINTER
236	P0701236	PHLP HD SCR M4-.7 X 10
237	P0701237	TRUNNION HANDLE M12-1.75
238	P0701238	HANDLE SHAFT
239	P0701239	HEX NUT M12-1.75
240	P0701240	FLAT WASHER 10MM
241	P0701241	LOCK WASHER 10MM
242	P0701242	CAP SCREW M10-1.5 X 35
243	P0701243	PIVOT SHAFT
244	P0701244	LOCK COLLAR
245	P0701245	LOCK WASHER 8MM
246	P0701246	HEX BOLT M8-1.25 X 20
247	P0701247	ROLL PIN 6 X 36
248	P0701248	LOWER BLADE GUARD
249	P0701249	FLANGE BOLT M6-1 X 10
250	P0701250	TRUNNION



# Guides

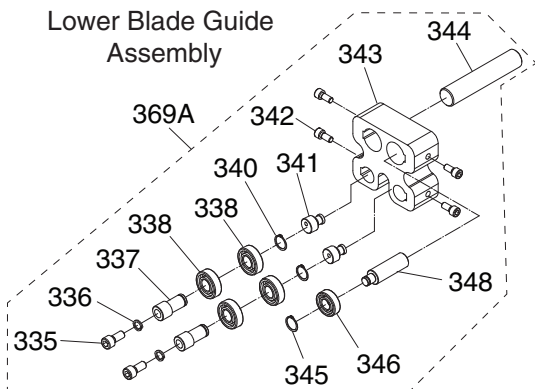
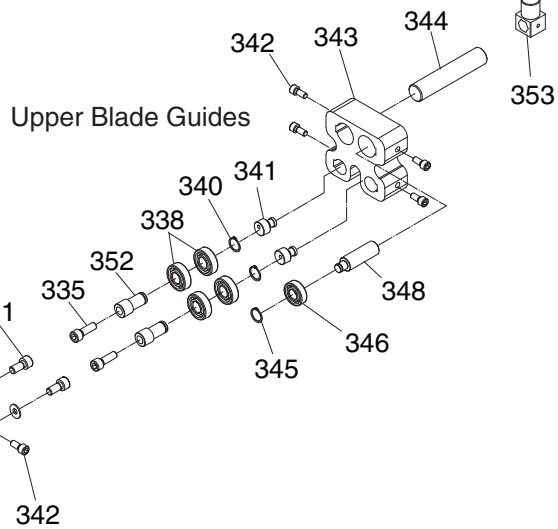
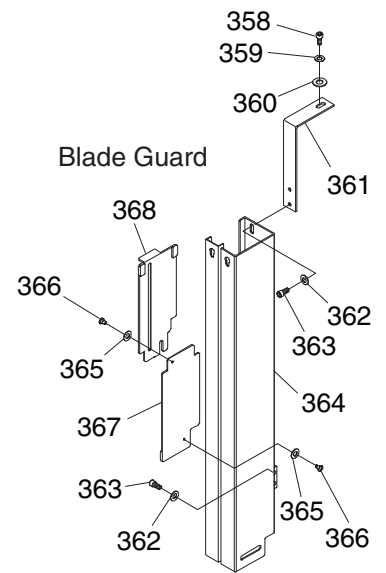
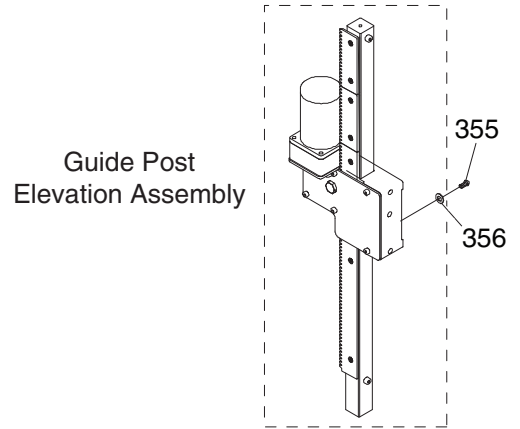
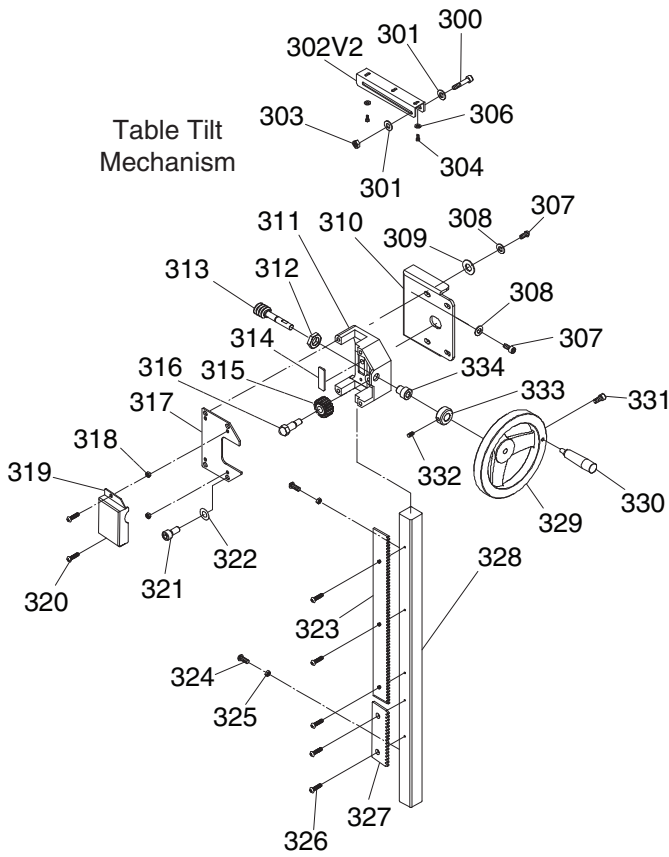

# Guides Parts List

REF	PART #	DESCRIPTION
300	P0701300	HEX BOLT M8-1.25 X 55
301	P0701301	FLAT WASHER 8MM
302V2	P0701302V2	SLIDING BRACKET 300MM V2.11.11
303	P0701303	LOCK NUT M8-1.25
304	P0701304	CAP SCREW M6-1 X 10
306	P0701306	FLAT WASHER 6MM
307	P0701307	CAP SCREW M8-1.25 X 25
308	P0701308	LOCK WASHER 8MM
309	P0701309	FLAT WASHER 8MM
310	P0701310	SUPPORT BRACKET
311	P0701311	GUIDE BRACKET
312	P0701312	HEX NUT M16-1.5
313	P0701313	WORM SHAFT
314	P0701314	PLATE
315	P0701315	PINION GEAR
316	P0701316	SHOULDER BOLT
317	P0701317	PROTECTIVE PLATE
318	P0701318	HEX NUT M5-.8
319	P0701319	PROTECTIVE COVER
320	P0701320	FLANGE BOLT M5-.8 X 10
321	P0701321	CAP SCREW M8-1.25 X 16
322	P0701322	LOCK WASHER 8MM
323	P0701323	RACK
324	P0701324	PHLP HD SCR M4-.7 X 10
325	P0701325	HEX NUT M4-.7
326	P0701326	FLAT HD SCR M4-.7 X 10
327	P0701327	RACK EXTENSION
328	P0701328	TILT GUIDE POST
329	P0701329	HANDWHEEL
330	P0701330	HANDWHEEL HANDLE 3/8-16 X 1/2
331	P0701331	CAP SCREW M6-1 X 25
332	P0701332	SET SCREW M5-.8 X 5
333	P0701333	LOCK COLLAR
334	P0701334	BUSHING

REF	PART #	DESCRIPTION
335	P0701335	CAP SCREW M6-1 X 40
336	P0701336	LOCK WASHER 6MM
337	P0701337	STEPPED BUSHING
338	P0701338	BALL BEARING 6202ZZ
339	P0701339	SPACER
340	P0701340	EXT RETAINING RING 15MM
341	P0701341	ECCENTRIC BUSHING
342	P0701342	CAP SCREW M6-1 X 16
343	P0701343	GUIDE BLOCK
344	P0701344	BLADE GUIDE SHAFT
345	P0701345	EXT RETAINING RING 12MM
346	P0701346	BALL BEARING 6201ZZ
347	P0701347	SPACER
348	P0701348	STEPPED BUSHING
349	P0701349	LOWER GUIDE BLOCK BRACKET
350	P0701350	FLAT WASHER 6MM
351	P0701351	CAP SCREW M6-1 X 16
352	P0701352	STEPPED BUSHING
353	P0701353	UPPER GUIDE BLOCK BRACKET
355	P0701355	CAP SCREW M8-1.25 X 35
356	P0701356	FLAT WASHER 8MM
358	P0701358	CAP SCREW M6-1 X 16
359	P0701359	LOCK WASHER 6MM
360	P0701360	FLAT WASHER 6MM
361	P0701361	SUPPORT BRACKET
362	P0701362	FLAT WASHER 6MM
363	P0701363	CAP SCREW M6-1 X 10
364	P0701364	UPPER BLADE GUARD
365	P0701365	PLASTIC FLAT WASHER 13 X 6 X 1.5
366	P0701366	SHOULDER SCREW M4-.7 X 6
367	P0701367	BLADE GUARD COVER EXTERNAL
368	P0701368	BLADE GUARD COVER INTERNAL
369A	P0701369A	LOWER BLADE GUIDE ASSY



# Guide Post Elevation Assembly

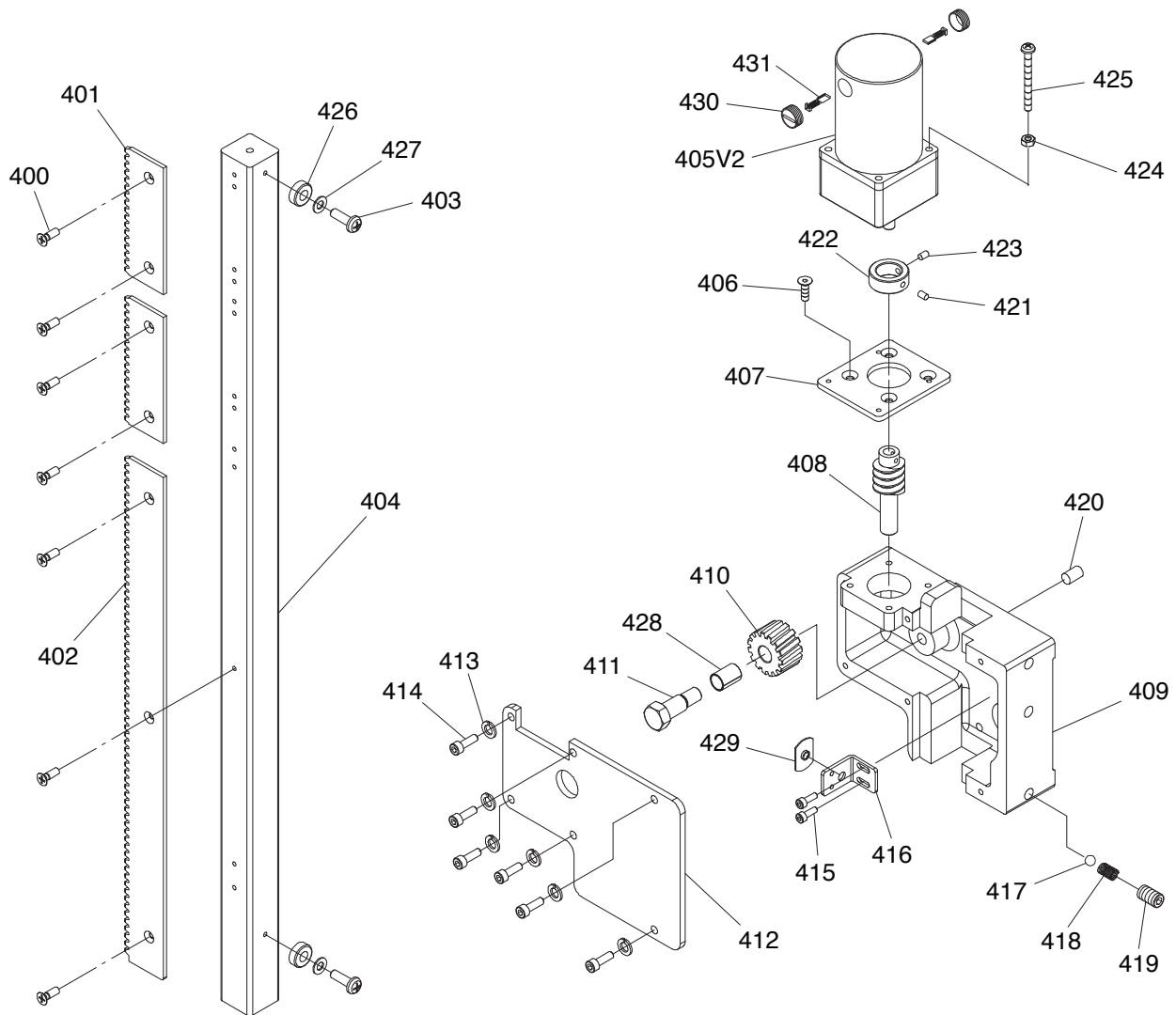

REF	PART #	DESCRIPTION
400	P0701400	FLAT HD SCR M4-.7 X 12
401	P0701401	RACK EXTENSION
402	P0701402	RACK
403	P0701403	FLANGE SCREW M6-1 X 16
404	P0701404	UPPER GUIDE POST
405V2	P0701405V2	GUIDE POST MOTOR 40W 12VDC V2.11.24
406	P0701406	FLAT HD SCR M5-.8 X 16
407	P0701407	MOTOR MOUNT
408	P0701408	WORM SHAFT
409	P0701409	ELEVATION GEAR HOUSING
410	P0701410	PINION GEAR
411	P0701411	SHOULDER BOLT
412	P0701412	GEAR HOUSING COVER
413	P0701413	LOCK WASHER 5MM
414	P0701414	CAP SCREW M5-.8 X 16
415	P0701415	PHLP HD SCR M4-.7 X 8

REF	PART #	DESCRIPTION
416	P0701416	BRACKET
417	P0701417	STEEL BALL
418	P0701418	COMPRESSION SPRING
419	P0701419	SET SCREW M10-1.5 X 10
420	P0701420	NYLON SET SCREW M7-1 X 10
421	P0701421	SET SCREW M4-.7 X 8
422	P0701422	LOCK COLLAR
423	P0701423	SET SCREW M4-.7 X 6
424	P0701424	HEX NUT M5-.8
425	P0701425	PHLP HD SCR M5-.8 X 55
426	P0701426	RUBBER SPACER 6MM
427	P0701427	FLAT WASHER 6MM
428	P0701428	GEAR BUSHING
429	P0701429	NYLON INSERT
430	P0701430	MOTOR BRUSH CAP
431	P0701431	MOTOR BRUSH



# Fence Assembly & Tools

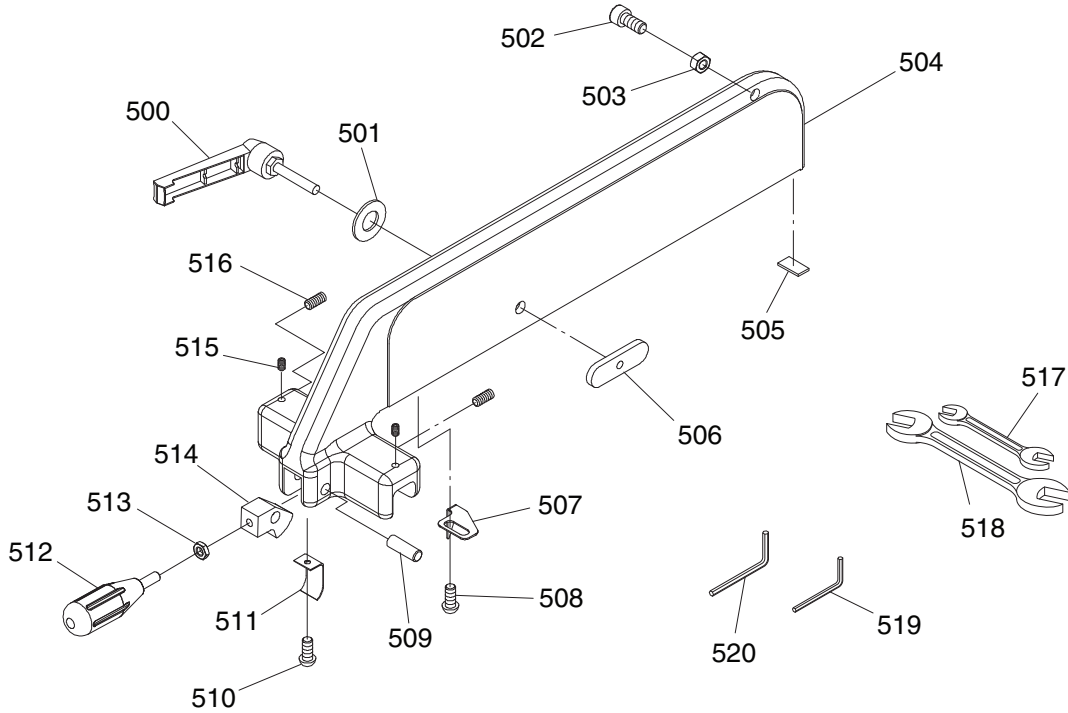

REF	PART #	DESCRIPTION
500	P0701500	LOCK LEVER M8-1.25 X 45
501	P0701501	FLAT WASHER 8MM
502	P0701502	CAP SCREW M8-1.25 X 20
503	P0701503	HEX NUT M8-1.25
504	P0701504	FENCE
505	P0701505	NYLON PAD
506	P0701506	RESAW FENCE T-BAR
507	P0701507	POINTER
508	P0701508	FLANGE SCREW M5-.8 X 8
509	P0701509	SHAFT
510	P0701510	FLANGE SCREW M4-.7 X 8

REF	PART #	DESCRIPTION
511	P0701511	SPRING PLATE
512	P0701512	FENCE HANDLE M8-1.25 X 20
513	P0701513	HEX NUT M8-1.25
514	P0701514	LOCKING CLAMP
515	P0701515	SET SCREW NYLON M6-1 X 10
516	P0701516	SET SCREW M8-1.25 X 12
517	P0701517	WRENCH 10/13MM
518	P0701518	WRENCH 17/19MM
519	P0701519	HEX WRENCH 5MM
520	P0701520	HEX WRENCH 6MM



# Labels & Cosmetics

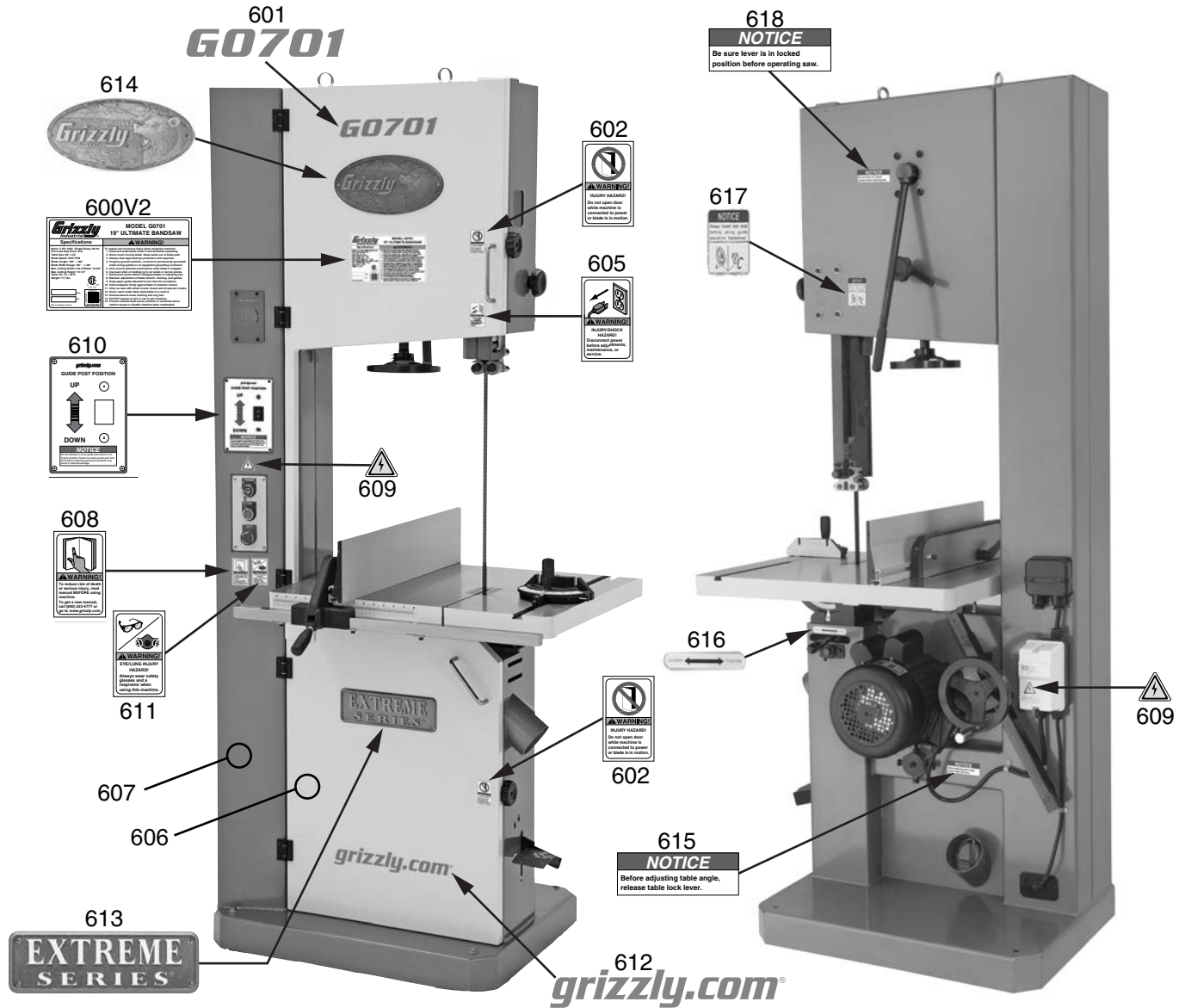

REF	PART #	DESCRIPTION
600V2	P0701600V2	MACHINE ID LABEL (CSA) V2.02.18
601	P0701601	MODEL NUMBER LABEL
602	P0701602	DOOR WARNING LABEL
605	P0701605	DISCONNECT POWER LABEL
606	P0701606	TOUCH-UP PAINT, GRIZZLY PUTTY
607	P0701607	TOUCH-UP PAINT, GRIZZLY GREEN
608	P0701608	READ MANUAL LABEL
609	P0701609	ELECTRICITY LABEL
610	P0701610	GUIDE POST ELEVATION LABEL

REF	PART #	DESCRIPTION
611	P0701611	GLASSES/RESPIRATOR LABEL
612	P0701612	GRIZZLY.COM LABEL
613	P0701613	EXTREME SERIES PLATE
614	P0701614	GRIZZLY NAMEPLATE
615	P0701615	TABLE LOCK NOTICE
616	P0701616	ANGLE LOCK LABEL
617	P0701617	GUIDE POST LOCK NOTICE
618	P0701618	WHEEL LOCK LEVER NOTICE

## WARNING

Safety labels help reduce the risk of serious injury caused by machine hazards. If any label comes off or becomes unreadable, the owner of this machine **MUST** replace it in the original location before resuming operations. For replacements, contact (800) 523-4777 or [www.grizzly.com](http://www.grizzly.com).







# WARRANTY & RETURNS

---

Grizzly Industrial, Inc. warrants every product it sells for a period of **1 year** to the original purchaser from the date of purchase. This warranty does not apply to defects due directly or indirectly to misuse, abuse, negligence, accidents, repairs or alterations or lack of maintenance. This is Grizzly's sole written warranty and any and all warranties that may be implied by law, including any merchantability or fitness, for any particular purpose, are hereby limited to the duration of this written warranty. We do not warrant or represent that the merchandise complies with the provisions of any law or acts unless the manufacturer so warrants. In no event shall Grizzly's liability under this warranty exceed the purchase price paid for the product and any legal actions brought against Grizzly shall be tried in the State of Washington, County of Whatcom.

We shall in no event be liable for death, injuries to persons or property or for incidental, contingent, special, or consequential damages arising from the use of our products.

The manufacturers reserve the right to change specifications at any time because they constantly strive to achieve better quality equipment. We make every effort to ensure that our products meet high quality and durability standards and we hope you never need to use this warranty.

In the event you need to use this warranty, contact us by mail or phone and give us all the details. We will then issue you a "Return Number," which must be clearly posted on the outside as well as the inside of the carton. We will not accept any item back without this number. Proof of purchase must accompany the merchandise.

Please feel free to write or call us if you have any questions about the machine or the manual.

Thank you again for your business and continued support. We hope to serve you again soon.

For further information about the warranty, visit <https://www.grizzly.com/forms/warranty> or scan the QR code below to be automatically directed to our warranty page.



**grizzly.com**<sup>®</sup>  
**TOOL WEBSITE**

Buy Direct and Save with Grizzly<sup>®</sup> – Trusted, Proven and a Great Value!  
~Since 1983~

*Visit Our Website Today For  
Current Specials!*

**ORDER  
24 HOURS A DAY!  
1-800-523-4777**

