



DRILL PRESS

MODEL G4008/G4009

INSTRUCTION MANUAL



COPYRIGHT © 1996 BY GRIZZLY IMPORTS, INC.

WARNING: NO PORTION OF THIS MANUAL MAY BE REPRODUCED IN ANY SHAPE OR FORM WITHOUT THE WRITTEN APPROVAL OF GRIZZLY IMPORTS, INC.

APRIL, 1997 PRINTED IN USA

DISCONTINUED MACHINE MANUAL DISCLAIMER

THE INFORMATION IN THIS MANUAL REPRESENTS THE LAST CONFIGURATION OF THE MACHINE BEFORE IT WAS DISCONTINUED. MACHINE CONFIGURATIONS MAY HAVE CHANGED AS PRODUCT IMPROVEMENTS WERE INCORPORATED. IF YOU OWN AN EARLIER VERSION OF THE MACHINE, THIS MANUAL MAY NOT EXACTLY DEPICT YOUR MACHINE. CONTACT CUSTOMER SERVICE IF YOU HAVE ANY QUESTIONS ABOUT DIFFERENCES. PREVIOUS VERSIONS ARE NOT AVAILABLE ONLINE.

WARNING

Some dust created by power sanding, sawing, grinding, drilling, and other construction activities contains chemicals known to the State of California to cause cancer, birth defects or other reproductive harm. Some examples of these chemicals are:

- Lead from lead-based paints.
- Crystalline silica from bricks, cement, and other masonry products.
- Arsenic and chromium from chemically treated lumber.

Your risk from these exposures varies, depending on how often you do this type of work. To reduce your exposure to these chemicals: work in a well ventilated area, and work with approved safety equipment, such as those dust masks that are specially designed to filter out microscopic particles.

Table Of Contents

	PAGE
1. SAFETY	2
SAFETY RULES FOR ALL TOOLS	2
ADDITIONAL SAFETY INSTRUCTIONS FOR DRILL PRESSES	3
2. CIRCUIT REQUIREMENTS	4
110V OPERATION	4
GROUNDING	4
3. GENERAL INFORMATION	5
UNPACKING	6
PIECE INVENTORY	6
CLEAN UP.....	7
SITE CONSIDERATIONS	7
4. ASSEMBLY	8
BEGINNING ASSEMBLY	8
BASE/COLUMN	8
HEADSTOCK/COLUMN	9
WORKING TABLE.....	10
MOTOR	11
MOTOR WIRING.....	11
DRILL CHUCK.....	12
5. ADJUSTMENTS	13
SPEED CHANGES	13
DEPTH STOP	13
TABLE ADJUSTMENTS	14
CHUCK REMOVAL.....	15
6. OPERATIONS	16
TEST RUN.....	16
DRILL CHANGES	16
DRILL SPEED	17
DRILLING METAL.....	17
DRILLING WOOD	18
MORTISE ATTACHMENT.....	18
7. MAINTENANCE	19
GENERAL	19
BELT TENSION.....	19
LUBRICATION	19
8. CLOSURE	20
GENERAL MACHINE DATA.....	21
PART BREAKDOWN	22
PART LIST	23
WARRANTY AND RETURNS.....	24

SECTION 1: SAFETY

WARNING: For Your Own Safety Read Instruction Manual Before Operating Drill Press

- a) Always wear eye protection.
- b) Do not wear gloves, necktie or loose clothing.
- c) Clamp workpiece or brace against the column to prevent rotation.
- d) Use recommended speed for drill accessory and workpiece material.

Safety Instructions For Power Tools

These safety rules cannot cover every situation in a work shop. Consider your conditions when setting up or operating your drill press

1. **KEEP GUARDS IN PLACE** and in working order.
2. **REMOVE ADJUSTING KEYS AND WRENCHES.** Form habit of checking to see that keys and adjusting wrenches are removed from tool before turning on.
3. **KEEP WORK AREA CLEAN.** Cluttered areas and benches invite accidents.
4. **DON'T USE IN DANGEROUS ENVIRONMENT.** Don't use power tools in damp or wet locations, or expose them to rain. Keep work area well lighted.
5. **KEEP CHILDREN AWAY.** All visitors should be kept a safe distance from work area.
6. **MAKE WORK SHOP KID PROOF** with padlocks, master switches, or by removing starter keys.
7. **DON'T FORCE TOOL.** It will do the job better and safer at the rate for which it was designed.
8. **USE RIGHT TOOL.** Don't force tool or attachment to do a job for which it was not designed.
9. **USE PROPER EXTENSION CORD.** Make sure your extension cord is in good condition. When using an extension cord, be sure it is rated Hard Service (grade S) or better. Conductor size must be 16 A.W.G. for cords up to 100 feet in length. An undersized cord will cause a drop in line voltage resulting in loss of power and overheating. Your extension cord must also contain a ground wire and plug pin. Always repair or replace extension cords if they become damaged. Minimum Gage for extension cord:

16 A.W.G.	50ft
16 A.W.G.	100ft
14 A.W.G.	200ft
12 A.W.G.	300ft
10. **WEAR PROPER APPAREL** Do not wear loose clothing, gloves, neckties, rings, bracelets, or other jewelry which may get caught in moving parts. Non-slip footwear is recommended. Wear protective hair covering to contain long hair.
11. **ALWAYS USE SAFETY GLASSES.** Also use face or dust mask if cutting operation is dusty. Everyday eyeglasses only have impact resistant lenses, they are NOT safety glasses.

12. **SECURE WORK.** Use clamps or a vise to hold work when practical. It's safer than using your hand and frees both hands to operate tool.
13. **DON'T OVERREACH.** Keep proper footing and balance at all times.
14. **MAINTAIN TOOLS WITH CARE.** Keep tools sharp and clean for best and safest performance. Follow instructions for lubricating and changing accessories.
15. **DISCONNECT TOOLS** before servicing and changing accessories, such as blades, bits, cutters, and the like.
16. **REDUCE THE RISK OF UNINTENTIONAL STARTING.** Make sure switch is in off position before plugging in.
17. **USE RECOMMENDED ACCESSORIES.** Consult the owner's manual for recommended accessories. The use of improper accessories may cause risk of injury to persons.
18. **CHECK DAMAGED PARTS.** Before further use of the tool, a guard or other part that is damaged should be carefully checked to determine that it will operate properly and perform its intended function - check for alignment of moving parts, binding of moving parts, breakage of parts, mounting, and any other conditions that may affect its operation. A guard or other part that is damaged should be properly repaired or replaced.
19. **DIRECTION OF FEED.** Feed work into a blade or cutter against the direction of rotation of the blade or cutter only.
20. **NEVER LEAVE TOOL RUNNING UNATTENDED. TURN POWER OFF.** Don't leave tool until it comes to a complete stop.

Additional Safety Instructions For Drill Presses

1. Never use a bit with a tapered shank or square bit in a drill chuck.
2. Remove metal cuttings with a brush, never by hand.
3. Never drill sheet metal unless it is securely clamped to the table.
4. Feed the drill bit evenly into the workpiece. Back the bit out of deep cuts to cool and clean the bit.
5. Never attempt to clean wood or metal cuttings from drill bits while the drill press is running.
6. Work should be secured in such a way so as to avoid drilling into the table.

SECTION 2: CIRCUIT REQUIREMENTS

110V Operation

The G4008/G4009 Drill Press is supplied with a U.S. made 110V/220V motor. Under normal use, the motor draws approximately 9 amps @ 110V. We recommend using a 15 amp circuit breaker or a 15 amp slow blow fuse for 110V operation. This should be satisfactory for normal use, while preventing motor damage from high heat caused by overload. If frequent circuit failures occur when using the drill press, contact our service department or your local electrical contractor.

220V: Contact the service department for further instruction on wiring for 220V.



Grounding

CAUTION: THIS TOOL MUST BE GROUNDED WHILE IN USE TO PROTECT THE OPERATOR FROM ELECTRIC SHOCK.

In the event of a malfunction or breakdown, grounding provides a path of least resistance for electric current to reduce the risk of electric shock. This tool is equipped with an electric cord having an equipment-grounding conductor and a grounding plug. The plug must be plugged into a matching outlet that is properly installed and grounded in accordance with all local codes and ordinances.

Improper connections of the electrical-grounding conductor can result in risk of electric shock. The conductor with green or green and yellow striped insulation is the electrical-grounding conductor. If repair or replacement of the electric cord or plug is necessary, do not connect the equipment grounding conductor to a live terminal.

Under no circumstances should the grounding pin from any three-pronged plug be removed. If it will not fit the outlet, have the proper outlet installed by a qualified electrician.

Check with a qualified electrician or one of our service personnel if the grounding instructions are not completely understood, or if in doubt as to whether the tool is properly grounded. Use only 3-wire extension cords that have 3-prong grounding type plugs and 3-hole receptacles that accept the tool's plug. **Figure 1.**

Repair or replace damaged or worn cord immediately.

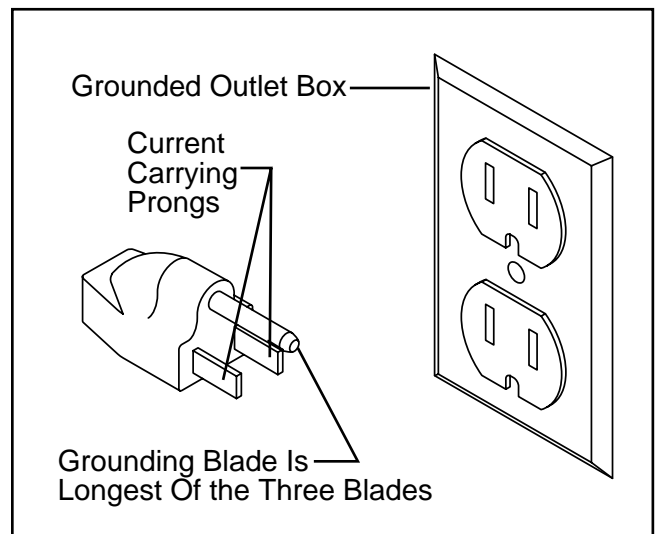

Figure 1.



SECTION 3: GENERAL INFORMATION

Grizzly Imports, Inc. is proud to offer the Model G4008/G4009 Drill Press. This drill press is a part of Grizzly's growing family of fine woodworking and metalworking machinery. When used according to the guidelines stated in this manual, you can expect years of trouble-free, enjoyable operation.

The Model G4008/G4009 is intended for home and medium-duty professional use. This drill press features a 1,725 R.P.M., ½ H.P. capacitor-start motor, mechanical ON/OFF switch and a cast iron working table.

All running parts utilize shielded ball bearings, which require no lubrication for the life of the bearings.

We are also pleased to provide this manual with the Model G4008/G4009. It was written to guide you through assembly, review safety considerations, and cover general operating procedures. It represents our latest effort to produce the best documentation possible. If you have any criticisms that you feel we should pay attention to in our next printing, please write to us at the Bellingham, WA address at the end of this section.

Most important, we stand behind our machines. We have an excellent service department at your disposal should the need arise. If you have any service questions or parts requests, please call or write to us at the location listed below.

Grizzly Industrial, Inc.
1203 Lycoming Mall Circle
Muncy, PA 17756
Phone:(570) 546-9663
Fax:(800) 438-5901
E-Mail: techsupport@grizzly.com
Web Site: <http://www.grizzly.com>

To comment on this manual write to:

Grizzly Industrial, Inc.
% Technical Documentation
P.O. Box 2069
Bellingham, WA 98227

To operate this or any power tool safely and efficiently, it is essential to become as familiar with it as possible. The time you invest before you begin to use your Model G4008/G4009 will be time well spent. **DO NOT** operate this machine until you are completely familiar with the contents of this manual.

Unpacking

The Model G4008/G4009 Drill press is shipped from the manufacturer in a carefully packed carton. If you discover the machine is damaged after you've signed for delivery, *please call Customer Service immediately for advice.*

Save the containers and all packing materials for possible inspection by the carrier or its agent. *Otherwise filing a freight claim can be difficult.*

Caution: The G4008/G4009 is a heavy machine (G4008-155 lbs. shipping weight; G4009-205 lbs. shipping weight). **DO NOT** over-exert yourself while unpacking or moving your machine – get assistance. In the event that your drill press must be moved up or down a flight of stairs, be sure that the stairs are capable of supporting the combined weight of people and the machine.

When you are completely satisfied with the condition of your shipment, you should inventory its parts.



Piece Inventory

After all the parts have been removed from the carton, you should have:

- Working Table
- Column (Separate box for G4009)
- Base
- Headstock Assembly
- Motor (Separate Box)
- Motor Pulley
- Crank Handle
- Column Lock Handle
- Table Bracket
- Working Table
- Handle Bar (3)
- Hex Bolt M10 - 1.5 x 40mm (4)
- Lock Washers 10mm
- Cap Screw M16-2.0 x 40
- Wedge Shifter
- Chuck Key
- Drill Chuck
- Drill Chuck Arbor
- 4 & 12mm Allen Wrenches

In the event that any non-proprietary parts are missing (e.g. a nut or a washer), we would be glad to replace them, or, for the sake of expediency, replacements can be obtained at your local hardware store.



Figure 2. Overview of all the parts.

Clean up

The column and other unpainted parts of the Model G4008/G4009 are coated with a waxy oil that protects them from corrosion during shipment. Remove the protective coating with mineral spirits and paper towels. Do not use gasoline or other petroleum based solvents because of their extremely low flash points. Do not use chlorine-based solvents – if you happen to splash some onto a painted surface, you'll ruin the finish.

WARNING!

Follow the safety rules listed below when working with solvents:

1. Read and follow all directions and warnings on the solvent label.
2. Work only in a well ventilated area.
3. Do not work near any type of open flame (e.g., pilot lights, kerosene heaters, and so on).
4. **DO NOT** smoke while working with flammable material.
5. Paper towels from the cleaning process are extremely combustible. Dispose of waste towels so they do not create a fire hazard.



Site Considerations

1. **Floor Load:** Your G4008/G4009 Drill press represents a large weight load in a small footprint. Most commercial floors are suitable for the Model G4008/G4009. Some residential floors may require additional build-up to support both machine and operator.
2. **Working Clearances:** Consider existing and anticipated needs, size of material to be processed through each machine, and space for auxiliary stands, work tables or other machinery when establishing a home for your drill press. Allow sufficient room to safely run your machines in any foreseeable operation.
3. **Lighting and Outlets:** Lighting should be bright enough to eliminate shadow and prevent eye strain. Electrical circuits should be dedicated or large enough to handle amperage requirements. Outlets should be located near each machine so power or extension cords are clear of high-traffic areas. Observe local electrical codes for proper installation of new lighting, outlets, or circuits.



SECTION 2: ASSEMBLY

Beginning Assembly

Most of the Drill Press has been pre-assembled at the factory. The few remaining pieces should go together quickly and easily. This manual is written for both the G4008 and G4009. The only difference between the two regarding assembly is the length of the column.

CAUTION: All die-cut metal parts have a sharp edge (called “flashing”) on them after they are formed. This is removed at the factory. Sometimes though, a bit of flashing might escape inspection. Please examine the edges of all die-cut metal parts before handling them.

Tools Required: Only a few common tools are needed to assemble this machine. Specifically, a 14mm open end wrench, Phillips screwdriver and 3mm and 4mm Allen wrench.



Base/Column

1. Place the base on the floor (if G4009) or on a suitable bench (if G4008). In either case, be sure the surface is flat and stable.
2. Place the column onto the base, line up the four holes and secure with the four M10-1.5 x 40mm Hex Head Bolts and lock washers provided. **Figure 3.**



Figure 3.



Headstock/Column

1. Place the Headstock assembly onto the top of the column and lower it until it is seated on the column as far as it will go. **CAUTION:** The head assembly is quite heavy; get assistance when lifting.
2. Rotate the headstock until it lines up with the base.
3. Secure the headstock to the column by tightening the setscrews located on the side. **Figure 4.**



Figure 4.

4. Screw the three handle bars into the tapped holes in the handle body. **Figure 9.**



Figure 5.



Working Table

1. Place the crank handle onto the raise/lower shaft and tighten down. **Figure 6.**

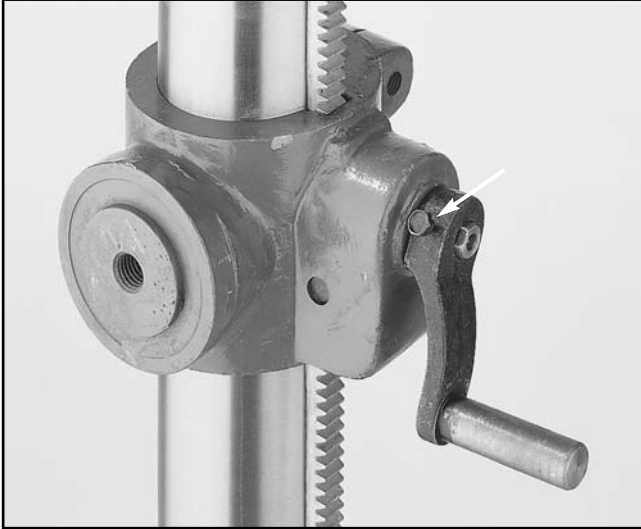

Figure 6.

2. Insert the M16-2.0 x 40 cap screw through the hole located on the bottom/rear of the table bracket.
3. Thread the cap screw into the column bracket and tighten down. **Figure 7.**



Figure 7.

4. Place the table into the hole in the table bracket and secure with the table lock handle. **Figure 8.**

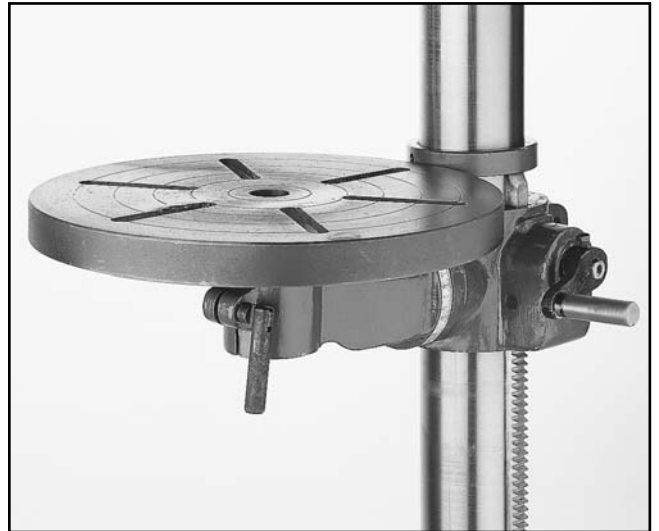

Figure 8.

5. Thread the column lock handle into the column bracket. Leave the lock handle loose for now. **Figure 9.**



Figure 9.



Motor

1. Remove the motor mount bolts from the motor mount.
2. You will need help for this step: Attach the motor to the motor mount using the hardware removed in **Step 1**. Lightly tighten down the bolts.
3. Slide the motor pulley onto the motor shaft lining up the setscrew with the flat spot on the motor shaft. Tighten the setscrew.
4. Install the V-Belt and adjust the motor as necessary so the pulleys line up correctly. **Figure 10.**



Figure 10.



Motor Wiring

1. Remove the wire box cover located at the end of the motor.
2. Wire the motor per the diagram in **Figure 11.**

NOTE: The wires from the switch, besides the ground wire, are interchangeable; therefore their colors are not specified.

3. Attach the ground wire securely to the green screw located on the back of the motor.
4. Attach motor wire cover.
5. If the motor runs backwards, reverse the positions of motor wires #5 and #8.

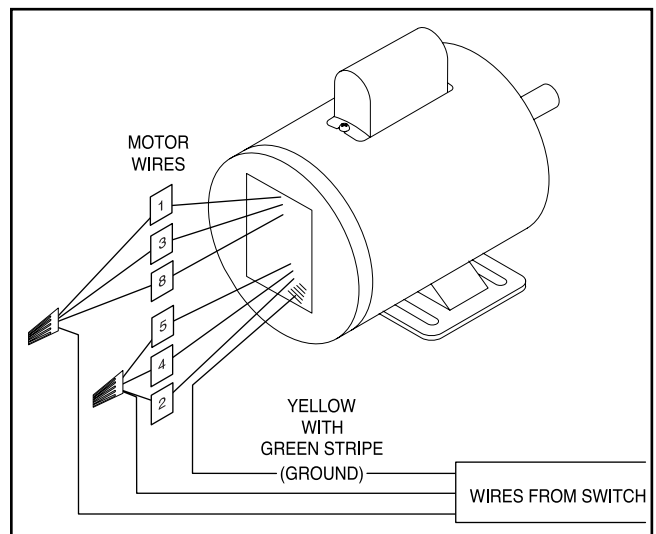

Figure 11.



Drill Chuck

To mount the drill chuck on the drill press:

1. Thoroughly clean all of the oil from both ends of the arbor, inside the drill chuck and the drill press spindle.
2. The short taper on the end of the drill chuck arbor is called a 'Jacobs Taper'. In this case, a 'Jacobs Taper #3'. Slide the short taper into the drill chuck and tap lightly with a soft hammer or block of wood.

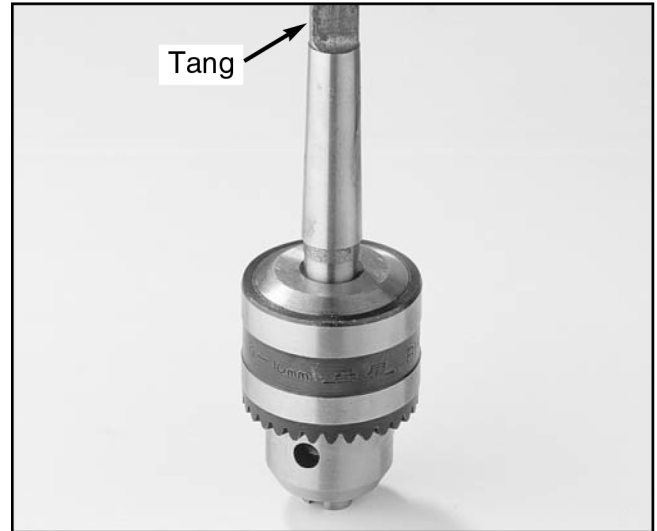

Figure 12.

3. The long taper of the drill chuck arbor is called a 'Morse Taper'. In this case, a 'Morse Taper #2'. Slide the arbor and chuck into the drill press spindle and turn it until the *tang* slips into the slot in the spindle.
4. While holding onto the drill chuck, tap lightly on the bottom of the chuck with a soft hammer or a block of wood. The drill chuck should now be quite snug in the drill press. If not, repeat steps 1-3, making sure all oil is removed.



SECTION 5: ADJUSTMENTS

Speed Change

Remember to disconnect the drill press from the power source before attempting any adjustments.

1. Loosen the two lock knobs, one on either side of the head. **Figure 13.**
2. Turn the cam lever so the motor pulley moves toward the center pulley. **Figure 13.**
3. Select the desired speed. Open the top cover and move the belts into the corresponding position for the selected speed.
4. Rotate the cam lever so the motor pulley moves away from the center pulley and tighten locking screws on both sides of the head.

CAUTION: Never run the drill press with the cover open.



Figure 13.



Depth Stop

To stop the vertical travel of the drill bit at a desired depth, loosen the scale set knob located on the feed shaft assembly, rotate the collar to the desired depth and tighten the scale set knob. **Figure 14.**

To hold a stationary depth, loosen the scale set knob and rotate the feed shaft to the desired depth. Then, rotate the collar clockwise until it stops and tighten the scale set knob. This will lock the spindle at the desired depth.



Figure 14.



Table Adjustments

1. To adjust the table up or down, loosen the column lock handle and turn the crank handle to the desired height. Tighten the column lock handle. **Figure 15.**

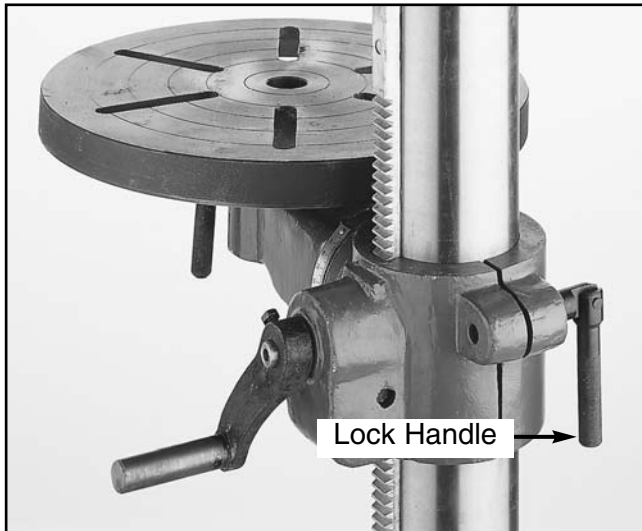

Figure 15.

2. To swing the table, loosen the column lock handle and swing the table to the desired position. Tighten the column lock handle. For long workpieces, swing the work table away 180° and use the base as your table.
3. To rotate the table, loosen the table lock handle, rotate the table to the desired position and tighten the table lock handle. **Figure 16.**

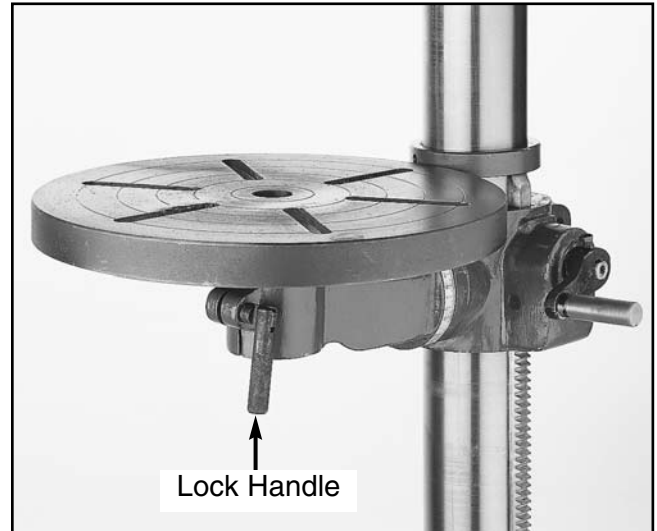

Figure 16.

4. To tilt the table, loosen the pivot bolt with the 12mm Allen wrench supplied. **Figure 17.** Tilt the table to the desired angle (up to 45°). Tighten the pivot bolt.

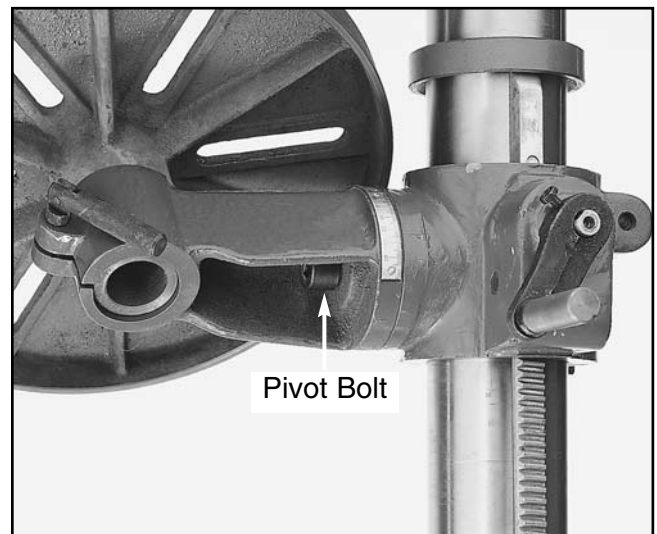

Figure 17.



Chuck Removal

1. Adjust the stationary depth to three inches (see depth setting instructions).
2. Rotate the spindle manually and line up the internal spindle slot with the slot on the side of the quill. The end of the drill chuck (the tang) should be visible through the slot at this point.
3. Insert the wedge shifter through the slot in the spindle with the tapered edge facing down. **Figure 18.**
4. When the tapered edge of the wedge shifter contacts the top of the taper, tap the wedge shifter lightly with a hammer until the taper and chuck are loose. Do not allow the taper and chuck to fall onto the table.



Figure 18.



SECTION 6: OPERATIONS

Test Run

Once the assembly is complete and the adjustments are done to your satisfaction, you are ready to test the machine.

Turn on the power supply at the main panel. Press the START button. Make sure that your finger is poised on the STOP button, just in case there's a problem. The drill press should run smoothly, with little or no vibration or rubbing noises. Strange or unnatural noises should be investigated and corrected before operating the machine further.

WARNING: *DO NOT attempt to investigate or adjust the machine while it is running. Wait until the machine is turned off, unplugged and all working parts have come to a rest before you do anything!*



Drill Changes

To insert or change a bit, care must be taken to secure the bit firmly in place. When changing bits, proceed as follows:

1. Disconnect the machine from the power source.
2. Open the chuck wide enough to accept the bit.
3. Install the bit so the chuck jaws will grab the major portion of the bit shank. Do not allow the chuck to grab the fluted body of the drill bit.
4. Tighten the chuck with the chuck key using all three key locations.
5. Remove the chuck key and reconnect to the power source.
6. Reverse steps to remove drill bit.



Drill Speed

The best speed to use in any drill press operation is determined by; material, size of drill bit, type of drill bit or cutter and quality of cut desired. The smaller the drill bit, the greater the speed. In soft materials, the speed should be higher than for hard materials. Refer to the chart below.



Drilling Metal

When drilling metal, use clamps to hold the workpiece securely in place. The workpiece should never be held in place by bare hands. The cutting edge can catch in the material at any time, resulting in serious injury. Any movement of the workpiece during the drilling operation may result in a rough or misplaced hole and increase the chance of drill bit breakage.

For flat work, lay the workpiece on a wooden base and clamp it firmly to the table. Use a V-block and clamp for round stock. A drill press vise with prismatic jaws can also be used to hold flat or round material.



Recommended RPM				
<u>Drill Diameter</u>	<u>Cast Iron</u>	<u>Steel</u>	<u>Aluminum</u>	<u>Wood</u>
1/8"	1900	2620	2620	2620
3/16"	1550	1620	2620	2620
1/4"	990	1350	1550	2620
5/16"	650	990	1550	1550
3/8"	600	990	990	1550
7/16"	510	650	990	990
1/2"	510	650	650	990
9/16"	390	600	650	990
5/8"	390	510	510	650
3/4"	340	390	510	350
7/8"	250	340	390	510
1"	—	340	390	510
1 1/8"	—	250	340	390
1 1/4"	—	—	340	390

Drilling Wood

Twist bits, which are intended for metal, may also be used for boring holes in wood. Machine spur bits are generally preferred, they cut a square bottomed hole and are designed for removal of wood chips. Do not use hand bits which have a screw tip; at drill press speeds they turn into the wood too fast and tend to lift the workpiece off the table and spin it.

For through boring, line up the hole in the work table with the bit to avoid damaging its tip. Scribe a vertical line on the column and a matching line on the table bracket so the table can be clamped in the center position at any height. Use a piece of scrap wood under your workpiece and feed the bit into the wood slowly to prevent splintering the bottom side of the workpiece.

When using your drill press for operations such as shaping, sanding or mortising, use jigs, fixtures or hold-downs that are appropriate. For more information, review reference materials pertaining to your specific application.

The chuck will accept any tool with up to a $\frac{5}{8}$ " shank. Do not attempt to open the chuck wider by forcing it.



Mortise Attachment

The optional Grizzly G1083 Mortise Attachment was specifically designed to fit the G4008/G4009 Drill Press. Refer to our current catalog for ordering information.

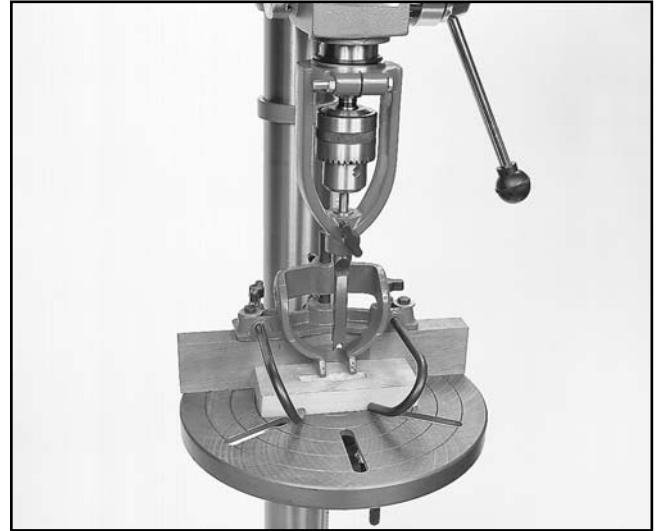

Figure 19.



SECTION 7: MAINTENANCE

General

Make a habit of inspecting your drill press each time you use it. Check for the following conditions and repair or replace when necessary.

1. Loose mounting bolts.
2. Worn switch.
3. Worn or damaged cords and plugs.
4. Damaged V-belt.
5. Any other condition that could hamper the safe operation of this machine.



Belt Tension

Proper belt tension is achieved by tightening the belt adjusting cam so the belt has a slight tension on it. Excessive tension will create heat and shorten belt life. Too little tension will cause the belt to slip and squeal.



Lubrication

Shielded and pre-lubricated ball bearings require no lubrication for the life of the bearings. In a continuous-use environment, expect the bearings to last for several years. With intermittent use, bearings can be expected to last much longer. All bearings are standard sizes and can be easily replaced.

For other items on this machine, such as the quill (ref. #56 in the part breakdown), table and column, an occasional shot of light machine oil is all that is necessary. Before applying lubricant, clean off sawdust and metal chips. Use a light grease on the rack, both on the teeth and between the rack and column.

The goal is to achieve adequate lubrication. Too much lubricant will attract dirt and sawdust, and clog the drill press mechanism.



SECTION 8: CLOSURE

The following pages contain parts diagram, parts list, general machine data, troubleshooting guide and Warranty/Return information for your Model G4008/G4009 Drill Press.

If you need parts or help in assembling your machine, or if you need operational information, we encourage you to call our Service Department. Our trained service technicians will be glad to help you.

If you have comments dealing specifically with this manual, please write to our Bellingham, Washington location using the address in the Introduction. The specifications, drawings, and photographs illustrated in this manual represent the Model G4008/G4009 as supplied when the manual was prepared. However, due to Grizzly's policy of continuous improvement, changes may be made at any time with no obligation on the part of Grizzly. Whenever possible, though, we send manual updates to all owners of a particular tool or machine. Should you receive one, add the new information to this manual and keep it for reference.

We have included some important safety measures that are essential to this machine's operation. While most safety measures are generally universal, Grizzly reminds you that each workshop is different and safety rules should be considered as *they apply to your specific situation*.

We recommend you keep a copy of our current catalog for complete information regarding Grizzly's warranty and return policy. If you need additional technical information relating to this machine, or if you need general assistance or replacement parts, please contact our Service Department listed in the introduction.

Additional information sources are necessary to realize the full potential of this machine. Trade journals, woodworking magazines, and your local library are good places to start.

WARNING!

Like all power tools, there is danger associated with the Model G4008/G4009 Drill press. Use the tool with respect and caution to lessen the possibility of mechanical damage or operator injury. If normal safety precautions are overlooked or ignored, injury to the operator or others in the area is likely.

The Model G4008/G4009 was specifically designed for drilling operations. **DO NOT MODIFY AND/OR USE THIS DRILL PRESS FOR ANY OTHER PURPOSE. Modifications or improper use of this tool will void the warranty.** If you are confused about any aspect of this machine, **DO NOT** use it until you have answered all your questions.

GENERAL MACHINE DATA

Design Type Bench Model/Floor Model

Overall Dimensions:

Table Size 12 ½"
Overall Height 40"/64"
Overall Width 14"
Overall Depth 27"
Weight (Net) 145 lbs./195 lbs.

Construction:

Table Cast Iron
Column Steel Tube
Base and Head Cast Iron

Motor:

Type TEFC Capacitor Start
Horsepower ½ HP
Phase/Cycle Single Phase/60Hz
Voltage 110V
Amps 4.2
RPM 1720
Bearings Sealed & Lubricated For Life

Capacities:

Spindle Travel 3¾"
Max. Spindle-to-base 18"/44"
Max. Spindle-to-table 16½"/38½"
Morse Taper #2
Spindle Taper JT 3
Swing 6⅞"
Chuck Size ⅝"
Speeds 210, 305, 340, 460, 500, 560, 1030, 1240, 1305, 1720, 1970, 2720
Quill Diameter 52mm
Maximum Drill Capacity ¾"

Features:

Table Tilt 0°-45° Left and Right
Table Swing 360°
Drive Four Step Pulley
Table Locks Positive
Table Height Adjustment Worm Gear

Specifications, while deemed accurate, are not guaranteed.

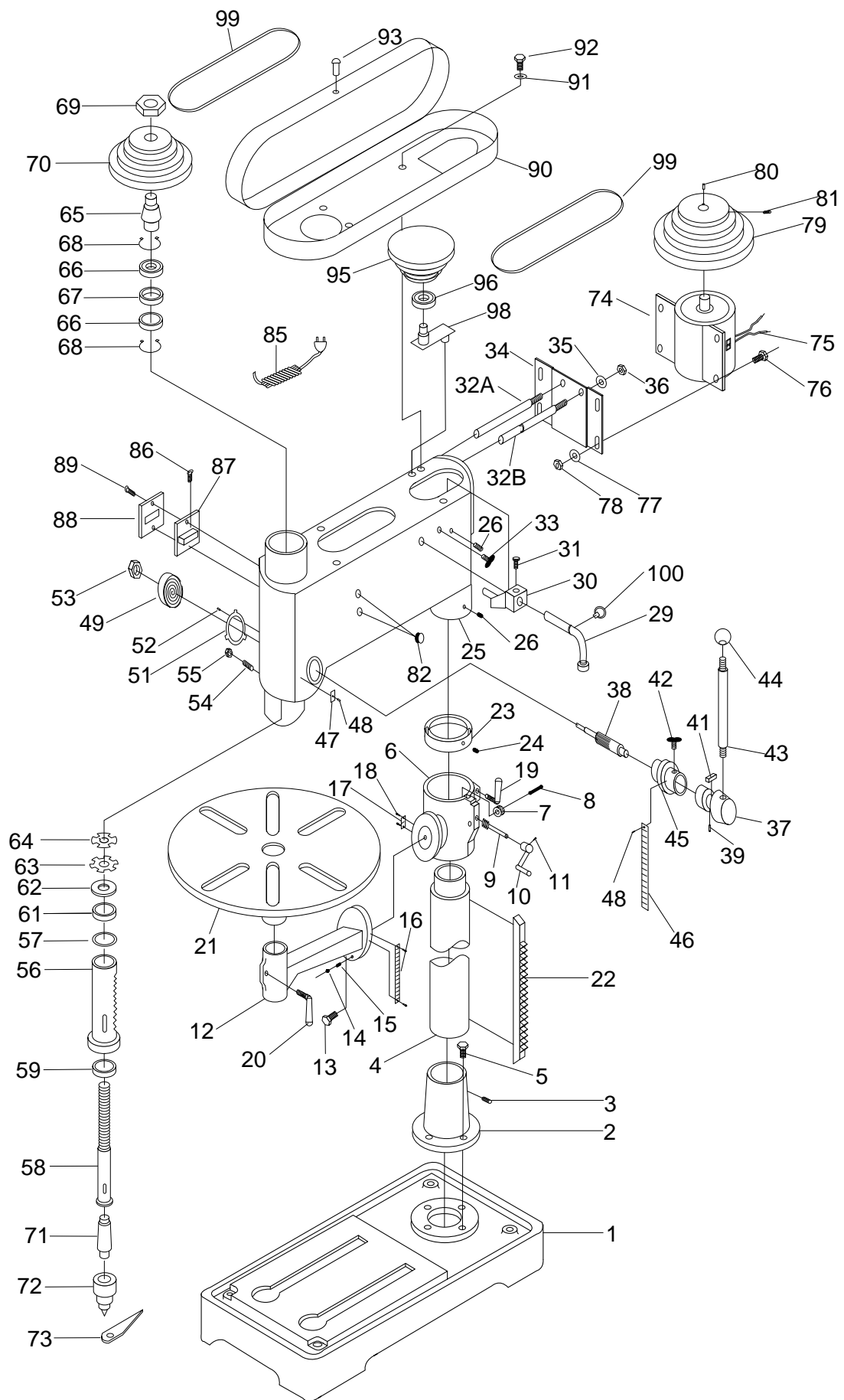

REF	PART #	DESCRIPTION
1	P4008001	BASE
2	P4008002	COLUMN HOLDER
3	P4008003	SET SCREW
4	P4008004	COLUMN
5	PB31M	HEX BOLT
6	P4008006	BRACKET
7	P4008007	PINION GEAR
8	P4008008	GEAR SHAFT
9	P4008009	WORM PINION
10	P4008010	CRANK HANDLE
11	P4008011	HEX BOLT
12	P4008012	TABLE BRACKET
13	P4008013	HEX BOLT
16	P4008016	ANGLE SCALE
17	P4008017	CENTERING SCALE
18	P4008018	RIVET
19	P4008019	COLUMN LOCK HANDLE
20	P4008020	TABLE LOCK HANDLE
21	P4008021	TABLE
22	P4008022	RACK
23	P4008023	RACK RING
24	P4008024	SET SCREW
25	P4008025	HEAD CASTING
26	P4008026	SET SCREW
28	P4008028	HEX BOLT
29	P4008029	CAM HANDLE
30	P4008030	CAM
31	P4008031	HEX BOLT
32	P4008032	SLIDE BAR
33	P4008033	SLIDE BAR BOLT
34	P4008034	MOTOR BASE
35	P4008035	LOCK WASHER
36	P4008036	HEX NUT
37	P4008037	HANDLE BODY
38	P4008038	FEED SHAFT
39	P4008039	FEED SHAFT SET PIN
40	P4008040	SCALE SET PIN
41	P4008041	SCALE GUIDE
42	P4008042	SLIDE BAR BOLT
43	P4008043	HANDLE BAR
44	P4008044	KNOB
45	P4008045	SPINDLE DEPTH
46	P4008046	SCALE
47	P4008047	SCALE
48	P4008048	RIVET
49	P4008049	SPRING & HOUSING
51	P4008051	SPRING SEAT
52	P4008052	SPECIAL SET SCREW
53	P4008053	HEX NUT
54	P4008054	SPECIAL SET SCREW

REF	PART #	DESCRIPTION
55	P4008055	HEX NUT
56	P4008056	QUILL
57	P4008057	RUBBER WASHER
58	P4008058	SPINDLE SHAFT
59	P4008059	BEARING
60	P4008060	NAME PLATE
61	P4008061	BEARING
62	P4008062	SPECIAL WASHER
63	P4008063	SPECIAL LOCK NUT
64	P4008064	SPECIAL NUT
65	P4008065	DRIVE SLEEVE
66	P4008066	BEARING
67	P4008067	COLLAR
68	P4008068	SPECIAL SNAP RING
69	P4008069	HEX NUT
70	P4008070	PULLEY
71	G1676	ARBOR
72	G1650	CHUCK
72A	P4008072A	1/2" CHUCK KEY
73	P4008073	WEDGE SHIFTER
74	P4008074	MOTOR
75	P4008075	WIRE
76	P4008076	HEX BOLT
77	P4008077	FLAT WASHER
78	P4008078	HEX NUT
79	P4008079	MOTOR PULLEY
80	P4008080	KEY
81	P4008081	SET SCREW
82	P4008082	WIRE INSULATOR
83	P4008083	WIRE CLIP
84	P4008084	CLIP SCREW
85	P4008085	CORD
86	P4008086	CLIP TERMINAL
87	P4008087	SWITCH
88	P4008088	SWITCH COVER
89	P4008089	SCREW
90	P4008090	PULLEY COVER
91	P4008091	FLAT WASHER
92	P4008092	SCREW
93	P4008093	COVER KNOB
95	P4008095	CENTER PULLEY
96	P4008096	BEARING
98	P4008098	CENTER PULLEY SHAFT
99	P4008099	V-BELT M26 3L260
100	P4008100	SNAP RING
--G4009 SPECIAL PARTS--		
01	P4009001	BASE
02	P4009002	COLUMN HOLDER
04	P4009004	COLUMN

WARRANTY AND RETURNS

Grizzly Imports, Inc. warrants every product it sells for a period of **1 year** to the original purchaser from the date of purchase. This warranty does not apply to defects due directly or indirectly to misuse, abuse, negligence, accidents, repairs or alterations or lack of maintenance. This is Grizzly's sole written warranty and any and all warranties that may be implied by law, including any merchantability or fitness, for any particular purpose, are hereby limited to the duration of this written warranty. We do not warrant or represent that the merchandise complies with the provisions of any law or acts unless the manufacturer so warrants. In no event shall Grizzly's liability under this warranty exceed the purchase price paid for the product and any legal actions brought against Grizzly shall be tried in the State of Washington, County of Whatcom.

We shall in no event be liable for death, injuries to persons or property or for incidental, contingent, special, or consequential damages arising from the use of our products.

To take advantage of this warranty, contact us by mail or phone and give us all the details. We will then issue you a "Return Number", which must be clearly posted on the outside as well as the inside of the carton. We will not accept any item back without this number. Proof of purchase must accompany the merchandise.

The manufacturers reserve the right to change specifications at any time because they constantly strive to achieve better quality equipment. We make every effort to ensure that our products meet high quality and durability standards and we hope you never need to use this warranty.

Please feel free to write or call us if you have any questions about the machine or the manual.

Thank you again for your business and continued support. We hope to serve you again soon.