

# READ THIS FIRST



Model G4181 / G7873  
**\*\*\*IMPORTANT UPDATE\*\*\***  
For Machines Mfd. Since 8/15  
and Owner's Manual Printed 4/14

For questions or help with this product contact Tech Support at (570) 546-9663 or [techsupport@grizzly.com](mailto:techsupport@grizzly.com)

The following change was recently made to this machine since the owner's manual was printed:

- Changed column on guide stand.

Aside from this information, all other content in the owner's manual applies and **MUST** be read and understood for your own safety. **IMPORTANT: Keep this update with the owner's manual for future reference.**

For questions or help, contact our Tech Support at (570) 546-9663 or [techsupport@grizzly.com](mailto:techsupport@grizzly.com).

## Revised Column Guide Parts

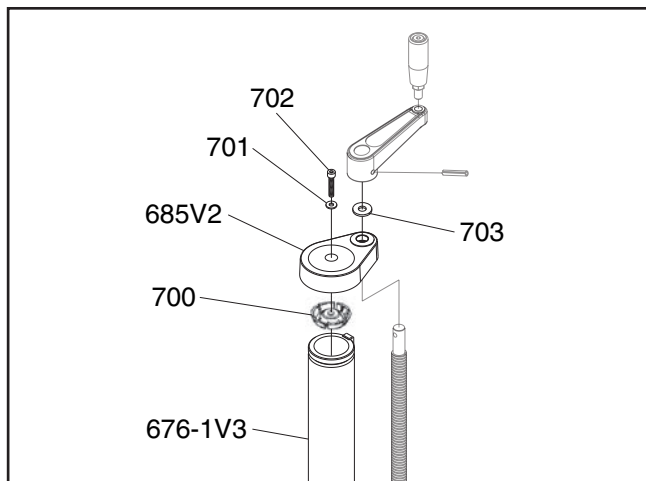

REF	PART #	DESCRIPTION
676-1V3	P4181676-1V3	VERTICAL COLUMN 560MM V3.08.15
685V2	P4181685V2	COLUMN CAP V2.08.15
700	P4181700	ANCHOR FINNED M8-1.25
701	P4181701	FLAT WASHER 8MM
702	P4181702	CAP SCREW M8-1.25 X 25
703	P4181703	FLAT WASHER 15MM

COPYRIGHT © NOVEMBER, 2015 BY GRIZZLY INDUSTRIAL, INC.  
**WARNING: NO PORTION OF THIS MANUAL MAY BE REPRODUCED IN ANY SHAPE  
OR FORM WITHOUT THE WRITTEN APPROVAL OF GRIZZLY INDUSTRIAL, INC.**  
#MN17832 PRINTED IN TAIWAN

# *Grizzly* *Industrial, Inc.*®

## MODEL G4181/G7873 1-HP POWER FEEDER

### OWNER'S MANUAL

*(For models manufactured since 12/13)*

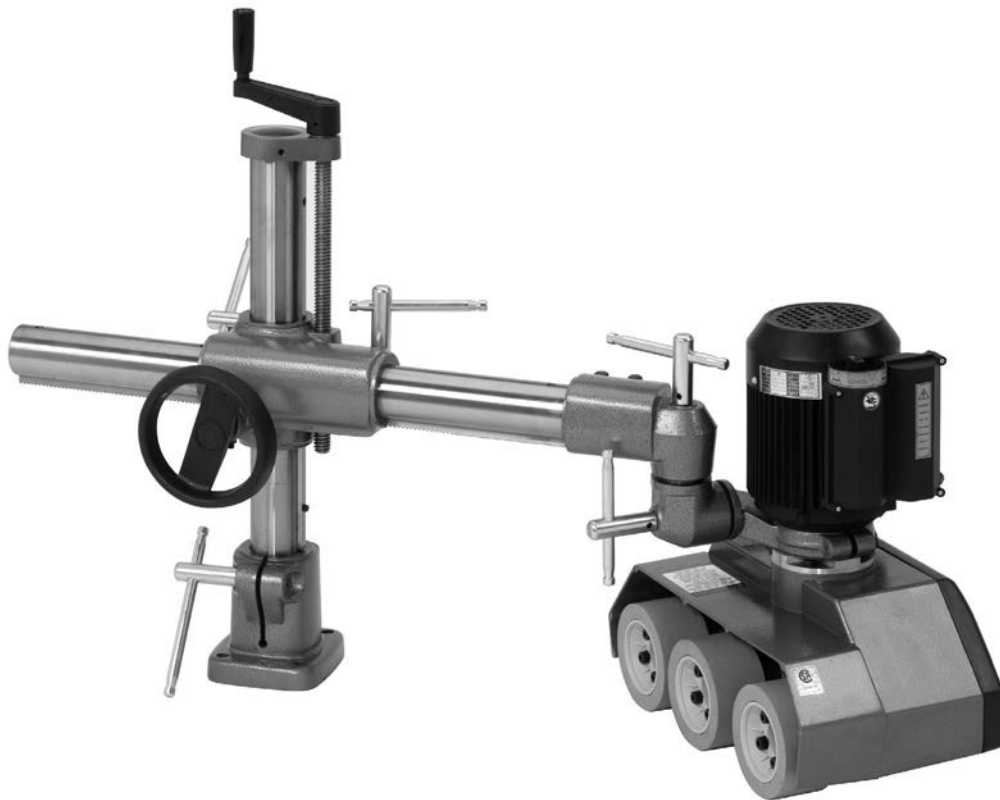

  
C US  
LR109179

COPYRIGHT © JULY, 2008 BY GRIZZLY INDUSTRIAL, INC. REVISED APRIL, 2014 (TS)  
**WARNING: NO PORTION OF THIS MANUAL MAY BE REPRODUCED IN ANY SHAPE  
OR FORM WITHOUT THE WRITTEN APPROVAL OF GRIZZLY INDUSTRIAL, INC.**

#CR10817 PRINTED IN TAIWAN

V2.04.14



## **WARNING!**

**This manual provides critical safety instructions on the proper setup, operation, maintenance, and service of this machine/tool. Save this document, refer to it often, and use it to instruct other operators.**

**Failure to read, understand and follow the instructions in this manual may result in fire or serious personal injury—including amputation, electrocution, or death.**

**The owner of this machine/tool is solely responsible for its safe use. This responsibility includes but is not limited to proper installation in a safe environment, personnel training and usage authorization, proper inspection and maintenance, manual availability and comprehension, application of safety devices, cutting/sanding/grinding tool integrity, and the usage of personal protective equipment.**

**The manufacturer will not be held liable for injury or property damage from negligence, improper training, machine modifications or misuse.**



## **WARNING!**

**Some dust created by power sanding, sawing, grinding, drilling, and other construction activities contains chemicals known to the State of California to cause cancer, birth defects or other reproductive harm. Some examples of these chemicals are:**

- **Lead from lead-based paints.**
- **Crystalline silica from bricks, cement and other masonry products.**
- **Arsenic and chromium from chemically-treated lumber.**

**Your risk from these exposures varies, depending on how often you do this type of work. To reduce your exposure to these chemicals: Work in a well ventilated area, and work with approved safety equipment, such as those dust masks that are specially designed to filter out microscopic particles.**

# Table of Contents

<b>INTRODUCTION</b> .....	<b>2</b>	<b>SECTION 4: OPERATIONS</b> .....	<b>20</b>
Manual Accuracy .....	2	Basic Use and Care.....	20
Contact Info.....	2	Changing Feed Speed.....	21
Machine Data Sheet (G4181).....	3	<b>SECTION 5: MAINTENANCE</b> .....	<b>22</b>
Machine Data Sheet (G7873).....	5	Schedule .....	22
Components & Terminology .....	7	Cleaning.....	22
<b>SECTION 1: SAFETY</b> .....	<b>8</b>	Lubrication .....	22
Safety Instructions for Machinery .....	8	<b>SECTION 6: ACCESSORIES</b> .....	<b>23</b>
Additional Safety for Power Feeders .....	10	<b>SECTION 7: SERVICE</b> .....	<b>24</b>
<b>SECTION 2: POWER SUPPLY</b> .....	<b>11</b>	Troubleshooting .....	24
<b>SECTION 3: SETUP</b> .....	<b>13</b>	Wheel Replacement.....	25
Unpacking .....	13	G4181 Wiring Diagram .....	26
Needed for Setup.....	13	G7873 Wiring Diagram .....	27
Inventory .....	14	<b>SECTION 8: PARTS</b> .....	<b>28</b>
Cleanup.....	15	Main Breakdown .....	28
Assembly .....	16	Base Breakdown.....	30
Base Mounting.....	17	<b>WARRANTY &amp; RETURNS</b> .....	<b>33</b>
Mounting Options.....	18		
Test Run .....	19		



# INTRODUCTION

## Manual Accuracy

We are proud to provide a high-quality owner's manual with your new machine!

We made every effort to be exact with the instructions, specifications, drawings, and photographs in this manual. Sometimes we make mistakes, but our policy of continuous improvement also means that **sometimes the machine you receive is slightly different than shown in the manual.**

If you find this to be the case, and the difference between the manual and machine leaves you confused or unsure about something, check our website for an updated version. We post current manuals and manual updates for free on our website at **www.grizzly.com.**

Alternatively, you can call our Technical Support for help. Before calling, make sure you write down the **Manufacture Date** and **Serial Number** from the machine ID label (see below). This information is required for us to provide proper tech support, and it helps us determine if updated documentation is available for your machine.

## Contact Info

We stand behind our machines! If you have questions or need help, contact us with the information below. Before contacting, make sure you get the **serial number** and **manufacture date** from the machine ID label. This will help us help you faster.

Grizzly Technical Support  
1815 W. Battlefield  
Springfield, MO 65807  
Phone: (570) 546-9663  
Email: techsupport@grizzly.com

We want your feedback on this manual. What did you like about it? Where could it be improved? Please take a few minutes to give us feedback.

Grizzly Documentation Manager  
P.O. Box 2069  
Bellingham, WA 98227-2069  
Email: manuals@grizzly.com

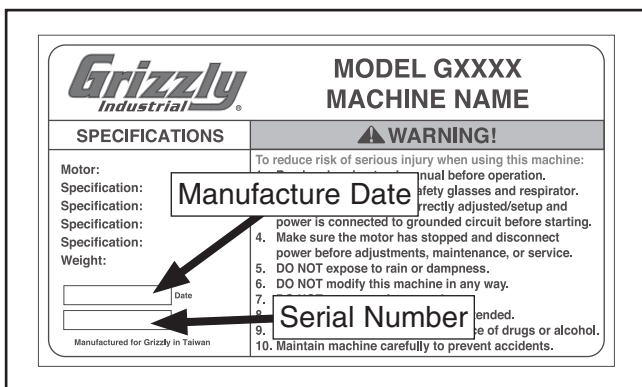



# MACHINE DATA SHEET

Customer Service #: (570) 546-9663 · To Order Call: (800) 523-4777 · Fax #: (800) 438-5901

## MODEL G4181 1 HP POWER FEEDER

### Product Dimensions:

Weight..... 130 lbs.  
 Width (side-to-side) x Depth (front-to-back) x Height..... 44 x 16 x 30 in.  
 Footprint (Length x Width)..... N/A x N/A

### Shipping Dimensions:

#### Carton #1

Type..... Cardboard Box  
 Content..... Machine  
 Weight..... 60 lbs.  
 Length x Width x Height..... 21 x 12 x 22 in.  
 Must Ship Upright..... No

#### Carton #2

Type..... Cardboard Box  
 Content..... Stand  
 Weight..... 81 lbs.  
 Length x Width x Height..... 30 x 13 x 12 in.  
 Must Ship Upright..... No

### Electrical:

Power Requirement..... 240V, Single-Phase, 60 Hz  
 Full-Load Current Rating..... 4.2A  
 Minimum Circuit Size..... 15A  
 Connection Type..... Cord & Plug  
 Power Cord Included..... Yes  
 Power Cord Length..... 9 ft.  
 Power Cord Gauge..... 16 AWG  
 Plug Included..... Yes  
 Included Plug Type..... 6-15  
 Switch Type..... Forward/Reverse Switch with 2 Speeds

### Motors:

#### Main

Type..... TEFC Capacitor-Start Induction  
 Horsepower..... 1 HP  
 Phase..... Single-Phase  
 Amps..... 4.2A/2.5A  
 Speed..... 3210 / 1700 RPM  
 Power Transfer ..... Gear Drive  
 Bearings..... Sealed & Permanently Lubricated

### Main Specifications:

#### Workpiece Capacities

Minimum Workpiece Length..... 7 in.



**Operation Info**

Number of Feed Speeds..... 4  
 Feed Speeds..... 13, 26, 33, 66 FPM  
 Swing..... 360 deg.  
 Vertical Movement..... 9 in.  
 Horizontal Movement..... 17 in.  
 Rotation..... Forward, Reverse

**Roller Info**

Number of Rollers..... 3  
 Roller Width..... 2-1/4 in.  
 Roller Diameter..... 4-5/8 in.  
 Roller Suspension..... 3/4 in.  
 Maximum Height Rollers Parallel Table Surface..... 7 in.  
 Centers Between Rollers..... 5 in.

**Construction Info**

Roller..... Synthetic Rubber  
 Housing..... Cast Aluminum  
 Supports..... Cast Iron  
 Column..... Steel  
 Paint Type/Finish..... Enamel

**Other**

Column Diameter..... 2-1/4 in.

**Other Specifications:**

Country of Origin ..... Taiwan  
 Warranty ..... 1 Year  
 Approximate Assembly & Setup Time ..... 45 Minutes  
 Serial Number Location ..... Checked Sticker, On In-feed Portion Of Housing's Roller Cover Side  
 ISO 9001 Factory ..... Yes  
 Certified by a Nationally Recognized Testing Laboratory (NRTL) ..... Yes

**Features:**

- Rollers are Spring Tensioned
- Heavy-Duty Gear Reduction with Hardened Gears
- Universal Positioning with Handle Locks
- Rack and Pinion Horizontal Movement





# MACHINE DATA SHEET

Customer Service #: (570) 546-9663 · To Order Call: (800) 523-4777 · Fax #: (800) 438-5901

## MODEL G7873 1 HP 3-PHASE POWER FEEDER

### Product Dimensions:

Weight..... 135 lbs.  
 Width (side-to-side) x Depth (front-to-back) x Height..... 43-1/2 x 8-1/2 x 13 in.  
 Footprint (Length x Width)..... N/A x N/A

### Shipping Dimensions:

#### Carton #1

Type..... Cardboard Box  
 Content..... Machine  
 Weight..... 62 lbs.  
 Length x Width x Height..... 21 x 12 x 22 in.  
 Must Ship Upright..... No

#### Carton #2

Type..... Cardboard Box  
 Content..... Stand  
 Weight..... 82 lbs.  
 Length x Width x Height..... 30 x 12 x 12 in.  
 Must Ship Upright..... No

### Electrical:

Power Requirement..... 240V, 3-Phase, 60 Hz  
 Full-Load Current Rating..... 3.4A  
 Minimum Circuit Size..... 15A  
 Connection Type..... Cord & Plug  
 Power Cord Included..... Yes  
 Power Cord Length..... 9 ft.  
 Power Cord Gauge..... 16 AWG  
 Plug Included..... No  
 Recommended Plug Type..... 15-15  
 Switch Type..... Forward/Reverse Switch with 2 Speeds  
 Recommended Phase Converter..... G5841

### Motors:

#### Main

Type..... TEFC Induction  
 Horsepower..... 1 HP  
 Phase..... 3-Phase  
 Amps..... 3.4A/2.5A  
 Speed..... 3400 / 1735 RPM  
 Power Transfer..... Gear Drive  
 Bearings..... Sealed & Permanently Lubricated

### Main Specifications:

#### Workpiece Capacities

Minimum Workpiece Length..... 7 in.



**Operation Info**

Number of Feed Speeds..... 4  
Feed Speeds..... 13, 26, 33, 66 FPM  
Swing..... 360 deg.  
Vertical Movement..... 9-7/8 in.  
Horizontal Movement..... 18-1/8 in.  
Rotation..... Forward, Reverse

**Roller Info**

Number of Rollers..... 3  
Roller Width..... 2-1/4 in.  
Roller Diameter..... 4-5/8 in.  
Roller Suspension..... 3/4 in.  
Maximum Height Rollers Parallel Table Surface..... 7 in.  
Centers Between Rollers..... 5 in.

**Construction Info**

Roller..... Synthetic Rubber  
Housing..... Cast Aluminum  
Supports..... Cast Iron  
Column..... Steel  
Paint Type/Finish..... Enamel

**Other**

Column Diameter..... 2-1/4 in.

**Other Specifications:**

Country of Origin ..... Taiwan  
Warranty ..... 1 Year  
Approximate Assembly & Setup Time ..... 45 Minutes  
Serial Number Location ..... Checked Sticker, On In-feed Portion Of Housing's Roller Cover Side  
ISO 9001 Factory ..... Yes  
Certified by a Nationally Recognized Testing Laboratory (NRTL) ..... Yes

**Features:**

- Rollers are Spring Tensioned
- Heavy-Duty Gear Reduction with Hardened Gears
- Universal Positioning with Handle Locks
- Rack and Pinion Horizontal Movement



# Components & Terminology

Refer to **Figure 1** and your power feeder to familiarize yourself with the controls, features, and terminology used in this manual. Doing so will make setup, use, and any future maintenance easier.

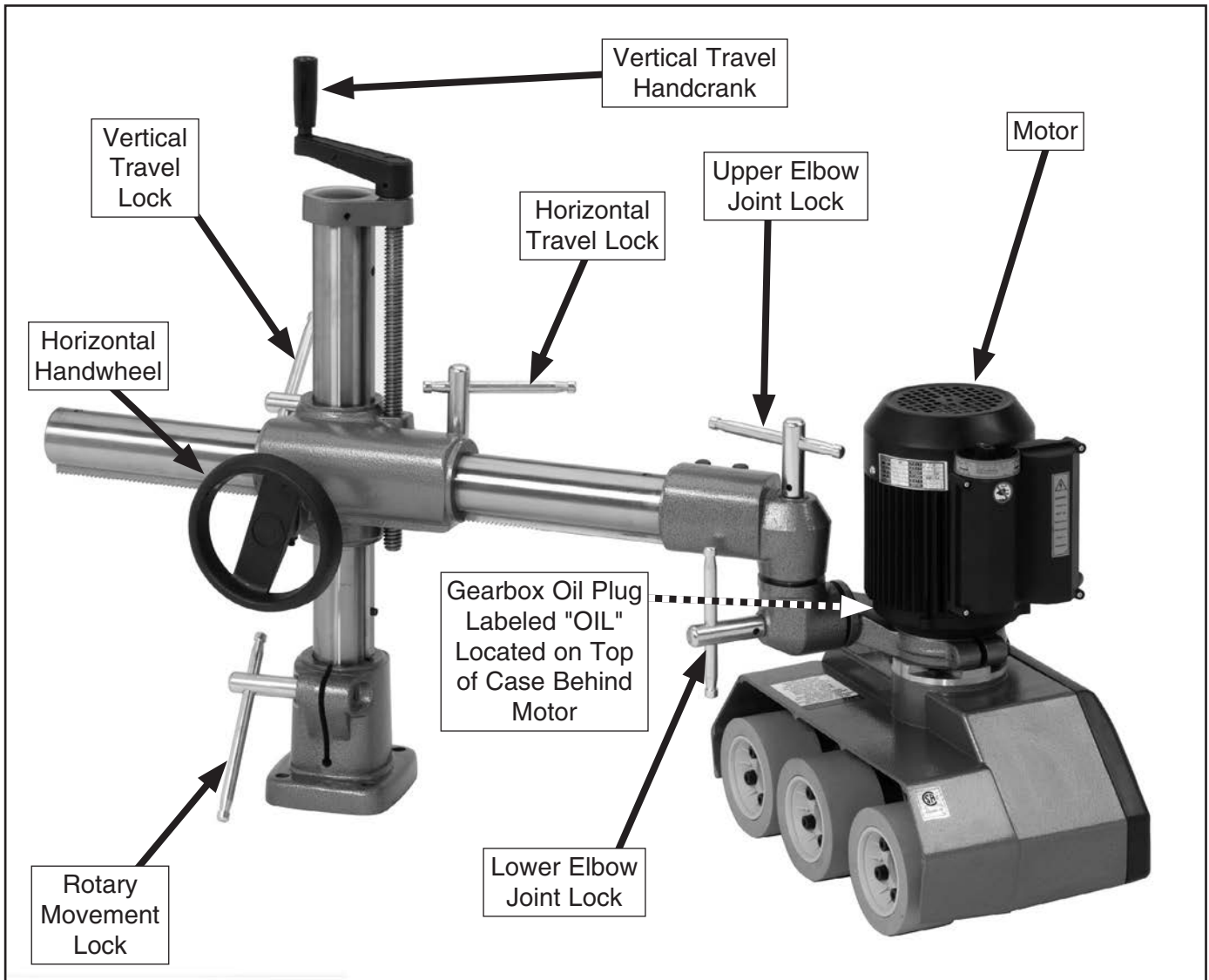

**Figure 1.** Controls and features.



# SECTION 1: SAFETY

## For Your Own Safety, Read Instruction Manual Before Operating This Machine

The purpose of safety symbols is to attract your attention to possible hazardous conditions. This manual uses a series of symbols and signal words intended to convey the level of importance of the safety messages. The progression of symbols is described below. Remember that safety messages by themselves do not eliminate danger and are not a substitute for proper accident prevention measures. Always use common sense and good judgment.

 **DANGER** Indicates an imminently hazardous situation which, if not avoided, **WILL** result in death or serious injury.

 **WARNING** Indicates a potentially hazardous situation which, if not avoided, **COULD** result in death or serious injury.

 **CAUTION** Indicates a potentially hazardous situation which, if not avoided, **MAY** result in minor or moderate injury. It may also be used to alert against unsafe practices.

**NOTICE** This symbol is used to alert the user to useful information about proper operation of the machine.

## Safety Instructions for Machinery

### **WARNING**

**OWNER'S MANUAL.** Read and understand this owner's manual **BEFORE** using machine.

**TRAINED OPERATORS ONLY.** Untrained operators have a higher risk of being hurt or killed. Only allow trained/supervised people to use this machine. When machine is not being used, disconnect power, remove switch keys, or lock-out machine to prevent unauthorized use—especially around children. Make your workshop kid proof!

**DANGEROUS ENVIRONMENTS.** Do not use machinery in areas that are wet, cluttered, or have poor lighting. Operating machinery in these areas greatly increases the risk of accidents and injury.

**MENTAL ALERTNESS REQUIRED.** Full mental alertness is required for safe operation of machinery. Never operate under the influence of drugs or alcohol, when tired, or when distracted.

**ELECTRICAL EQUIPMENT INJURY RISKS.** You can be shocked, burned, or killed by touching live electrical components or improperly grounded machinery. To reduce this risk, only allow qualified service personnel to do electrical installation or repair work, and always disconnect power before accessing or exposing electrical equipment.

**DISCONNECT POWER FIRST.** Always disconnect machine from power supply **BEFORE** making adjustments, changing tooling, or servicing machine. This prevents an injury risk from unintended startup or contact with live electrical components.

**EYE PROTECTION.** Always wear ANSI-approved safety glasses or a face shield when operating or observing machinery to reduce the risk of eye injury or blindness from flying particles. Everyday eyeglasses are **NOT** approved safety glasses.



# WARNING

**WEARING PROPER APPAREL.** Do not wear clothing, apparel or jewelry that can become entangled in moving parts. Always tie back or cover long hair. Wear non-slip footwear to reduce risk of slipping and losing control or accidentally contacting cutting tool or moving parts.

**HAZARDOUS DUST.** Dust created by machinery operations may cause cancer, birth defects, or long-term respiratory damage. Be aware of dust hazards associated with each workpiece material. Always wear a NIOSH-approved respirator to reduce your risk.

**HEARING PROTECTION.** Always wear hearing protection when operating or observing loud machinery. Extended exposure to this noise without hearing protection can cause permanent hearing loss.

**REMOVE ADJUSTING TOOLS.** Tools left on machinery can become dangerous projectiles upon startup. Never leave chuck keys, wrenches, or any other tools on machine. Always verify removal before starting!

**USE CORRECT TOOL FOR THE JOB.** Only use this tool for its intended purpose—do not force it or an attachment to do a job for which it was not designed. Never make unapproved modifications—modifying tool or using it differently than intended may result in malfunction or mechanical failure that can lead to personal injury or death!

**AWKWARD POSITIONS.** Keep proper footing and balance at all times when operating machine. Do not overreach! Avoid awkward hand positions that make workpiece control difficult or increase the risk of accidental injury.

**CHILDREN & BYSTANDERS.** Keep children and bystanders at a safe distance from the work area. Stop using machine if they become a distraction.

**GUARDS & COVERS.** Guards and covers reduce accidental contact with moving parts or flying debris. Make sure they are properly installed, undamaged, and working correctly **BEFORE** operating machine.

**FORCING MACHINERY.** Do not force machine. It will do the job safer and better at the rate for which it was designed.

**NEVER STAND ON MACHINE.** Serious injury may occur if machine is tipped or if the cutting tool is unintentionally contacted.

**STABLE MACHINE.** Unexpected movement during operation greatly increases risk of injury or loss of control. Before starting, verify machine is stable and mobile base (if used) is locked.

**USE RECOMMENDED ACCESSORIES.** Consult this owner's manual or the manufacturer for recommended accessories. Using improper accessories will increase the risk of serious injury.

**UNATTENDED OPERATION.** To reduce the risk of accidental injury, turn machine **OFF** and ensure all moving parts completely stop before walking away. Never leave machine running while unattended.

**MAINTAIN WITH CARE.** Follow all maintenance instructions and lubrication schedules to keep machine in good working condition. A machine that is improperly maintained could malfunction, leading to serious personal injury or death.

**DAMAGED PARTS.** Regularly inspect machine for damaged, loose, or mis-adjusted parts—or any condition that could affect safe operation. Immediately repair/replace **BEFORE** operating machine. For your own safety, **DO NOT** operate machine with damaged parts!

**MAINTAIN POWER CORDS.** When disconnecting cord-connected machines from power, grab and pull the plug—**NOT** the cord. Pulling the cord may damage the wires inside. Do not handle cord/plug with wet hands. Avoid cord damage by keeping it away from heated surfaces, high traffic areas, harsh chemicals, and wet/damp locations.

**EXPERIENCING DIFFICULTIES.** If at any time you experience difficulties performing the intended operation, stop using the machine! Contact our Technical Support at (570) 546-9663.



# Additional Safety for Power Feeders

## **WARNING**

Serious injury or death can occur from getting hands, clothing, or jewelry entangled in moving parts of power feeder or being pulled into cutting tool on attached machinery. Workpieces ejected by attached machine can strike operator or bystanders with significant force, causing impact injuries. To minimize risk of injury, anyone operating this machine **MUST** completely heed hazards and warnings below.

**ATTACHED MACHINERY.** Follow all warnings and safety information for attached machine doing cutting work.

**HAND SAFETY.** To reduce risk of accidental entanglement/pinch injuries between power feeder rollers and workpiece, or contact with blade/cutter of associated machine, keep hands away from rotating parts of power feeder. Turn power feeder and associated machine **OFF** before removing chips, sawdust, or cutoffs—**DO NOT** use your hands.

**INSTALLING GUARDS.** To reduce risk of kickback and accidental contact with blade/cutter of associated machine, always install guards, fences, and hold-downs before starting attached machine and power feeder. Repair or replace guards promptly if they become damaged.

**KICKBACK.** Occurs when workpiece is ejected from machine at a high rate of speed. To reduce risk of kickback-related injuries (blindness, broken bones, bruises, amputation, severe lacerations, and death), use quality workpieces and proper setup or maintenance of power feeder or associated machine. Never stand in path of workpiece.

**FEATHERBOARD.** When cutting long or large stock that is difficult to feed properly, use a featherboard with power feeder (on the infeed side) to maintain even pressure and control of workpiece against fence, and to help reduce risk of kickback.

**FEED WORKPIECE PROPERLY.** To reduce risk of kickback, verify blade or cutter of associated machine is at full speed before feeding stock with power feeder. Avoid feeding workpiece too quickly. Always verify power feeder wheels are slightly lower than workpiece to ensure it will not slip during cutting operation. Stop power feeder **BEFORE** stopping cutting tool.

**WORKPIECE SUPPORT.** Loss of workpiece control while feeding can increase risk of kickback. Support workpiece continuously during operation as required. Use auxiliary stands or support tables for long or wide stock.

**ADJUSTMENTS/MAINTENANCE.** Make sure power feeder and associated machine are turned **OFF**, disconnected from power, and all moving parts are completely stopped before doing adjustments or maintenance.

## **WARNING**

Like all machines there is danger associated with this machine. Accidents are frequently caused by lack of familiarity or failure to pay attention. Use this machine with respect and caution to lessen the possibility of operator injury. If normal safety precautions are overlooked or ignored, serious personal injury may occur.

## **CAUTION**

No list of safety guidelines can be complete. Every shop environment is different. Always consider safety first, as it applies to your individual working conditions. Use this and other machinery with caution and respect. Failure to do so could result in serious personal injury, damage to equipment, or poor work results.



# SECTION 2: POWER SUPPLY

## Availability

Before installing the machine, consider the availability and proximity of the required power supply circuit. If an existing circuit does not meet the requirements for this machine, a new circuit must be installed. To minimize the risk of electrocution, fire, or equipment damage, installation work and electrical wiring must be done by an electrician or qualified service personnel in accordance with all applicable codes and standards.

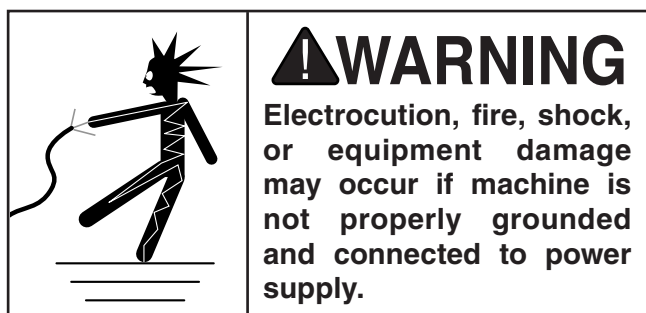

## Full-Load Current Rating

The full-load current rating is the amperage a machine draws at 100% of the rated output power. On machines with multiple motors, this is the amperage drawn by the largest motor or sum of all motors and electrical devices that might operate at one time during normal operations.

**G4181 220V, 1-Ph..... 4.2/2.5A**

**G7873 220V, 3-Ph ..... 3.4/2.5A**

The full-load current is not the maximum amount of amps that the machine will draw. If the machine is overloaded, it will draw additional amps beyond the full-load rating.

If the machine is overloaded for a sufficient length of time, damage, overheating, or fire may result—especially if connected to an undersized circuit. To reduce the risk of these hazards, avoid overloading the machine during operation and make sure it is connected to a power supply circuit that meets the specified circuit requirements.

## G4181 Circuit Requirements

This machine is prewired to operate on a power supply circuit that has a verified ground and meets the following requirements:

**Nominal Voltage .....220V**  
**Cycle.....60 Hz**  
**Phase..... 1-Phase**  
**Circuit Rating..... 15 Amps**  
**Plug/Receptacle ..... NEMA 6-15**

## G7873 Circuit Requirements

This machine is prewired to operate on a power supply circuit that has a verified ground and meets the following requirements:

**Nominal Voltage .....220V**  
**Cycle.....60 Hz**  
**Phase..... 3-Phase**  
**Circuit Rating..... 15 Amps**  
**Plug/Receptacle .....NEMA 15-15**

A power supply circuit includes all electrical equipment between the breaker box or fuse panel in the building and the machine. The power supply circuit used for this machine must be sized to safely handle the full-load current drawn from the machine for an extended period of time. (If this machine is connected to a circuit protected by fuses, use a time delay fuse marked D.)

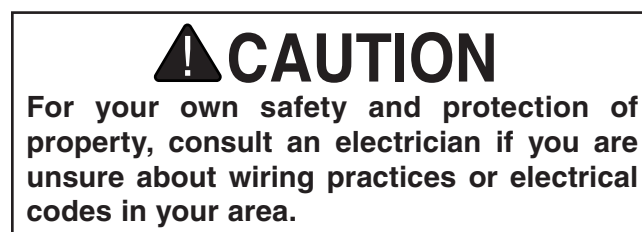

**Note:** *Circuit requirements in this manual apply to a dedicated circuit—where only one machine will be running on the circuit at a time. If machine will be connected to a shared circuit where multiple machines may be running at the same time, consult an electrician or qualified service personnel to ensure circuit is properly sized for safe operation.*



## Grounding Instructions

This machine **MUST** be grounded. In the event of certain malfunctions or breakdowns, grounding reduces the risk of electric shock by providing a path of least resistance for electric current.

The plug specified under "Circuit Requirements" on the previous page has a grounding prong that must be attached to the equipment-grounding wire on the included power cord. The plug must only be inserted into a matching receptacle (see the following figures) that is properly installed and grounded in accordance with all local codes and ordinances.

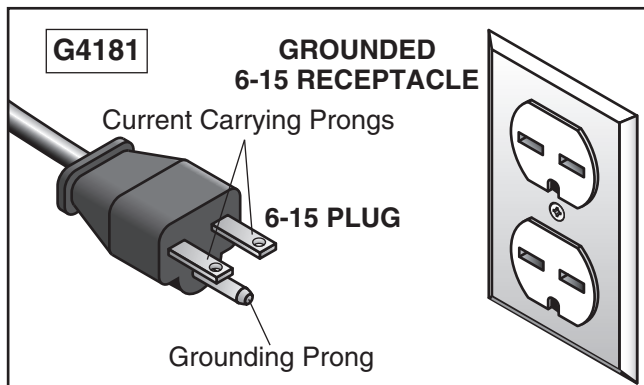

Figure 2. Typical 6-15 plug and receptacle.

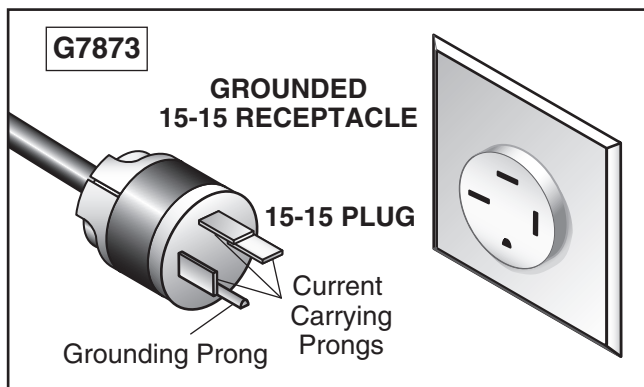

Figure 3. Typical 15-15 plug and receptacle.

## NOTICE

No adapter is available or should be used with this machine. If the machine must be reconnected for use on a different type of electric circuit, the reconnection should be made by qualified service personnel; and after reconnection, the machine must comply with all local codes and ordinances.

## WARNING

Serious injury could occur if you connect machine to power before completing setup process. **DO NOT** connect to power until instructed later in this manual.

Improper connection of the equipment-grounding wire can result in a risk of electric shock. The wire with green insulation (with or without yellow stripes) is the equipment-grounding wire. If repair or replacement of the power cord or plug is necessary, do not connect the equipment-grounding wire to a live (current carrying) terminal.

Check with a qualified electrician or service personnel if you do not understand these grounding requirements, or if you are in doubt about whether the tool is properly grounded. If you ever notice that a cord or plug is damaged or worn, disconnect it from power, and immediately replace it with a new one.

## Extension Cords

We do not recommend using an extension cord with this machine. If you must use an extension cord, only use it if absolutely necessary and only on a temporary basis.

Extension cords cause voltage drop, which can damage electrical components and shorten motor life. Voltage drop increases as the extension cord size gets longer and the gauge size gets smaller (higher gauge numbers indicate smaller sizes).

Any extension cord used with this machine must be in good condition and contain a ground wire and matching plug/receptacle. Additionally, it must meet the following size requirements:

Minimum AWG (G4181) ..... 16 AWG, 3W, 300V  
Minimum AWG (G7873)..... 16 AWG, 4W, 300V  
Maximum Length (Shorter is Better).....50 ft.



# SECTION 3: SETUP

## Unpacking

This machine was carefully packaged for safe transport. When unpacking, separate all enclosed items from packaging materials and inspect them for shipping damage. ***If items are damaged, please call us immediately at (570) 546-9663.***

**IMPORTANT:** Save all packaging materials until you are completely satisfied with the machine and have resolved any issues between Grizzly or the shipping agent. *You MUST have the original packaging to file a freight claim. It is also extremely helpful if you need to return your machine later.*

	<p><b>! WARNING</b> <b>SUFFOCATION HAZARD!</b> Keep children and pets away from plastic bags or packing materials shipped with this machine. Discard immediately.</p>
--	---

## Needed for Setup

The following are needed to complete the setup process, but are not included with your machine.

Description	Qty
• Safety Glasses .....	1
• Cleaner/Degreaser .....	As Needed
• Light Machine Oil .....	As Required
• Disposable Shop Rags.....	As Needed
• Medium Grade Thread Locking Liquid.....	1



# Inventory

The following is a list of items shipped with your machine. Before beginning setup, lay these items out and inventory them.

If any non-proprietary parts are missing (e.g. a nut or a washer), we will gladly replace them; or for the sake of expediency, replacements can be obtained at your local hardware store.

<b>Box Inventory (Figures 4 &amp; 5)</b>	<b>Qty</b>
<b>A.</b> Power Feeder Assembly .....	1
<b>B.</b> Lubricator.....	1
<b>C.</b> Base and Column Assembly .....	1
<b>D.</b> Elbow Joint Assembly .....	1
<b>E.</b> Base Bolt Pattern Template.....	1
<b>F.</b> Handcrank Handle .....	1
<b>G.</b> Horizontal Column Assembly .....	1

## ***NOTICE***

**If you cannot find an item on this list, carefully check around/inside the machine and packaging materials. Often, these items get lost in packaging materials while unpacking or they are pre-installed at the factory.**

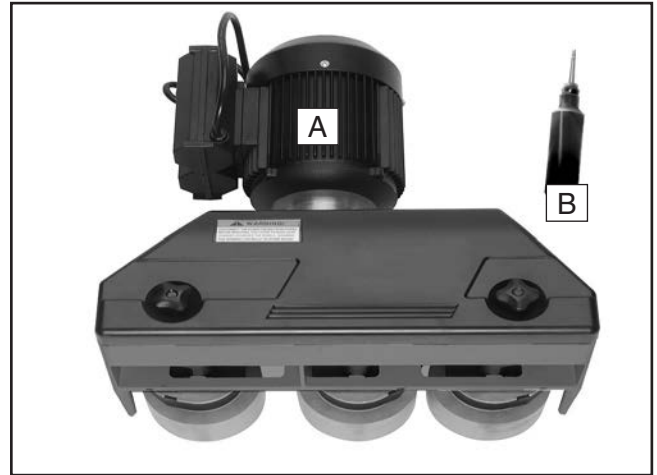

**Figure 4.** Power feeder inventory.

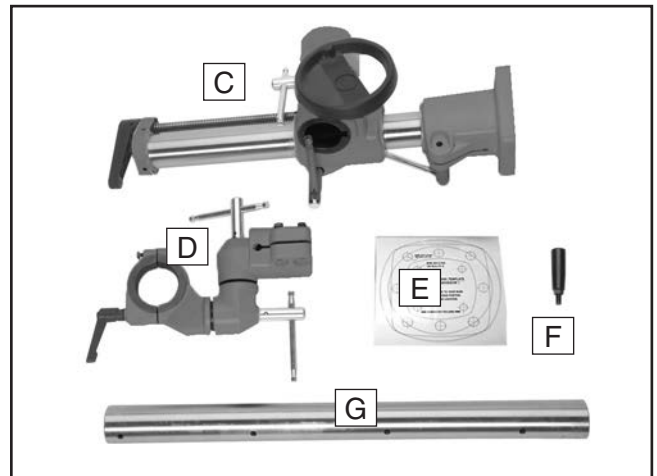

**Figure 5.** Base inventory.



# Cleanup

The unpainted surfaces of your machine are coated with a heavy-duty rust preventative that prevents corrosion during shipment and storage. This rust preventative works extremely well, but it will take a little time to clean.

Be patient and do a thorough job cleaning your machine. The time you spend doing this now will give you a better appreciation for the proper care of your machine's unpainted surfaces.

There are many ways to remove this rust preventative, but the following steps work well in a wide variety of situations. Always follow the manufacturer's instructions with any cleaning product you use and make sure you work in a well-ventilated area to minimize exposure to toxic fumes.

## Before cleaning, gather the following:

- Disposable rags
- Cleaner/degreaser (WD•40 works well)
- Safety glasses & disposable gloves
- Plastic paint scraper (optional)

## Basic steps for removing rust preventative:

1. Put on safety glasses.
2. Coat the rust preventative with a liberal amount of cleaner/degreaser, then let it soak for 5–10 minutes.
3. Wipe off the surfaces. If your cleaner/degreaser is effective, the rust preventative will wipe off easily. If you have a plastic paint scraper, scrape off as much as you can first, then wipe off the rest with the rag.
4. Repeat **Steps 2–3** as necessary until clean, then coat all unpainted surfaces with a quality metal protectant to prevent rust.

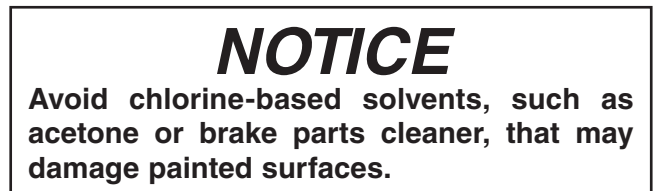
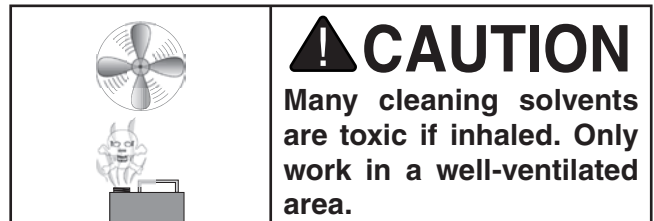
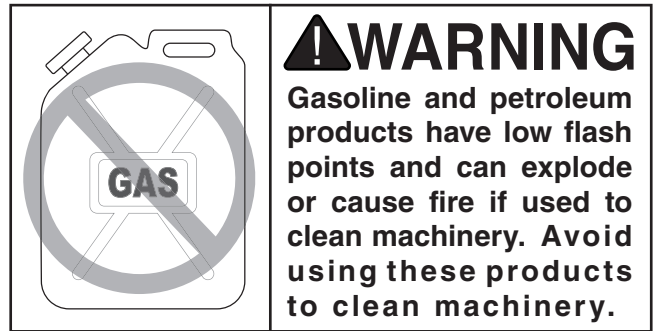

## T23692—Orange Power Degreaser

A great product for removing the waxy shipping grease from your machine during clean up.

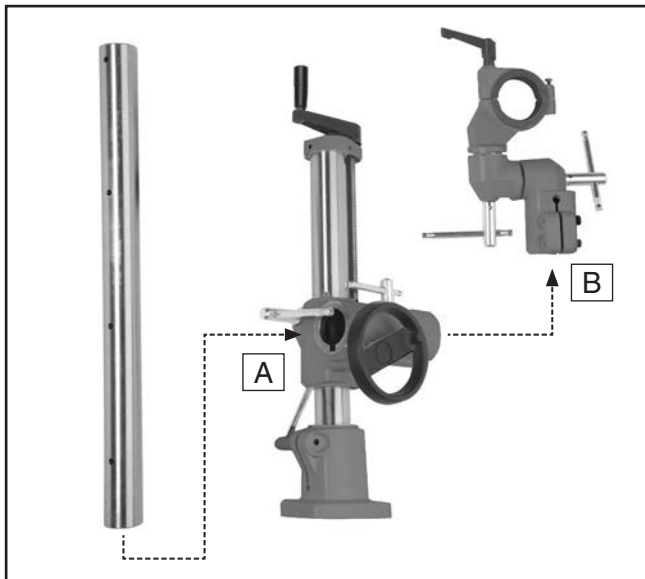

Figure 6. T23692 Orange Power Degreaser.



# Assembly

To correctly position this power feeder on your table top, completely assemble the power feeder first in the order of **A**, **B** and **C** as shown in **Figures 7** and **8**. Next, refer to **Base Mounting** on **Page 15**. With the power feeder unit completely assembled, it will be easier to locate where on the table top you will need to drill your base mounting holes, so you can take advantage of the full range of power feeder swing and adjustments.



**Figure 7.** Stand assembly.

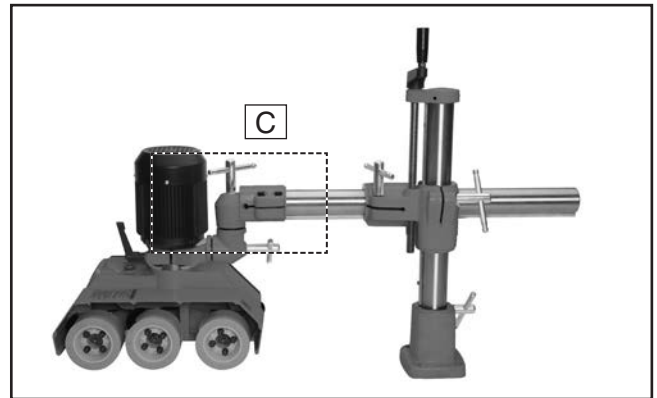

**Figure 8.** Assembled unit.

## **!**WARNING

You **MUST** assemble all guards, fences, and holdowns before starting your machine or power feeder. Failure to heed this warning could result in serious personal injury.



# Base Mounting

Position the power feeder on the table top to determine where to drill your base mounting holes, so you can maximize power feeder swing and adjustment options.

There are two mounting options available: **Through Bolt Mounting** and **Direct Mounting** (discussed on **Page 18**). Choose an option that suits your requirements.

Whichever way you mount your power feeder, you must be able to use the handcranks and lock levers to position the rubber wheels parallel with the table surface and approximately  $\frac{1}{8}$ " lower than the thickness of your workpiece.

Also, you must be able to point the power feeder slightly towards the machine fence (see **Figure 9**). In other words, the tracking of the power feeder must be toed-in approximately  $1^\circ$  to  $1.5^\circ$  degrees toward the machine fence, so the rubber wheels slightly push the workpiece against the fence during cutting operations.

If cutting long or large stock that is difficult to feed properly, use a featherboard *before* the power feeder (on the infeed side) to maintain even pressure and control of the workpiece against the fence.

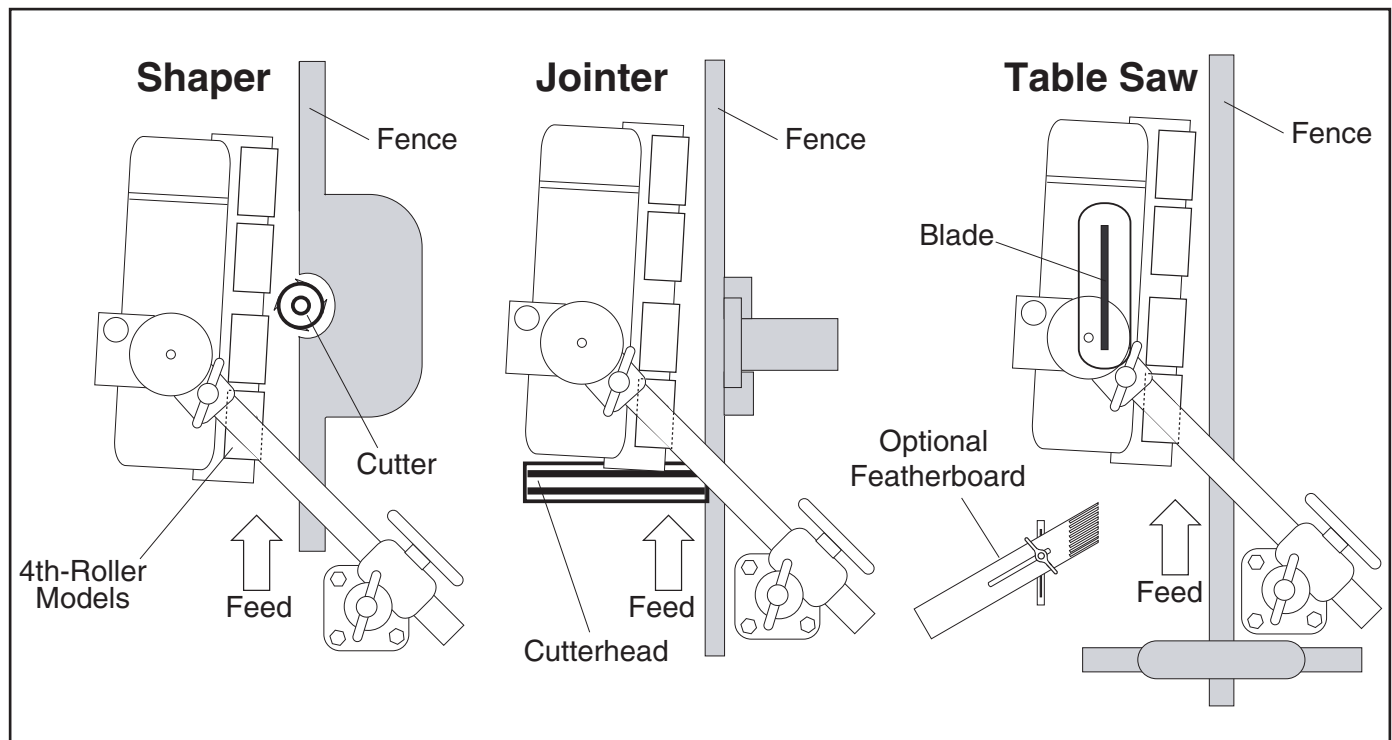

**Figure 9.** Typical power feeder mounting on a shaper, jointer, and table saw.



# Mounting Options

To correctly position this power feeder on your table top, completely assemble the power feeder first, then refer to this section and mount your base to the table using one of the two methods below. The reason for this order is that with the power feeder unit completely assembled, it will be easier to locate where on the table top you will need to drill your base mounting holes, so you can take advantage of the full range of power feeder swing and adjustments.

## Through-Bolt Mounting

We recommend that you mount your new power feeder to the machine table with through bolts, nuts, and washers (see **Figure 10**). This option will give the most rigidity and clamping strength to prevent the feeder base from twisting out of alignment during use. However, if under-table support webs interfere with washer or nut locations under the table, you must use an optional clamping kit, or drill and thread holes directly into the table as described in **Direct Mounting**.

## Direct Mounting

Use the included mounting template to drill and tap your table, so the power feeder base can be directly mounted to the table surface (see **Figure 11**). If the table is thinner than  $\frac{3}{8}$ " thick where the threaded holes would be drilled and tapped, or if support webbing is in the way, the threads may strip or loosen as the power feeder is used. Thread locking compound will not cure this situation. Revert to the **Through-Bolt Mounting** option. In any case, make sure to use a medium-grade liquid thread locking compound on all threads.

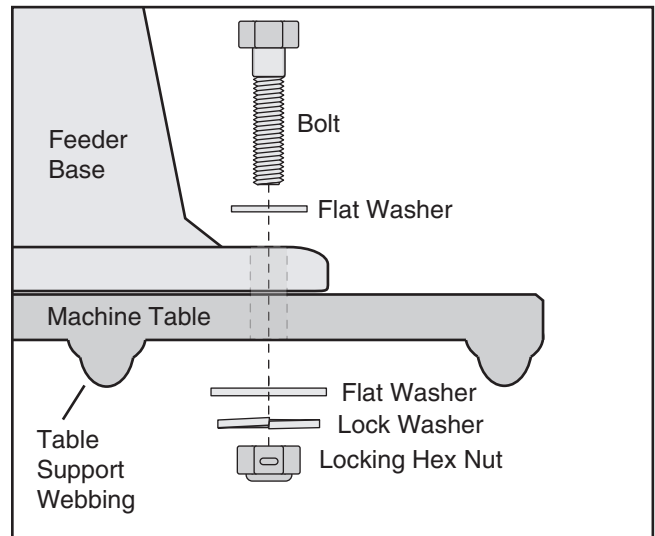

**Figure 10.** Through-bolt mounting.

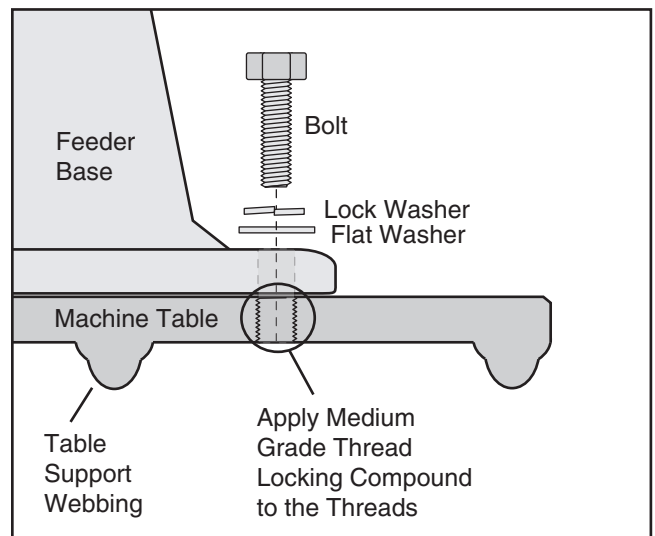

**Figure 11.** Direct mounting.



# Test Run

Once the power feeder assembly is complete and mounted on the table, you must test run your power feeder to make sure it runs properly.

If, during the test run, you cannot easily locate the source of an unusual noise or vibration, stop using the power feeder immediately, then review the **Troubleshooting** table on **Page 24**.

If you still cannot remedy a problem, contact our Technical Support at (570) 546-9663 for assistance.

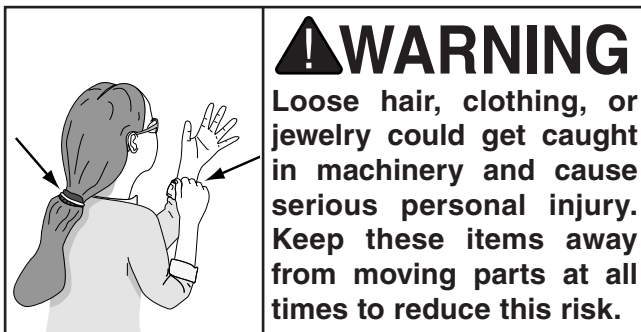

## To test run the power feed:

1. Read the entire instruction manual first!
2. Make sure all tools and foreign objects have been removed from the tabletop area.
3. Make sure that the power feeder gearbox oil level is full, the oil level should be 1" below the oil fill port. Refer to **Figure 16** on **Page 22** for oil fill port location.
4. Ensure that all tools and objects used during set up are cleared away from the machine.
5. Adjust and lock the power feeder so the wheels are held approximately one inch above the table and nothing will interfere with wheel rotation.

6. Connect the power feeder to the power supply and use the feed direction switch (see **Figure 12**) to test operation in both directions and both speeds.

—Listen and watch for abnormal noises or vibrations. The power feeder should run smoothly.

—Correct for any unusual noises or vibrations before operating the power feeder any further. Always disconnect the power feeder from power when investigating or correcting potential problems.



**Figure 12.** Feed direction and speed switch.



# SECTION 4: OPERATIONS

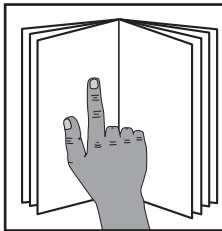

## **!WARNING**

To reduce your risk of serious injury, read this entire manual **BEFORE** using machine.

## **!WARNING**

To reduce risk of eye injury from flying chips or lung damage from breathing dust, always wear safety glasses and a respirator when operating this machine.

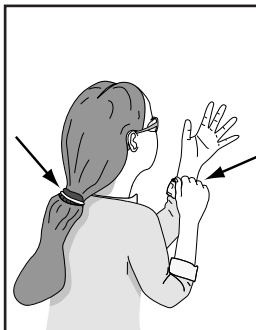
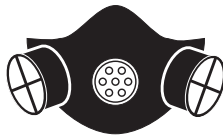

## **!WARNING**

Loose hair, clothing, or jewelry could get caught in machinery and cause serious personal injury. Keep these items away from moving parts at all times to reduce this risk.

## **NOTICE**

If you are not experienced with this type of machine, **WE STRONGLY RECOMMEND** that you seek additional training outside of this manual. Read books/magazines or get formal training before beginning any projects. Regardless of the content in this section, Grizzly Industrial will not be held liable for accidents caused by lack of training.

## Basic Use and Care

### **!WARNING**

You **MUST** assemble all guards, fences, and hold-downs before starting your machine or power feeder. Failure to heed this warning could result in amputation or death!

Power feeders reduce kickback hazards and improve cutting results by feeding in a consistent and stable manner. Remember, do not stand in the path of potential kickback. When not in use, support the power feeder with a wooden block so the rubber wheels are raised above the table and do not compress from the weight of the power feeder.

The universal joints on this power feeder allow you to adjust the power feeder tracking and height to accommodate many workpiece sizes. Before loosening any lock lever, always support the power feeder with a block of wood, so the power feeder does not drop and cause damage.

Adjust the power feeder so it is toed-in approximately 1° to 1.5° degrees towards the machine fence. This adjustment will ensure that the power feeder wheels slightly push the workpiece against the fence during cutting operations (see **Figure 9** on **Page 17**). A featherboard may be used on the infeed side to assist with feeding long or large stock.

Next, adjust the power feeder so the rubber wheels are parallel with the table surface, and are 1/8" lower than the thickness of your workpiece. This adjustment ensures that the workpiece will not slip or hang in the middle of a cut. Always double check that the power feeder wheels are slightly lower than the workpiece before you begin feeding operations. Otherwise, the workpiece may slip and kickback.



# Changing Feed Speed

Your power feeder has the option to feed a workpiece at 13, 26, 33, and 66 feet per minute. These rates are achieved by changing the combination of change gears (see **Figure 13**), and turning the motor switch to the high or low range operation (see **Figure 14**).

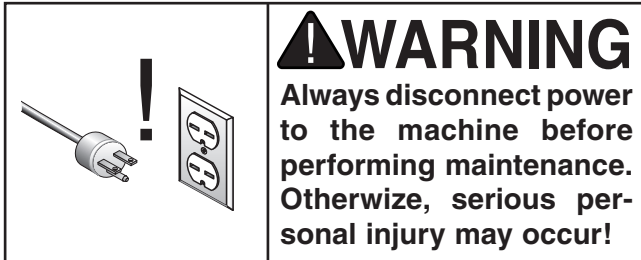

## To change the feed rate of your power feeder:

1. Turn the dial to OFF (the "0" position).
2. DISCONNECT MACHINE FROM POWER!
3. Refer to the change gear chart (see **Figure 14**) below to find the gear combination required for your chosen feed rate.

4. Remove the chain cover and the two hex nuts securing the position **A** & **B** change gears to the shafts.
5. Swap the required change gears so the gear hubs are facing toward the power feeder (shown in positions **A** & **B** in **Figure 13**).

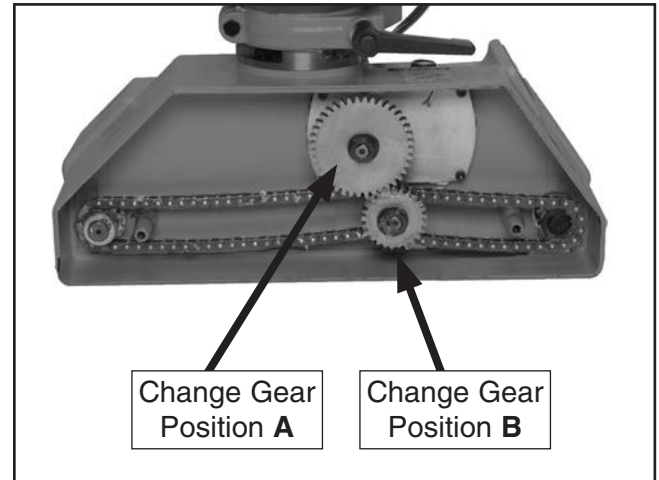

**Figure 13.** Change gear locations.

6. Re-install the hex nuts and the chain cover.

	Low Speed: <b>A</b> , 25 Tooth + <b>B</b> , 40 Tooth = <b>13 Ft Per Min.</b>
	Low Speed: <b>A</b> , 40 Tooth + <b>B</b> , 25 Tooth = <b>26 Ft Per Min.</b>
	High Speed: <b>A</b> , 25 Tooth + <b>B</b> , 40 Tooth = <b>33 Ft Per Min.</b>
	High Speed: <b>A</b> , 40 Tooth + <b>B</b> , 25 Tooth = <b>66 Ft Per Min.</b>
	Motor OFF.

	Low Speed W/Optional G4184 Gear Kit: <b>A</b> , 21 Tooth + <b>B</b> , 44 Tooth = <b>9.4 Ft Per Min.</b>
	Low Speed W/Optional G4184 Gear Kit: <b>A</b> , 44 Tooth + <b>B</b> , 21 Tooth = <b>18.8 Ft Per Min.</b>
	High Speed W/Optional G4184 Gear Kit: <b>A</b> , 21 Tooth + <b>B</b> , 44 Tooth = <b>41.4 Ft Per Min.</b>
	High Speed W/Optional G4184 Gear Kit: <b>A</b> , 44 Tooth + <b>B</b> , 21 Tooth = <b>82.7 Ft Per Min.</b>

**Figure 14.** Change gear chart.



# SECTION 5: MAINTENANCE



## Schedule

For optimum performance from your machine, follow this maintenance schedule and refer to any specific instructions given in this section.

### Daily Check:

- Loose mounting bolts.
- Worn switch.
- Worn or damaged cords and plugs.
- Damaged or worn wheel rubber.
- Any other condition that could hamper the safe operation of this machine.

## Cleaning

Frequently blow-off sawdust with compressed air. This is especially important for the internal working parts and motor. Dust build-up around the motor is a sure way to decrease its life span. If the wheels become loaded up with pitch, oil, or other residues, wipe them clean using a clean rag and a mild solvent. Avoid touching the plastic or paint with mineral spirits or you may damage the surfaces.

## Lubrication

- To prevent surface rust and binding, periodically clean and oil all lock lever and lead screw threads with a light machine oil.

- After the first 200 hours of use, or after the first month, change the gearbox oil with 5.1 fluid ounces of a good automotive grade 80-90W gear oil. For the remaining life of the power feeder, change the oil every 1000 hours, or every 6 months. **Note:** To drain the unit, remove the fill plug labeled "OIL" and invert the power feeder.
- Every 40 hours of use, or once every two weeks, wipe clean and lubricate the wheel grease fittings (see **Figure 15**) with one pump from a grease gun filled with automotive grade GL-2 grease.

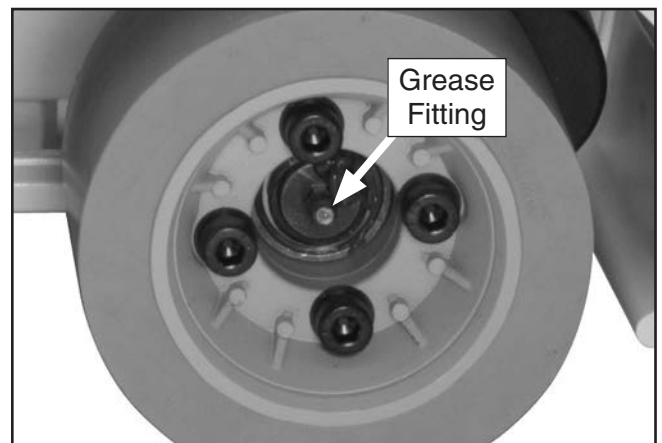

**Figure 15.** Wheel lubrication.

- As required to prevent rust, binding, and dry spots, brush the sprockets, chain, and change gears (see **Figure 16**) with a light film of an automotive grade GL-2 grease.

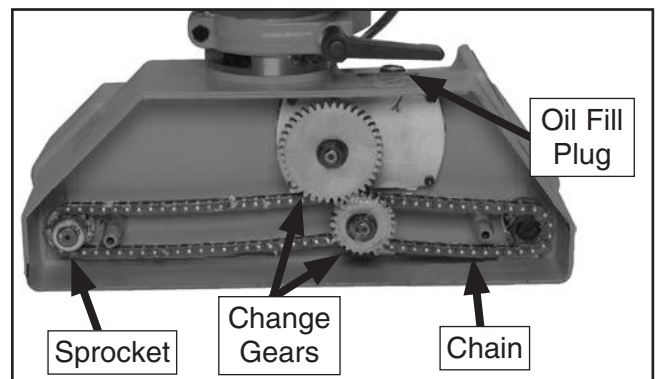

**Figure 16.** Sprockets, chain, and gears.



# SECTION 6: ACCESSORIES

## **⚠️ WARNING**

Installing unapproved accessories may cause machine to malfunction, resulting in serious personal injury or machine damage. To reduce this risk, only install accessories recommended for this machine by Grizzly.

## **NOTICE**

Refer to our website or latest catalog for additional recommended accessories.

### **D3122—SHOP FOX® Push Stick**

Measuring 13½" overall, this push stick allows the operator to keep their hands at a safe distance away from the blade or cutter.



Figure 17. D3122 SHOP FOX® Push Stick.

### **D3096—SHOP FOX® Featherboard**

Designed to lock into a standard 3/8" x 3/4" miter slot, this featherboard is fully adjustable to accommodate a wide range of workpieces. Reduce the likelihood of kickback with this convenient accessory.



Figure 18. D3096 SHOP FOX® Featherboard.

### **G3101—Polyurethane Roller**

### **G2516—Rubber Roller**

Polyurethane or rubber rollers fits the G3100 or G1759 roller flange tire system.

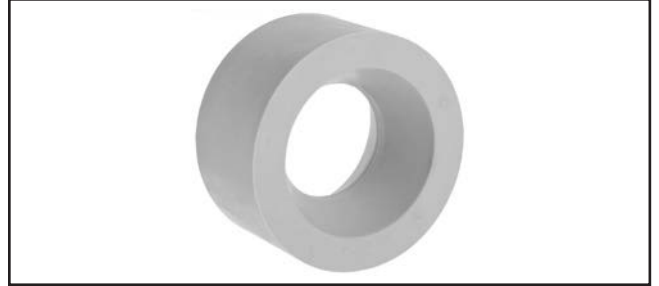

Figure 19. G3101 Polyurethane Roller.

### **G3100—Flange with Polyurethane Roller**

### **G1759—Flange with Rubber Roller**

The Model G4181 or G7873 Power Feeder can save you money over the long haul by replacing the rollers with one of these roller flange and tire systems. Once you buy the complete flange and tire system, you simply replace the inexpensive rubber or polyurethane tires when they wear out.



Figure 20. G3100 Flange with Polyurethane Roller.

**order online at [www.grizzly.com](http://www.grizzly.com) or call 1-800-523-4777**



# SECTION 7: SERVICE

Review the troubleshooting and procedures in this section if a problem develops with your machine. If you need replacement parts or additional help with a procedure, call our Technical Support. **Note:** *Please gather the serial number and manufacture date of your machine before calling.*

## Troubleshooting

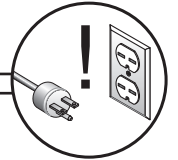

### Motor & Electrical

Symptom	Possible Cause	Possible Solution
Motor will not start.	<ol style="list-style-type: none"> <li>1. Low voltage.</li> <li>2. Open circuit in motor or loose connections.</li> <li>3. Blown fuse tripped circuit breaker.</li> <li>4. Start capacitor is at fault.</li> <li>5. Motor switch or motor is at fault.</li> </ol>	<ol style="list-style-type: none"> <li>1. Check power supply for proper voltage.</li> <li>2. Inspect all lead connections on motor and circuit board for loose or open connections.</li> <li>3. Repair for cause of overload and replace fuse or reset circuit breaker.</li> <li>4. Replace start capacitor.</li> <li>5. Replace switch, or motor.</li> </ol>
Fuses or circuit breakers trip.	<ol style="list-style-type: none"> <li>1. Short circuit in line cord or plug.</li> <li>2. Short circuit in motor or loose connections.</li> <li>3. Power feeder rollers are jammed.</li> </ol>	<ol style="list-style-type: none"> <li>1. Inspect cord or plug for damaged insulation and shorted wires and replace extension cord.</li> <li>2. Inspect all connections on motor for loose or shorted terminals or worn insulation.</li> <li>3. Disconnect all machinery from power and correct for cause of jamming.</li> </ol>
Motor overheats.	<ol style="list-style-type: none"> <li>1. Motor overloaded.</li> <li>2. Air circulation through the motor restricted.</li> </ol>	<ol style="list-style-type: none"> <li>1. Reduce power feeder feed rate.</li> <li>2. Clean out motor fan cover to provide normal air circulation.</li> </ol>
Machine operates in reverse (G7873 only)	<ol style="list-style-type: none"> <li>1. Power connections wired out of phase (G7873 only).</li> </ol>	<ol style="list-style-type: none"> <li>1. Swap any two of the three incoming hot wires on the motor direction switch shown (see terminals 1, 5, and 21 shown on <b>Page 27</b>).</li> </ol>
Workpiece jams when feeding under rollers.	<ol style="list-style-type: none"> <li>1. Rollers set too low.</li> <li>2. Feeder at wrong angle.</li> </ol>	<ol style="list-style-type: none"> <li>1. Raise feeder.</li> <li>2. Adjust angle.</li> </ol>
Workpiece slips while passing beneath rollers.	<ol style="list-style-type: none"> <li>1. Rollers positioned too high, no traction.</li> <li>2. Feeding too fast.</li> <li>3. Rollers are dirty or oily.</li> <li>4. Worn roller(s).</li> </ol>	<ol style="list-style-type: none"> <li>1. Lower feeder.</li> <li>2. Slow feed speed.</li> <li>3. Clean roller surface with a mild solvent.</li> <li>4. Replace roller(s) (<b>Page 25</b>).</li> </ol>
Workpiece cut is burnt.	<ol style="list-style-type: none"> <li>1. Wrong feed speed.</li> <li>2. Cutter is at fault.</li> </ol>	<ol style="list-style-type: none"> <li>1. Adjust feed speed.</li> <li>2. Sharpen or replace dull blade or cutter.</li> </ol>
Rough finish or chipped grain on workpiece.	<ol style="list-style-type: none"> <li>1. Feed speed too fast.</li> <li>2. Dull cutter or blade.</li> <li>3. Power feeder angle is not toed in to keep workpiece against the fence.</li> </ol>	<ol style="list-style-type: none"> <li>1. Slow speed.</li> <li>2. Replace with sharp cutter or blade.</li> <li>3. Adjust power feeder so it is toed-in 1° to 1.5° toward the fence.</li> </ol>
Fuzzy grain occurs when planing or moulding.	<ol style="list-style-type: none"> <li>1. Lumber has high moisture content.</li> <li>2. Dull knives/cutter.</li> </ol>	<ol style="list-style-type: none"> <li>1. If moisture content is higher than 20%, sticker and allow to dry.</li> <li>2. Sharpen or replace knives.</li> </ol>
Workpiece hangs and does not enter the machine.	<ol style="list-style-type: none"> <li>1. Power feeder roller height is set incorrectly.</li> </ol>	<ol style="list-style-type: none"> <li>1. Lower the power feeder roller 1/8" lower than the height of the workpiece.</li> </ol>



# Wheel Replacement

	<p><b>⚠ WARNING</b> Always disconnect power to the machine before performing maintenance. Failure to do this may result in serious personal injury.</p>
---	---

If you damage one or more wheels, you can easily replace the wheels.

Tools Needed	Qty
• Hex Wrench 5mm.....	1

### To replace a wheel:

1. DISCONNECT MACHINE FROM POWER!

2. Using a 5mm hex wrench, remove the two wheel retaining cap screws (see **Figure 21**).

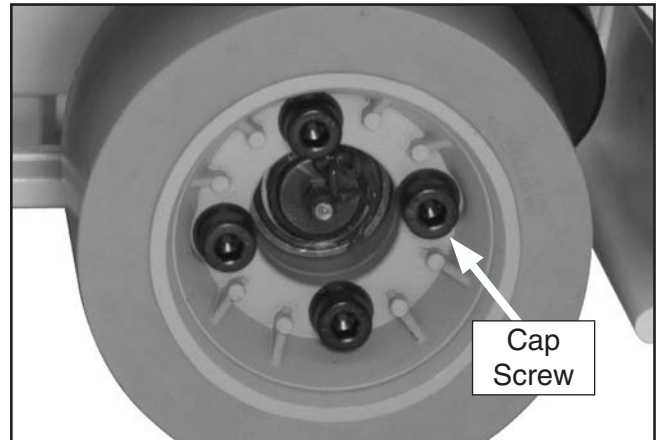

**Figure 21.** Wheel replacement.

3. Swap the old wheel with the new.
4. Re-install the two cap screws, and tighten in an alternating pattern until the wheel is secure.



# G4181 Wiring Diagram



View this page in color at [www.grizzly.com](http://www.grizzly.com).

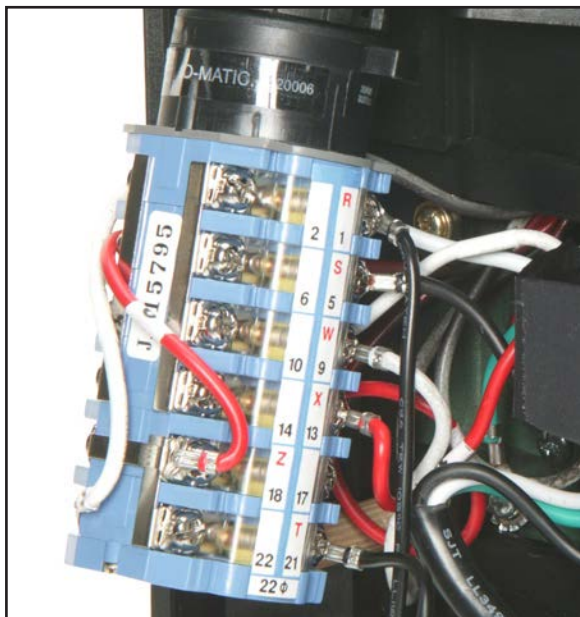
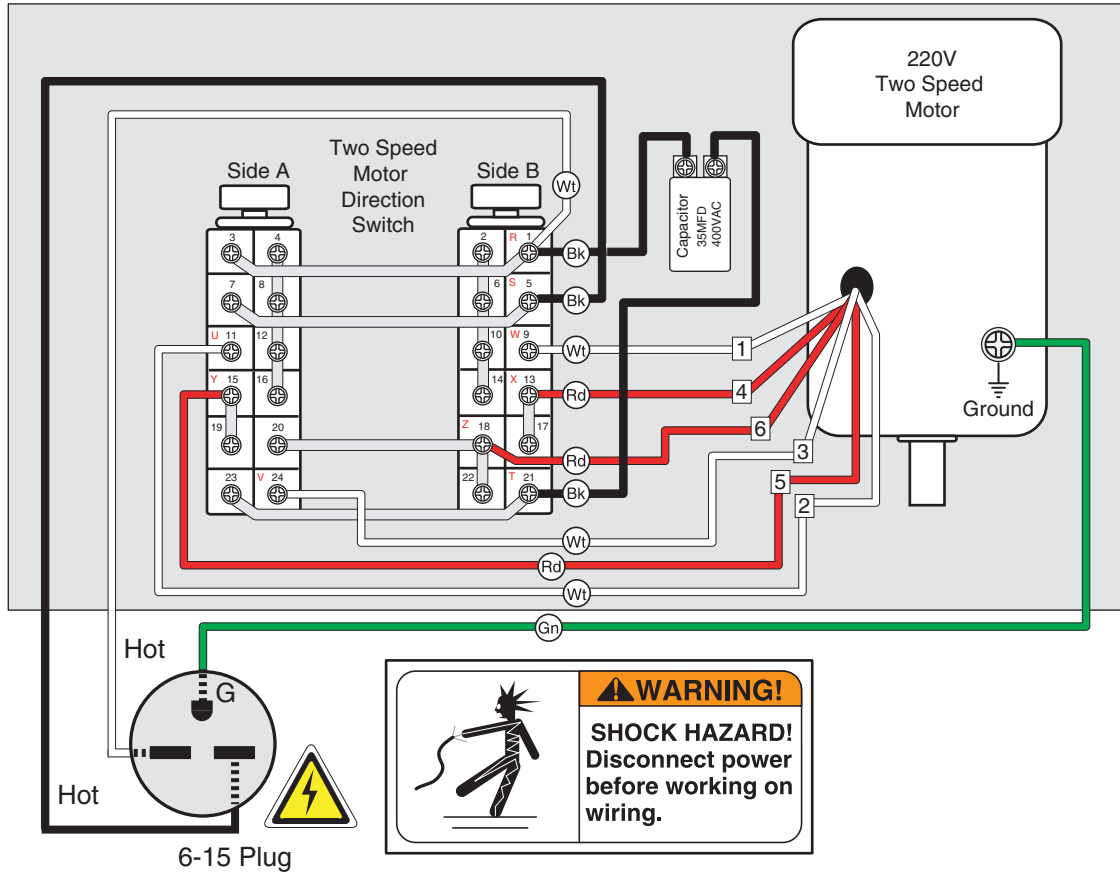

Figure 22. Motor power and direction switch.



Figure 23. Motor switch and capacitor.

# G7873 Wiring Diagram



View this page in color at [www.grizzly.com](http://www.grizzly.com).

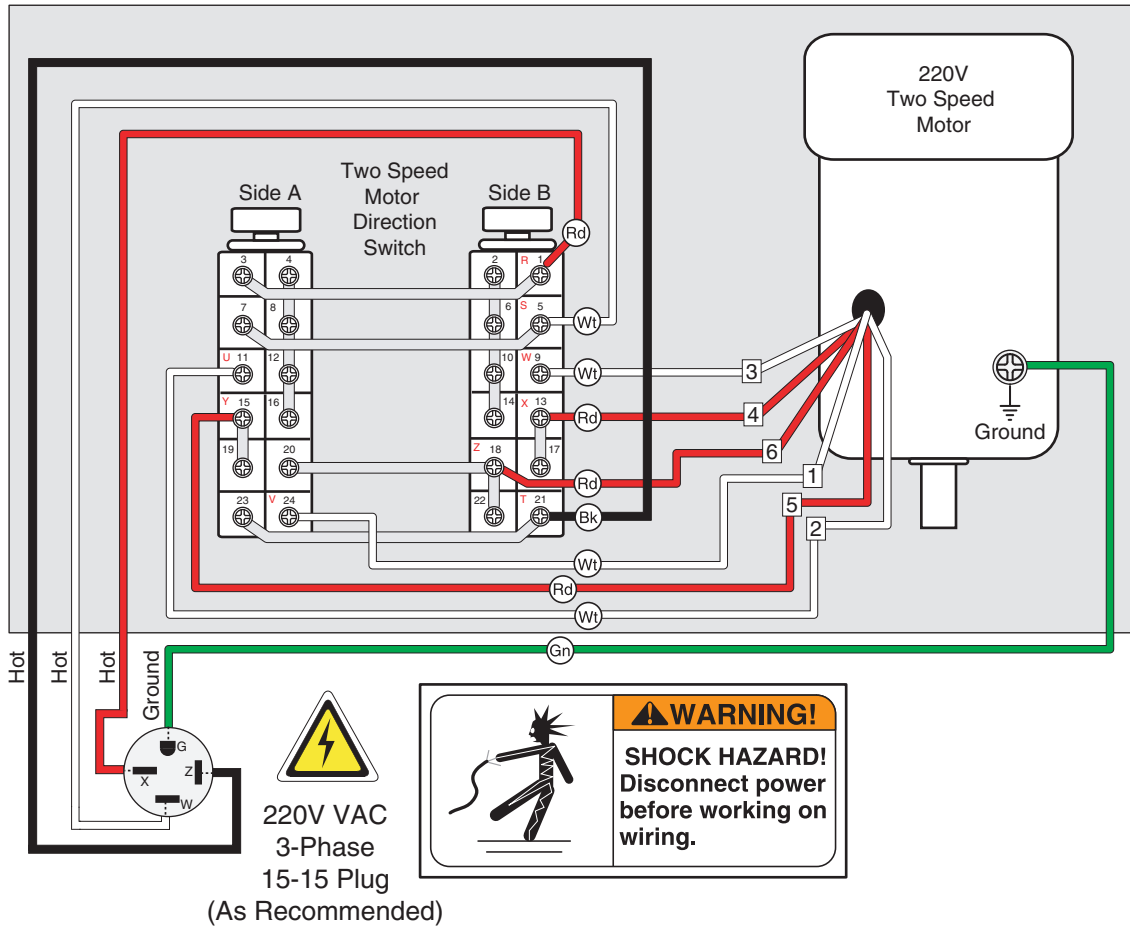

Figure 24. Motor switch (side view).



Figure 25. Motor switch (front view).





# Main Parts List

REF	PART #	DESCRIPTION
501	P4181501	WORM GEAR
502	P4181502	BUSHING
503	P4181503	GEAR 25T W/KEY
504	P4181504	CHAIN 26S
505	P4181505	STEEL TUBE
506	P4181506	SPROCKET SHAFT
507	P4181507	SPROCKET SHAFT W/ THREADS
508	P4181508	GREASE NIPPLE
509	P4181509	EXT RETAINING RING 24MM
510	P4181510	GEAR 40T W/KEY
511	P4181511	ROLLER SPINDLE
512	P4181512	CAP
514	P4181514	COVER
515	P4181515	CHAIN 62S
516	P4181516	DOUBLE SPROCKET
517	P4181517	CHAIN 40S
518	P4181518	KNOB
521	P4181521	OIL CAP ASSEMBLY
521-1	P4181521-1	OIL CAP
521-2	P4181521-2	O-RING 14.8 X 2.4 P15
522	P4181522	FRAME
522-1	P4181522-1	FRAME RING
526	P4181526	SPROCKET
528	P4181528	HEX NUT M12-1.75
529	P4181529	FLAT WASHER 12MM
530	P4181530	EXT RETAINING RING 13MM
531	P4181531	WORM GEAR BOX COVER ASSEMBLY
531-1	P4181531-1	O-RING 101.19 X 3.53MM
531-2	P4181531-2	GEAR BOX COVER
531-3	P4181531-3	OIL SEAL
536	P4181536	BALL BEARING 6203ZZ
538	P4181538	GREASE GUN
545	P4181545	MOTOR 1HP 220V 1-PH (G4181)
545-1	P4181545-1	FAN COVER
545-2	P4181545-2	FAN
545-3	P4181545-3	S CAPACITOR 35M 400V

REF	PART #	DESCRIPTION
545-4	P4181545-4	O-RING 69.4 X 3.1 G70
546	P4181546	COMPLETE SWITCH BOX ASSY
547	P4181547	COMPLETE SWITCH ASSY
550	P4181550	SET SCREW M6-1 X 10
552	P4181552	WHEEL
553	P4181553	BUSHING KEY
554	P4181554	EXT RETAINING RING 20MM
555	P4181555	SPROCKET CASE HEX BOLT M12-1.75
556	P4181556	LOCK WASHER 12MM
557	P4181557	CAP SCREW M6-1 X 16
558	P4181558	LOCK WASHER 6MM
559	P4181559	HEX BOLT M8-1.25 X 20
560	P4181560	LOCK WASHER 8MM
561	P4181561	GREASE NIPPLE
562	P4181562	SPROCKET CASE
563	P4181563	TORSION SPRING (B) 3.8 X 102
565	P4181565	GREASE NIPPLE
566	P4181566	SPROCKET CASE
567	P4181567	TORSION SPRING (A) 3.8 X 102
568	P4181568	CASE COVER
570	P4181570	ROLLER SUPPORT
571	P4181571	SPROCKET
576	P4181576	BUSHING
578	P4181578	CAP SCREW M5-.8 X 16
586	P4181586	CAP SCREW M5-.8 X 10
588	P4181588	O-RING 27.5 X 2.0 S28
589	P4181589	QC LABEL
590	P4181590	GENERAL WARNING LABEL
591	P4181591	COVER WARNING LABEL
592	P4181592	GRIZZLY LOGO PLATE
593	P4181593	SWITCH DIRECTION LABEL
594	P4181594	ELECTRICITY LABEL
595	P4181595	CAP SCREW M5-.8 X 20
596	P4181596	LOCK WASHER 5MM
599	P7873599	MOTOR 1HP 220V 3-PH (G7873)

**Please Note:** We do our best to stock replacement parts whenever possible, but we cannot guarantee that all parts shown here are available for purchase. Call (800) 523-4777 or visit our online parts store at [www.grizzly.com](http://www.grizzly.com) to check for availability.



# Base Breakdown

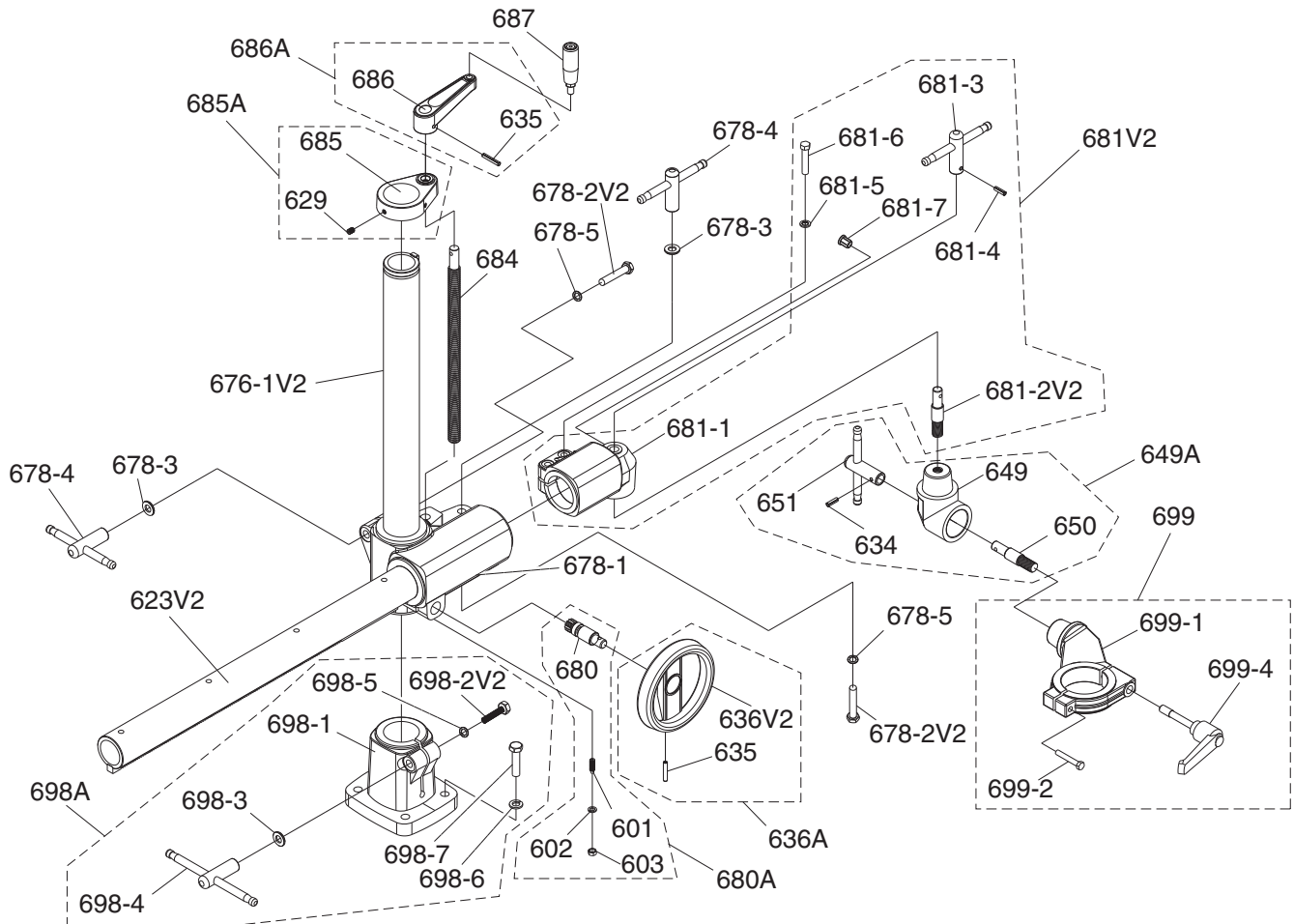

REF	PART #	DESCRIPTION
601	P4181601	SET SCREW M8-1.25 X 20
602	P4181602	LOCK WASHER 8MM
603	P4181603	HEX NUT M8-1.25
623V2	P4181623V2	OVER ARM 720MM V2.12.13
629	P4181629	SET SCREW M8-1.25 X 12
634	P4181634	ROLL PIN 6 x 22
635	P4181635	ROLL PIN 6 x 36
636A	P4181636A	HANDWHEEL ASSEMBLY
636V2	P4181636V2	HANDWHEEL W/O HANDLE V2.12.13
649A	P4181649A	SWIVEL CONE ASSEMBLY
649	P4181649	SWIVEL CONE
650	P4181650	MOTOR CLAMP CONNECTOR
651	P4181651	T-HANDLE
676-1V2	P4181676-1V2	VERTICAL COLUMN 560MM V2.12.13
678-1	P4181678-1	ELEVATING BRACKET
678-2V2	P4181678-2V2	HEX BOLT M12-1.75 X 75
678-3	P4181678-3	FLAT WASHER 12MM
678-4	P4181678-4	T-HANDLE W/THREADS
678-5	P4181678-5	INT TOOTH WASHER 12MM
680A	P4181680A	PINION ASSEMBLY
680	P4181680	PINION
681V2	P4181681V2	OVER ARM CONE ASSY V2.12.13
681-1	P4181681-1	OVER ARM CONE
681-2V2	P4181681-2V2	STANDOFF-HEX V2.12.13

REF	PART #	DESCRIPTION
681-3	P4181681-3	T-HANDLE W/HOLE FOR PIN
681-4	P4181681-4	ROLL PIN 6 X 22
681-5	P4181681-5	FLAT WASHER 10MM
681-6	P4181681-6	HEX BOLT M10-1.5 X 50
681-7	P4181681-7	STRAIN RELIEF
684	P4181684	ELEVATING SCREW M19-4 X 380
685A	P4181685A	COLUMN CAP ASSEMBLY
685	P4181685	COLUMN CAP
686A	P4181686A	CRANK ASSEMBLY
686	P4181686	CRANK
687	P4181687	HANDLE M10-1.5 X 70
698A	P4181698A	COLUMN BASE ASSEMBLY
698-1	P4181698-1	COLUMN BASE
698-2V2	P4181698-2V2	HEX BOLT M12-1.75 X 75
698-3	P4181698-3	FLAT WASHER 12MM
698-4	P4181698-4	T-HANDLE W/THREADS
698-5	P4181698-5	INT TOOTH WASHER 12MM
698-6	P4181698-6	LOCK WASHER 12MM
698-7	P4181698-7	HEX BOLT M12-1.75 X 50
699	P4181699	MOTOR CLAMP ASSEMBLY
699-1	P4181699-1	MOTOR CLAMP
699-2	P4181699-2	HEX BOLT M8-1.25 X 50
699-4	P4181699-4	LEVER





# WARRANTY CARD

Name \_\_\_\_\_  
 Street \_\_\_\_\_  
 City \_\_\_\_\_ State \_\_\_\_\_ Zip \_\_\_\_\_  
 Phone # \_\_\_\_\_ Email \_\_\_\_\_  
 Model # \_\_\_\_\_ Order # \_\_\_\_\_ Serial # \_\_\_\_\_

The following information is given on a voluntary basis. It will be used for marketing purposes to help us develop better products and services. **Of course, all information is strictly confidential.**

1. How did you learn about us?

Advertisement                       Friend                       Catalog  
 Card Deck                                 Website                       Other:

2. Which of the following magazines do you subscribe to?

<input type="checkbox"/> Cabinetmaker & FDM	<input type="checkbox"/> Popular Science	<input type="checkbox"/> Wooden Boat
<input type="checkbox"/> Family Handyman	<input type="checkbox"/> Popular Woodworking	<input type="checkbox"/> Woodshop News
<input type="checkbox"/> Hand Loader	<input type="checkbox"/> Precision Shooter	<input type="checkbox"/> Woodsmith
<input type="checkbox"/> Handy	<input type="checkbox"/> Projects in Metal	<input type="checkbox"/> Woodwork
<input type="checkbox"/> Home Shop Machinist	<input type="checkbox"/> RC Modeler	<input type="checkbox"/> Woodworker West
<input type="checkbox"/> Journal of Light Cont.	<input type="checkbox"/> Rifle	<input type="checkbox"/> Woodworker's Journal
<input type="checkbox"/> Live Steam	<input type="checkbox"/> Shop Notes	<input type="checkbox"/> Other:
<input type="checkbox"/> Model Airplane News	<input type="checkbox"/> Shotgun News	
<input type="checkbox"/> Old House Journal	<input type="checkbox"/> Today's Homeowner	
<input type="checkbox"/> Popular Mechanics	<input type="checkbox"/> Wood	

3. What is your annual household income?

\$20,000-\$29,000                       \$30,000-\$39,000                       \$40,000-\$49,000  
 \$50,000-\$59,000                       \$60,000-\$69,000                       \$70,000+

4. What is your age group?

20-29     30-39     40-49  
 50-59     60-69     70+

5. How long have you been a woodworker/metalworker?

0-2 Years                       2-8 Years                       8-20 Years                       20+ Years

6. How many of your machines or tools are Grizzly?

0-2                       3-5                       6-9                       10+

7. Do you think your machine represents a good value?     Yes                       No

8. Would you recommend Grizzly Industrial to a friend?     Yes                       No

9. Would you allow us to use your name as a reference for Grizzly customers in your area?

**Note:** We never use names more than 3 times.     Yes                       No

10. Comments: \_\_\_\_\_  
 \_\_\_\_\_  
 \_\_\_\_\_  
 \_\_\_\_\_

CUT ALONG DOTTED LINE

FOLD ALONG DOTTED LINE

\_\_\_\_\_
\_\_\_\_\_
\_\_\_\_\_



Place Stamp Here



GRIZZLY INDUSTRIAL, INC.
P.O. BOX 2069
BELLINGHAM, WA 98227-2069



FOLD ALONG DOTTED LINE

Send a Grizzly Catalog to a friend:

Name \_\_\_\_\_
Street \_\_\_\_\_
City \_\_\_\_\_ State \_\_\_\_\_ Zip \_\_\_\_\_

TAPE ALONG EDGES--PLEASE DO NOT STAPLE

# WARRANTY & RETURNS

---

---

Grizzly Industrial, Inc. warrants every product it sells for a period of **1 year** to the original purchaser from the date of purchase. This warranty does not apply to defects due directly or indirectly to misuse, abuse, negligence, accidents, repairs or alterations or lack of maintenance. This is Grizzly's sole written warranty and any and all warranties that may be implied by law, including any merchantability or fitness, for any particular purpose, are hereby limited to the duration of this written warranty. We do not warrant or represent that the merchandise complies with the provisions of any law or acts unless the manufacturer so warrants. In no event shall Grizzly's liability under this warranty exceed the purchase price paid for the product and any legal actions brought against Grizzly shall be tried in the State of Washington, County of Whatcom.

We shall in no event be liable for death, injuries to persons or property or for incidental, contingent, special, or consequential damages arising from the use of our products.

To take advantage of this warranty, contact us by mail or phone and give us all the details. We will then issue you a "Return Number," which must be clearly posted on the outside as well as the inside of the carton. We will not accept any item back without this number. Proof of purchase must accompany the merchandise.

The manufacturers reserve the right to change specifications at any time because they constantly strive to achieve better quality equipment. We make every effort to ensure that our products meet high quality and durability standards and we hope you never need to use this warranty.

Please feel free to write or call us if you have any questions about the machine or the manual.

Thank you again for your business and continued support. We hope to serve you again soon.

**grizzly.com**<sup>®</sup>  
**TOOL WEBSITE**

Buy Direct and Save with Grizzly<sup>®</sup> – Trusted, Proven and a Great Value!  
~Since 1983~

*Visit Our Website Today For  
Current Specials!*

**ORDER  
24 HOURS A DAY!  
1-800-523-4777**

