

Grizzly *Industrial, Inc.*®

MODEL G7943 G7944 12-SPEED DRILL PRESSES OWNER'S MANUAL *(For models manufactured since 09/17)*

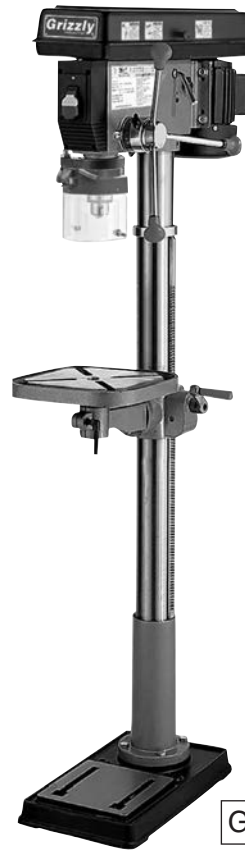

G7943



G7944



COPYRIGHT © 1992 BY GRIZZLY INDUSTRIAL, INC. REVISED MAY, 2018 (ABKB)
**WARNING: NO PORTION OF THIS MANUAL MAY BE REPRODUCED IN ANY SHAPE
OR FORM WITHOUT THE WRITTEN APPROVAL OF GRIZZLY INDUSTRIAL, INC.**
#BL3698 PRINTED IN CHINA

V3.05.18

 **WARNING!**

This manual provides critical safety instructions on the proper setup, operation, maintenance, and service of this machine/tool. Save this document, refer to it often, and use it to instruct other operators.

Failure to read, understand and follow the instructions in this manual may result in fire or serious personal injury—including amputation, electrocution, or death.

The owner of this machine/tool is solely responsible for its safe use. This responsibility includes but is not limited to proper installation in a safe environment, personnel training and usage authorization, proper inspection and maintenance, manual availability and comprehension, application of safety devices, cutting/sanding/grinding tool integrity, and the usage of personal protective equipment.

The manufacturer will not be held liable for injury or property damage from negligence, improper training, machine modifications or misuse.

 **WARNING!**

Some dust created by power sanding, sawing, grinding, drilling, and other construction activities contains chemicals known to the State of California to cause cancer, birth defects or other reproductive harm. Some examples of these chemicals are:

- Lead from lead-based paints.
- Crystalline silica from bricks, cement and other masonry products.
- Arsenic and chromium from chemically-treated lumber.

Your risk from these exposures varies, depending on how often you do this type of work. To reduce your exposure to these chemicals: Work in a well ventilated area, and work with approved safety equipment, such as those dust masks that are specially designed to filter out microscopic particles.

Table of Contents

INTRODUCTION	2	SECTION 5: ACCESSORIES	33
Contact Info.....	2	SECTION 6: MAINTENANCE	35
Machine Description	2	General	35
Manual Accuracy	2	Cleaning & Protecting	35
Identification.....	3	Lubrication	35
Controls & Components.....	4	V-Belts	35
G7943 Machine Data Sheet	5	SECTION 7: SERVICE	36
G7944 Machine Data Sheet	7	Troubleshooting	36
SECTION 1: SAFETY	9	Calibrating Depth Stop.....	38
Safety Instructions for Machinery	9	Tensioning Spindle Return Spring.....	38
Additional Safety for Drill Presses	11	SECTION 8: WIRING	40
SECTION 2: POWER SUPPLY	12	Wiring Safety Instructions	40
SECTION 3: SETUP	14	Electrical Components.....	41
Needed for Setup.....	14	G7943/G7944 Wiring Diagram	42
Unpacking	14	SECTION 9: PARTS	43
Inventory	15	G7943/G7944 Breakdown	43
Cleanup.....	16	G7943/G7944 Labels & Cosmetics	46
Site Considerations.....	17	WARRANTY AND RETURNS	49
Mounting G7943 to Bench.....	18		
Anchoring to Floor	18		
Mounting G7944 to Mobile Base	19		
Assembly	20		
Joining Drill Chuck & Arbor.....	24		
Test Run	25		
SECTION 4: OPERATIONS	26		
Operation Overview	26		
Choosing Speeds.....	27		
Changing Speeds	28		
Drilling	29		
Installing/Removing Drill Bits	30		
Depth Stop.....	30		
Positioning Table	31		
Removing Arbor.....	32		

INTRODUCTION

Contact Info

We stand behind our machines! If you have questions or need help, contact us with the information below. Before contacting, make sure you get the **serial number** and **manufacture date** from the machine ID label. This will help us help you faster.

Grizzly Technical Support
1815 W. Battlefield
Springfield, MO 65807
Phone: (570) 546-9663
Email: techsupport@grizzly.com

We want your feedback on this manual. What did you like about it? Where could it be improved? Please take a few minutes to give us feedback.

Grizzly Documentation Manager
P.O. Box 2069
Bellingham, WA 98227-2069
Email: manuals@grizzly.com

Machine Description

The G7943 and G7944 function and operate the same but have the following differences:

G7943

- Table Size..... 11³/₈" x 11³/₈"
- Max. Movement of Work Table..... 12¹/₂"
- Number of T-Slots 4
- Swing..... 14"
- Floor-to-Table Height..... 9¹/₂" – 22"
- Max. Distance From Spindle to Table..... 16"
- Spindle Taper MT#2

G7944

- Table Size..... 11³/₈" x 11³/₈"
- Max. Movement of Work Table..... 25³/₄"
- Number of T-Slots 4
- Swing..... 14"
- Floor-to-Table Height..... 20¹/₄ – 46"
- Max. Distance From Spindle to Table .. 31¹/₂"
- Spindle Taper MT#2

Manual Accuracy

We are proud to provide a high-quality owner's manual with your new machine!

We made every effort to be exact with the instructions, specifications, drawings, and photographs in this manual. Sometimes we make mistakes, but our policy of continuous improvement also means that **sometimes the machine you receive is slightly different than shown in the manual.**

If you find this to be the case, and the difference between the manual and machine leaves you confused or unsure about something, check our website for an updated version. We post current manuals and manual updates for free on our website at **www.grizzly.com**.

Alternatively, you can call our Technical Support for help. Before calling, make sure you write down the **Manufacture Date** and **Serial Number** from the machine ID label (see below). This information is required for us to provide proper tech support, and it helps us determine if updated documentation is available for your machine.

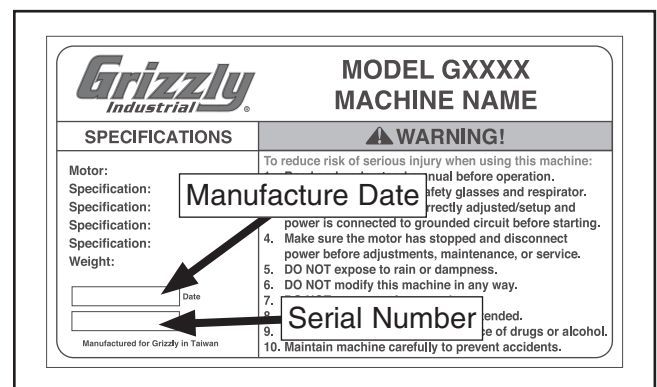

Identification

Become familiar with the names and locations of the controls and features shown below to better understand the instructions in this manual.

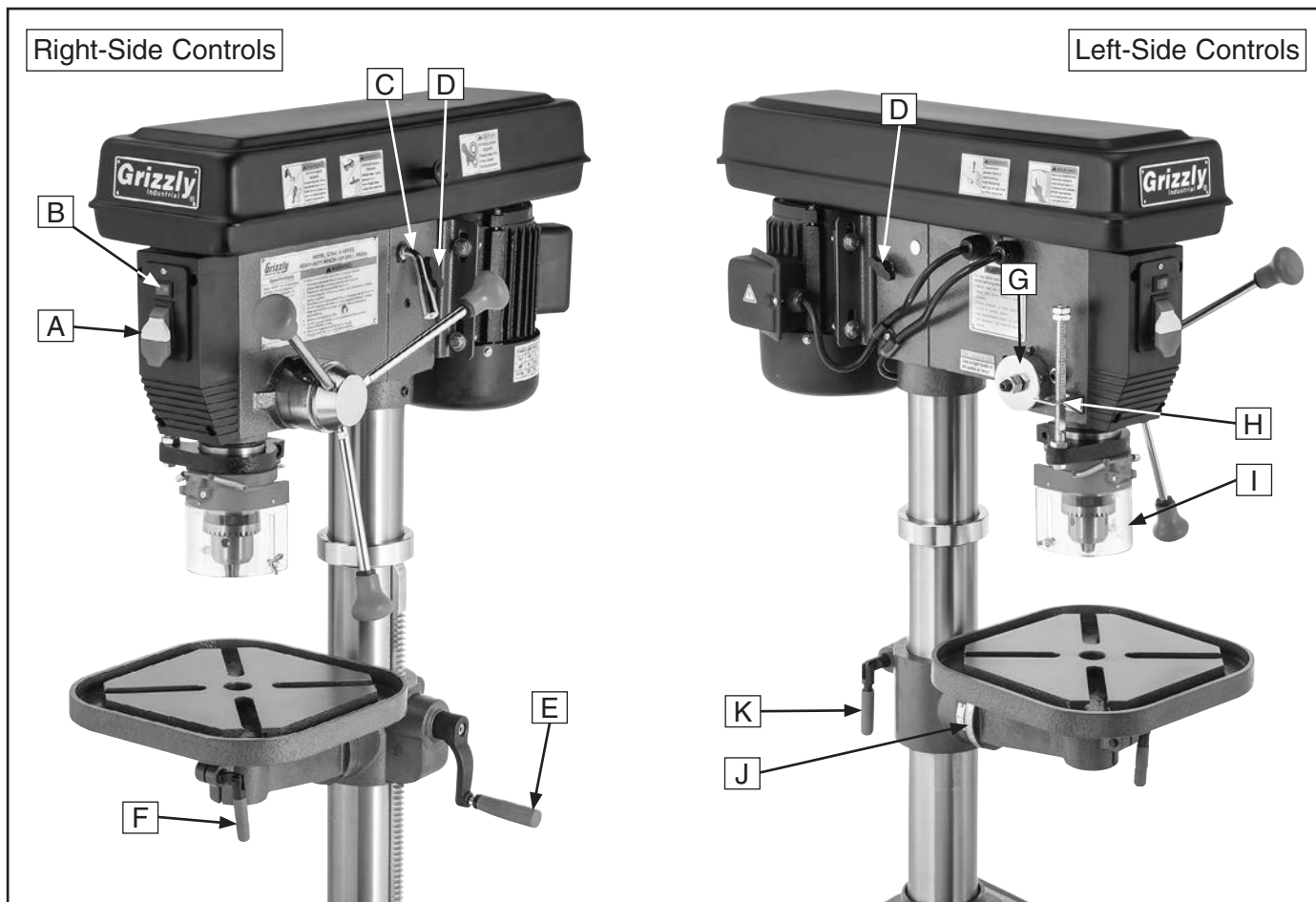

- A. ON/OFF Switch
- B. Light Switch
- C. Belt Tension Lever
- D. Belt Tension Lock
- E. Table Height Crank
- F. Table Rotation Lock Lever

- G. Spindle Return Spring
- H. Depth Stop
- I. Chuck Guard
- J. Scale
- K. Column Lock Lever

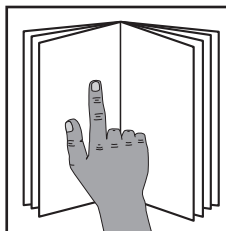

!WARNING

To reduce your risk of serious injury, read this entire manual **BEFORE** using machine.



Controls & Components

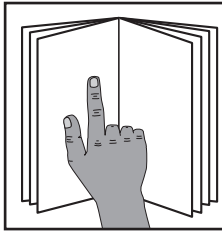

!WARNING

To reduce your risk of serious injury, read this entire manual **BEFORE** using machine.

Refer to the following figures and descriptions to become familiar with the basic controls and components of this machine. Understanding these items and how they work will help you understand the rest of the manual and minimize your risk of injury when operating this machine.

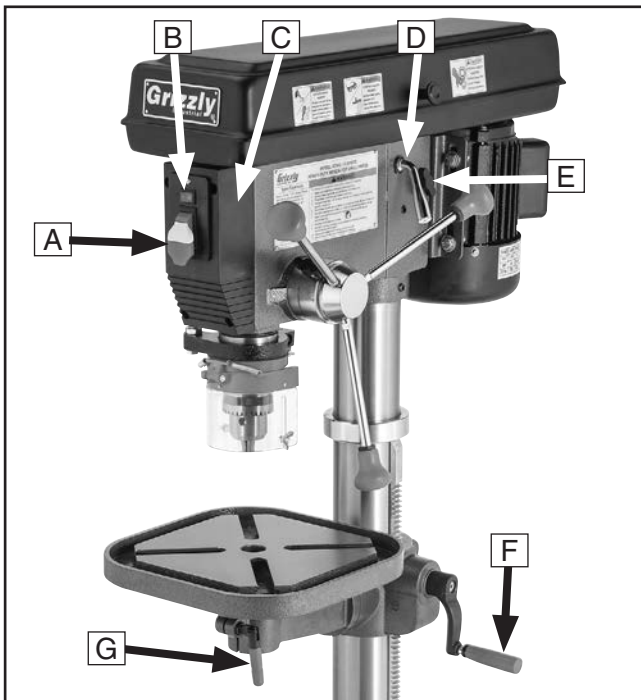

Figure 1. Headstock controls (right).

- A. **ON/OFF Switch:** Turns motor **ON/OFF**.
- B. **Light Switch:** Turns work light **ON/OFF**.
- C. **Headstock:** The cast-iron upper portion of the drill press, which houses the quill and work light, and supports the motor and belt housing.
- D. **Belt Tension Lever:** Adjusts motor location to increase/decrease belt tension.

- E. **Belt Tension Locks:** Two knobs on each side of headstock lock motor in place.
- F. **Table Height Crank:** Raises/lowers table.
- G. **Table Rotation Lock Lever:** Locks table rotation.

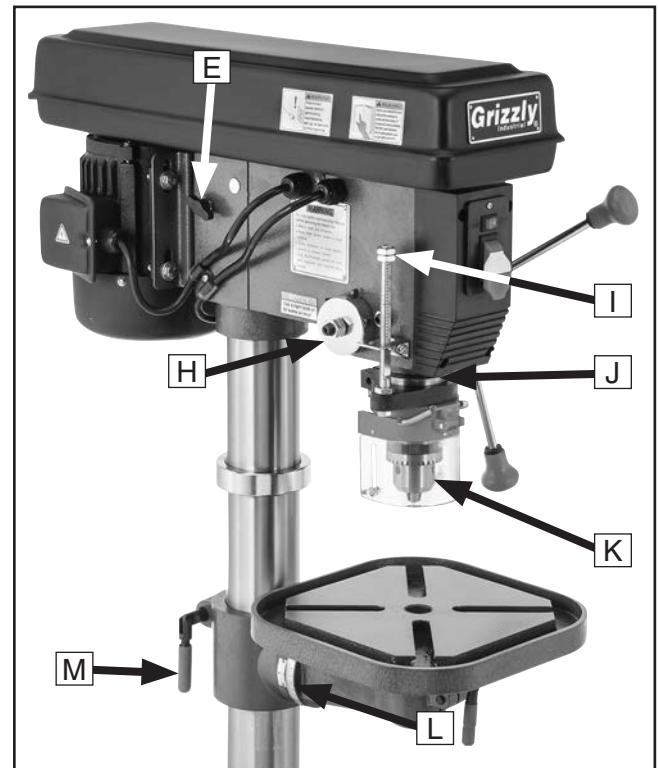

Figure 2. Headstock controls (left).

- H. **Spindle Return Spring:** Automatically returns quill into headstock.
- I. **Depth Stop:** Limits quill travel to a pre-set drilling depth.
- J. **Quill:** Houses the spindle and bearings.
- K. **Chuck:** Accepts drill bits with shanks from $\frac{3}{64}$ " to $\frac{5}{8}$ " and uses a JT-3 key.
- L. **Scale:** Displays current table-tilt angle.
- M. **Column Lock Lever:** Locks table height.





MACHINE DATA SHEET

Customer Service #: (570) 546-9663 · To Order Call: (800) 523-4777 · Fax #: (800) 438-5901

MODEL G7943 14" HEAVY-DUTY BENCHTOP DRILL PRESS

Product Dimensions:

Weight..... 133 lbs.
Width (side-to-side) x Depth (front-to-back) x Height..... 14-1/2 x 24 x 38 in.
Footprint (Length x Width)..... 18 x 11 in.

Shipping Dimensions:

Carton #1

Type..... Cardboard Box
Content..... Machine
Weight..... 84 lbs.
Length x Width x Height..... 30 x 18 x 12 in.
Must Ship Upright..... No

Carton #2

Type..... Cardboard Box
Content..... Base
Weight..... 64 lbs.
Length x Width x Height..... 33 x 26 x 9 in.
Must Ship Upright..... No

Electrical:

Power Requirement..... 120V, Single-Phase, 60 Hz
Prewired Voltage..... 120V
Full-Load Current Rating..... 7.5A
Minimum Circuit Size..... 15A
Connection Type..... Cord & Plug
Power Cord Included..... Yes
Power Cord Length..... 8-1/2 ft.
Power Cord Gauge..... 18 AWG
Plug Included..... Yes
Included Plug Type..... 5-15
Switch Type..... Paddle Safety Switch w/Removable Key

Motors:

Main

Horsepower..... 3/4 HP
Phase..... Single-Phase
Amps..... 7.5A
Speed..... 1725 RPM
Type..... TEFC Capacitor-Start Induction
Power Transfer V-Belt Drive
Bearings..... Shielded & Permanently Lubricated



Main Specifications:

Operation Information

Type.....	Bench
Swing.....	14 in.
Spindle Taper.....	MT#2
Spindle Travel.....	3-1/4 in.
Max. Distance From Spindle to Column.....	7 in.
Max. Distance From Spindle to Table.....	16 in.
Number of Spindle Speeds.....	12
Range of Spindle Speeds.....	140 – 3050 RPM
Max. Head Swivel.....	360 deg.
Drilling Capacity (Mild Steel).....	3/4 in. in Steel
Drill Chuck Type.....	JT33 Key Chuck
Drill Chuck Size.....	3/64 – 5/8 in.

Spindle Information

Distance From Spindle to Base.....	23 in.
Quill Diameter.....	2.040 in.

Table Information

Max. Table Tilt (Left/Right).....	90 deg.
Table Swing.....	360 deg.
Table Swivel Around Center.....	360 deg.
Table Swivel Around Column.....	360 deg.
Max. Movement of Work Table.....	12-1/2 in.
Table Length.....	11-3/8 in.
Table Width.....	11-3/8 in.
Table Thickness.....	1-1/4 in.
Vertical Table Travel.....	Crank Handle Operation
Number of T-Slots.....	4
T-Slot Size.....	1/2 in.
T-Slot Centers.....	3-7/8 in.
Floor-To-Table Height.....	9-1/2 – 22 in.

Construction

Table.....	Precision-Ground Cast Iron
Column.....	Steel
Spindle Housing.....	Cast Iron
Head.....	Cast Iron
Base.....	Cast Iron
Paint Type/Finish.....	Enamel

Other Related Information

Base Length.....	18 in.
Base Width.....	11 in.
Column Diameter.....	3.150 in.
Depth Stop Type.....	Threaded Rod with Positive Stop
Has Work Light.....	Yes
Light Socket Type.....	120V, Std Bulb
Maximum Bulb Wattage.....	60 W

Other Specifications:

Country of Origin	China
Warranty	1 Year
Approximate Assembly & Setup Time	45 Minutes
Serial Number Location	ID Label on Head
ISO 9001 Factory	Yes
Certified by a Nationally Recognized Testing Laboratory (NRTL)	Yes
Awards	Popular Woodworking Editor's Choice Tool Buying Guide





MACHINE DATA SHEET

Customer Service #: (570) 546-9663 · To Order Call: (800) 523-4777 · Fax #: (800) 438-5901

MODEL G7944 14" HEAVY-DUTY FLOOR DRILL PRESS

Product Dimensions:

Weight..... 146 lbs.
 Width (side-to-side) x Depth (front-to-back) x Height..... 14-1/2 x 24 x 64 in.
 Footprint (Length x Width)..... 18 x 11 in.

Shipping Dimensions:

Type..... Cardboard Box
 Content..... Machine
 Weight..... 156 lbs.
 Length x Width x Height..... 56 x 20 x 10 in.
 Must Ship Upright..... No

Electrical:

Power Requirement..... 120V, Single-Phase, 60 Hz
 Prewired Voltage..... 120V
 Full-Load Current Rating..... 7.5A
 Minimum Circuit Size..... 15A
 Connection Type..... Cord & Plug
 Power Cord Included..... Yes
 Power Cord Length..... 8-1/2 ft.
 Power Cord Gauge..... 18 AWG
 Plug Included..... Yes
 Included Plug Type..... 5-15
 Switch Type..... Paddle Safety Switch w/Removable Key

Motors:

Main

Horsepower..... 3/4 HP
 Phase..... Single-Phase
 Amps..... 7.5A
 Speed..... 1725 RPM
 Type..... TEFC Capacitor-Start Induction
 Power Transfer V-Belt Drive
 Bearings..... Shielded & Permanently Lubricated

Main Specifications:

Operation Information

Type..... Floor
 Swing..... 14 in.
 Spindle Taper..... MT#2
 Spindle Travel..... 3-1/4 in.
 Max. Distance From Spindle to Column..... 7 in.
 Max. Distance From Spindle to Table..... 31-1/2 in.
 Number of Spindle Speeds..... 12
 Range of Spindle Speeds..... 140 – 3050 RPM
 Max. Head Swivel..... 360 deg.
 Drilling Capacity (Mild Steel)..... 3/4 in.
 Drill Chuck Type..... JT33 Key Chuck
 Drill Chuck Size..... 3/64 – 5/8 in.



Spindle Information

Distance From Spindle to Base.....	49 in.
Quill Diameter.....	2.040 in.

Table Information

Max. Table Tilt (Left/Right).....	90 deg.
Table Swing.....	360 deg.
Table Swivel Around Center.....	360 deg.
Table Swivel Around Column.....	360 deg.
Max. Movement of Work Table.....	25-3/4 in.
Table Length.....	11-3/8 in.
Table Width.....	11-3/8 in.
Table Thickness.....	1-1/4 in.
Vertical Table Travel.....	Crank Handle Operation
Number of T-Slots.....	4
T-Slot Size.....	5/8 in.
T-Slot Centers.....	3-7/8 in.
Floor-To-Table Height.....	20-1/4 – 46 in.

Construction

Table.....	Precision-Ground Cast Iron
Column.....	Steel
Spindle Housing.....	Cast Iron
Head.....	Cast Iron
Base.....	Cast Iron
Paint Type/Finish.....	Enamel

Other Related Information

Base Length.....	18 in.
Base Width.....	11 in.
Mobile Base.....	D2260A
Column Diameter.....	3.150 in.
Depth Stop Type.....	Hub
Has Work Light.....	Yes
Light Socket Type.....	120V, Std Bulb
Maximum Bulb Wattage.....	60 W

Other Specifications:

Country of Origin	China
Warranty	1 Year
Approximate Assembly & Setup Time	45 Minutes
Serial Number Location	ID Label on Head
ISO 9001 Factory	Yes
Certified by a Nationally Recognized Testing Laboratory (NRTL)	Yes
Awards	Popular Woodworking Editor's Choice Tool Buying Guide

Features:

- Four T-Slots Accommodates 1/2" Clamping Kit
- Table and Base are Cast Iron
- 12 Speeds
- 3/4HP Motor
- Threaded Depth Stop
- 1/64" – 5/8" Chuck
- Crank Handle Operated Rack and Pinion Vertical Table Movement
- Cushioned Grip Quill Handles
- Table Has Lock Levers and Coolant Trough
- Includes Built-in Light



SECTION 1: SAFETY

For Your Own Safety, Read Instruction Manual Before Operating This Machine

The purpose of safety symbols is to attract your attention to possible hazardous conditions. This manual uses a series of symbols and signal words intended to convey the level of importance of the safety messages. The progression of symbols is described below. Remember that safety messages by themselves do not eliminate danger and are not a substitute for proper accident prevention measures. Always use common sense and good judgment.

⚠ DANGER Indicates an imminently hazardous situation which, if not avoided, **WILL** result in death or serious injury.

⚠ WARNING Indicates a potentially hazardous situation which, if not avoided, **COULD** result in death or serious injury.

⚠ CAUTION Indicates a potentially hazardous situation which, if not avoided, **MAY** result in minor or moderate injury. It may also be used to alert against unsafe practices.

NOTICE Alerts the user to useful information about proper operation of the machine to avoid machine damage.

Safety Instructions for Machinery

⚠ WARNING

OWNER'S MANUAL. Read and understand this owner's manual **BEFORE** using machine.

TRAINED OPERATORS ONLY. Untrained operators have a higher risk of being hurt or killed. Only allow trained/supervised people to use this machine. When machine is not being used, disconnect power, remove switch keys, or lock-out machine to prevent unauthorized use—especially around children. Make your workshop kid proof!

DANGEROUS ENVIRONMENTS. Do not use machinery in areas that are wet, cluttered, or have poor lighting. Operating machinery in these areas greatly increases the risk of accidents and injury.

MENTAL ALERTNESS REQUIRED. Full mental alertness is required for safe operation of machinery. Never operate under the influence of drugs or alcohol, when tired, or when distracted.

ELECTRICAL EQUIPMENT INJURY RISKS. You can be shocked, burned, or killed by touching live electrical components or improperly grounded machinery. To reduce this risk, only allow qualified service personnel to do electrical installation or repair work, and always disconnect power before accessing or exposing electrical equipment.

DISCONNECT POWER FIRST. Always disconnect machine from power supply **BEFORE** making adjustments, changing tooling, or servicing machine. This prevents an injury risk from unintended startup or contact with live electrical components.

EYE PROTECTION. Always wear ANSI-approved safety glasses or a face shield when operating or observing machinery to reduce the risk of eye injury or blindness from flying particles. Everyday eyeglasses are **NOT** approved safety glasses.



WARNING

WEARING PROPER APPAREL. Do not wear clothing, apparel or jewelry that can become entangled in moving parts. Always tie back or cover long hair. Wear non-slip footwear to reduce risk of slipping and losing control or accidentally contacting cutting tool or moving parts.

HAZARDOUS DUST. Dust created by machinery operations may cause cancer, birth defects, or long-term respiratory damage. Be aware of dust hazards associated with each workpiece material. Always wear a NIOSH-approved respirator to reduce your risk.

HEARING PROTECTION. Always wear hearing protection when operating or observing loud machinery. Extended exposure to this noise without hearing protection can cause permanent hearing loss.

REMOVE ADJUSTING TOOLS. Tools left on machinery can become dangerous projectiles upon startup. Never leave chuck keys, wrenches, or any other tools on machine. Always verify removal before starting!

USE CORRECT TOOL FOR THE JOB. Only use this tool for its intended purpose—do not force it or an attachment to do a job for which it was not designed. Never make unapproved modifications—modifying tool or using it differently than intended may result in malfunction or mechanical failure that can lead to personal injury or death!

AWKWARD POSITIONS. Keep proper footing and balance at all times when operating machine. Do not overreach! Avoid awkward hand positions that make workpiece control difficult or increase the risk of accidental injury.

CHILDREN & BYSTANDERS. Keep children and bystanders at a safe distance from the work area. Stop using machine if they become a distraction.

GUARDS & COVERS. Guards and covers reduce accidental contact with moving parts or flying debris. Make sure they are properly installed, undamaged, and working correctly BEFORE operating machine.

FORCING MACHINERY. Do not force machine. It will do the job safer and better at the rate for which it was designed.

NEVER STAND ON MACHINE. Serious injury may occur if machine is tipped or if the cutting tool is unintentionally contacted.

STABLE MACHINE. Unexpected movement during operation greatly increases risk of injury or loss of control. Before starting, verify machine is stable and mobile base (if used) is locked.

USE RECOMMENDED ACCESSORIES. Consult this owner's manual or the manufacturer for recommended accessories. Using improper accessories will increase the risk of serious injury.

UNATTENDED OPERATION. To reduce the risk of accidental injury, turn machine **OFF** and ensure all moving parts completely stop before walking away. Never leave machine running while unattended.

MAINTAIN WITH CARE. Follow all maintenance instructions and lubrication schedules to keep machine in good working condition. A machine that is improperly maintained could malfunction, leading to serious personal injury or death.

DAMAGED PARTS. Regularly inspect machine for damaged, loose, or mis-adjusted parts—or any condition that could affect safe operation. Immediately repair/replace BEFORE operating machine. For your own safety, DO NOT operate machine with damaged parts!

MAINTAIN POWER CORDS. When disconnecting cord-connected machines from power, grab and pull the plug—NOT the cord. Pulling the cord may damage the wires inside. Do not handle cord/plug with wet hands. Avoid cord damage by keeping it away from heated surfaces, high traffic areas, harsh chemicals, and wet/damp locations.

EXPERIENCING DIFFICULTIES. If at any time you experience difficulties performing the intended operation, stop using the machine! Contact our Technical Support at (570) 546-9663.



Additional Safety for Drill Presses

WARNING

Serious injury or death can occur from getting clothing, jewelry, or long hair entangled in rotating spindle or bit/cutting tool. Contact with rotating bit/cutting tool can result in severe cuts or amputation of fingers. Flying metal chips can cause blindness or eye injuries. Broken bits/cutting tools, unsecured workpieces, chuck keys, or other adjustment tools thrown from rotating spindle can strike nearby operator or bystanders with deadly force. To reduce the risk of these hazards, operator and bystanders **MUST** completely heed hazards and warnings below.

EYE/FACE/HAND PROTECTION. Flying chips created by drilling can cause eye injuries or blindness. Always wear a face shield in addition to safety glasses. Always keep hands and fingers away from drill bit/cutting tool. Avoid awkward hand positions, where a sudden slip could cause hand to move into bit/cutting tool.

AVOIDING ENTANGLEMENT. DO NOT wear loose clothing, gloves, or jewelry. Tie back long hair. Keep all guards in place and secure. Always allow spindle to stop on its own. DO NOT stop spindle using your hand or any other object.

REMOVING ADJUSTMENT TOOLS. Chuck key, wrenches, and other tools left on machine can become deadly projectiles when spindle is started. Remove all loose items or tools used on spindle immediately after use.

CORRECT SPINDLE SPEED. Using wrong spindle speed can cause bits/cutting tools to break and strike operator or bystanders. Follow recommended speeds and feeds for each size/type of bit/cutting tool and workpiece material.

SECURING BIT/CUTTING TOOL. Firmly secure bit/cutting tool in chuck so it cannot fly out of spindle during operation or startup.

DRILLING PREPARATION. To avoid loss of drilling control or bit breakage, only drill into a flat surface that is approximately perpendicular to bit. Clear table of all objects before starting spindle. Never start spindle with bit pressed against workpiece.

SECURING TABLE AND HEADSTOCK. To avoid loss of control leading to accidental contact with tool/bit, tighten all table and headstock locks before operating drill press.

WORKPIECE CONTROL. An unsecured workpiece may unexpectedly shift, spin out of control, or be thrown if bit/cutting tool “grabs” during operation. Clamp workpiece to table or in table-mounted vise, or brace against column to prevent rotation. NEVER hold workpiece by hand during operation. NEVER start machine with bit/cutting tool touching workpiece; allow spindle to gain full speed before drilling.

INSPECTING BIT/CUTTING TOOL. Damaged bits/cutting tools may break apart during operation and hit operator or bystanders. Dull bits/cutting tools increase cutting resistance and are more likely to grab and spin/throw workpiece. Always inspect bits/cutting tools for sharpness, chips, or cracks before each use. Replace dull, chipped, or cracked bits/cutting tools immediately.

WARNING

Like all machinery there is potential danger when operating this machine. Accidents are frequently caused by lack of familiarity or failure to pay attention. Use this machine with respect and caution to decrease the risk of operator injury. If normal safety precautions are overlooked or ignored, serious personal injury may occur.

CAUTION

No list of safety guidelines can be complete. Every shop environment is different. Always consider safety first, as it applies to your individual working conditions. Use this and other machinery with caution and respect. Failure to do so could result in serious personal injury, damage to equipment, or poor work results.



SECTION 2: POWER SUPPLY

Availability

Before installing the machine, consider the availability and proximity of the required power supply circuit. If an existing circuit does not meet the requirements for this machine, a new circuit must be installed. To minimize the risk of electrocution, fire, or equipment damage, installation work and electrical wiring must be done by an electrician or qualified service personnel in accordance with all applicable codes and standards.

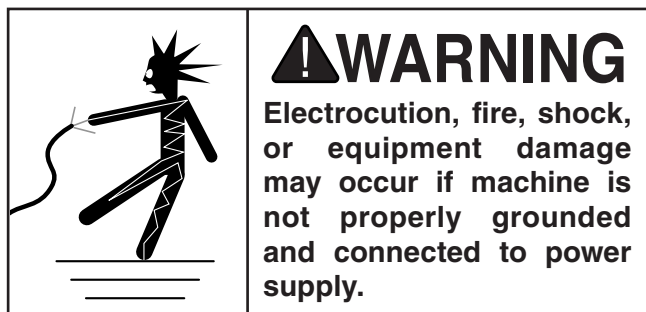

Full-Load Current Rating

The full-load current rating is the amperage a machine draws at 100% of the rated output power. On machines with multiple motors, this is the amperage drawn by the largest motor or sum of all motors and electrical devices that might operate at one time during normal operations.

Full-Load Current Rating at 120V ... 7.5 Amps

The full-load current is not the maximum amount of amps that the machine will draw. If the machine is overloaded, it will draw additional amps beyond the full-load rating.

If the machine is overloaded for a sufficient length of time, damage, overheating, or fire may result—especially if connected to an undersized circuit. To reduce the risk of these hazards, avoid overloading the machine during operation and make sure it is connected to a power supply circuit that meets the specified circuit requirements.

! WARNING

Serious injury could occur if you connect machine to power before completing setup process. DO NOT connect to power until instructed later in this manual.

110V Circuit Requirements

This machine is prewired to operate on a power supply circuit that has a verified ground and meets the following requirements:

Nominal Voltage 120V
Cycle 60 Hz
Phase Single-Phase
Power Supply Circuit 15 Amps

A power supply circuit includes all electrical equipment between the breaker box or fuse panel in the building and the machine. The power supply circuit used for this machine must be sized to safely handle the full-load current drawn from the machine for an extended period of time. (If this machine is connected to a circuit protected by fuses, use a time delay fuse marked D.)

! CAUTION

For your own safety and protection of property, consult an electrician if you are unsure about wiring practices or electrical codes in your area.

Note: *Circuit requirements in this manual apply to a dedicated circuit—where only one machine will be running on the circuit at a time. If machine will be connected to a shared circuit where multiple machines may be running at the same time, consult an electrician or qualified service personnel to ensure circuit is properly sized for safe operation.*



Grounding & Plug Requirements

This machine **MUST** be grounded. In the event of certain malfunctions or breakdowns, grounding reduces the risk of electric shock by providing a path of least resistance for electric current.

This machine is equipped with a power cord that has an equipment-grounding wire and a grounding plug. Only insert plug into a matching receptacle (outlet) that is properly installed and grounded in accordance with all local codes and ordinances. **DO NOT** modify the provided plug!

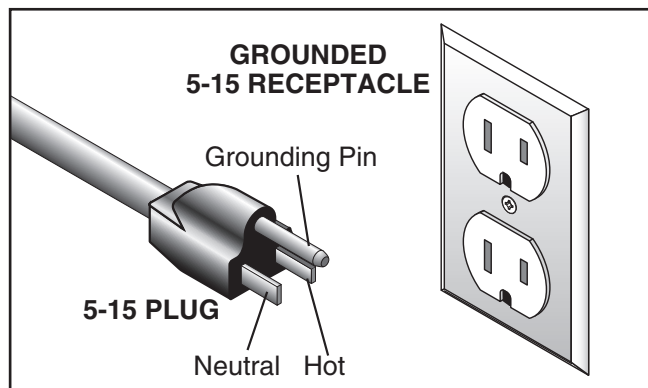

Figure 3. Typical 5-15 plug and receptacle.

⚠ CAUTION

SHOCK HAZARD!

Two-prong outlets do not meet the grounding requirements for this machine. Do not modify or use an adapter on the plug provided—if it will not fit the outlet, have a qualified electrician install the proper outlet with a verified ground.

Improper connection of the equipment-grounding wire can result in a risk of electric shock. The wire with green insulation (with or without yellow stripes) is the equipment-grounding wire. If repair or replacement of the power cord or plug is necessary, do not connect the equipment-grounding wire to a live (current carrying) terminal.

Check with a qualified electrician or service personnel if you do not understand these grounding requirements, or if you are in doubt about whether the tool is properly grounded. If you ever notice that a cord or plug is damaged or worn, disconnect it from power, and immediately replace it with a new one.

Extension Cords

We do not recommend using an extension cord with this machine. If you must use an extension cord, only use it if absolutely necessary and only on a temporary basis.

Extension cords cause voltage drop, which can damage electrical components and shorten motor life. Voltage drop increases as the extension cord size gets longer and the gauge size gets smaller (higher gauge numbers indicate smaller sizes).

Any extension cord used with this machine must be in good condition and contain a ground wire and matching plug/receptacle. Additionally, it must meet the following size requirements:

Minimum Gauge Size 14 AWG
Maximum Length (Shorter is Better).....50 ft.



SECTION 3: SETUP

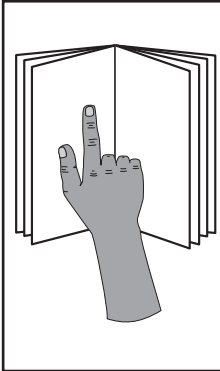

!WARNING

This machine presents serious injury hazards to untrained users. Read through this entire manual to become familiar with the controls and operations before starting the machine!

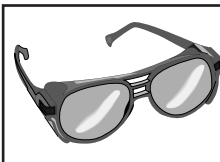

!WARNING

Wear safety glasses during the entire setup process!



!WARNING

HEAVY LIFT!

Straining or crushing injury may occur from improperly lifting machine or some of its parts. To reduce this risk, get help from other people and use a forklift (or other lifting equipment) rated for weight of this machine.

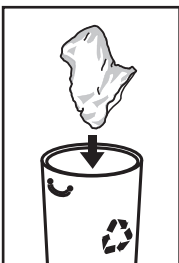

!WARNING

SUFFOCATION HAZARD!

Keep children and pets away from plastic bags or packing materials shipped with this machine.

Needed for Setup

The following items are needed to complete the set up process, but are not included with your machine:

Description	Qty
• Assistant for Lifting.....	1
• Safety Glasses (Per Person).....	1 Pr.
• Wrench or Socket 16mm.....	1
• Wrench or Socket 9/16".....	1
• Plumb Bob.....	1
• Rubber Mallet.....	1
• 60W Light Bulb.....	1
• Permanent Marker.....	1
• Ruler.....	1

Unpacking

This machine was carefully packaged for safe transport. When unpacking, separate all enclosed items from packaging materials and inspect them for shipping damage. ***If items are damaged, please call us immediately at (570) 546-9663.***

IMPORTANT: Save all packaging materials until you are completely satisfied with the machine and have resolved any issues between Grizzly or the shipping agent. ***You MUST have the original packaging to file a freight claim. It is also extremely helpful if you need to return your machine later.***



Inventory

The following is a list of items shipped with your machine. Before beginning setup, lay these items out and inventory them.

If any non-proprietary parts are missing (e.g. a nut or a washer), we will gladly replace them; or for the sake of expediency, replacements can be obtained at your local hardware store.

NOTICE

If you cannot find an item on this list, carefully check around/inside the machine and packaging materials. Often, these items get lost in packaging materials while unpacking or they are pre-installed at the factory.

Description	Qty
A. Table.....	1
B. Table Support Assembly	1
C. Small Lock Lever.....	1
D. Large Lock Lever.....	1
E. Crank Lever.....	1
F. Crank Handle	1
G. Column	1
H. Base	1
I. Lock Wrench	1
J. Downfeed Handles	3
K. Arbor.....	1
L. Drift Key.....	1
M. Chuck Key	1
N. Chuck	1
O. Headstock Assembly.....	1
P. Hardware Bag (Not Shown).....	1
—Belt Cover Knob	1
—Hex Wrench 3mm.....	1
—Hex Wrench 5mm.....	1
—Hex Bolt M10-1.5 x 25mm.....	4

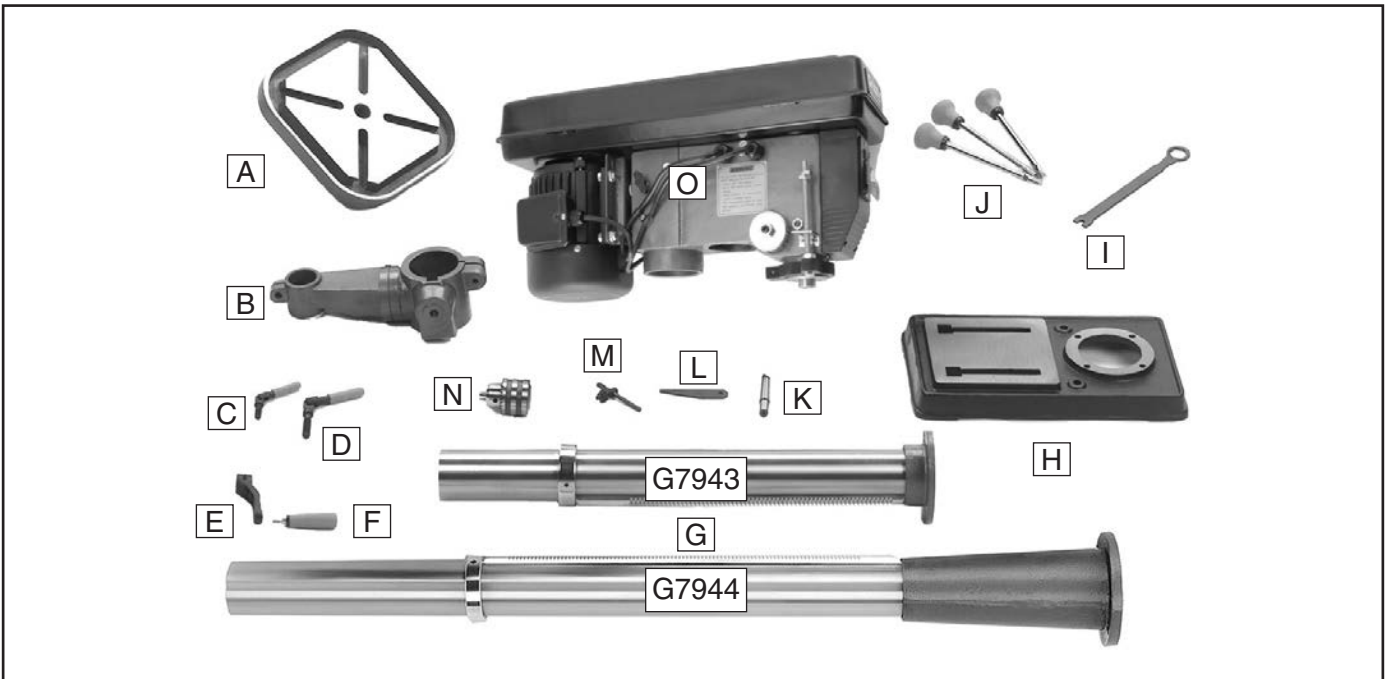

Figure 4. G7943/G7944 box inventory.



Cleanup

The unpainted surfaces of your machine are coated with a heavy-duty rust preventative that prevents corrosion during shipment and storage. This rust preventative works extremely well, but it will take a little time to clean.

Be patient and do a thorough job cleaning your machine. The time you spend doing this now will give you a better appreciation for the proper care of your machine's unpainted surfaces.

There are many ways to remove this rust preventative, but the following steps work well in a wide variety of situations. Always follow the manufacturer's instructions with any cleaning product you use and make sure you work in a well-ventilated area to minimize exposure to toxic fumes.

Before cleaning, gather the following:

- Disposable rags
- Cleaner/degreaser (WD•40 works well)
- Safety glasses & disposable gloves
- Plastic paint scraper (optional)

Basic steps for removing rust preventative:

1. Put on safety glasses.
2. Coat the rust preventative with a liberal amount of cleaner/degreaser, then let it soak for 5–10 minutes.
3. Wipe off the surfaces. If your cleaner/degreaser is effective, the rust preventative will wipe off easily. If you have a plastic paint scraper, scrape off as much as you can first, then wipe off the rest with the rag.
4. Repeat **Steps 2–3** as necessary until clean, then coat all unpainted surfaces with a quality metal protectant to prevent rust.

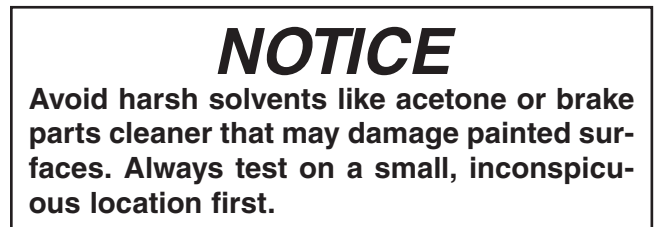
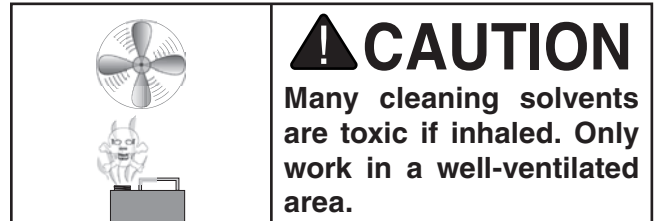
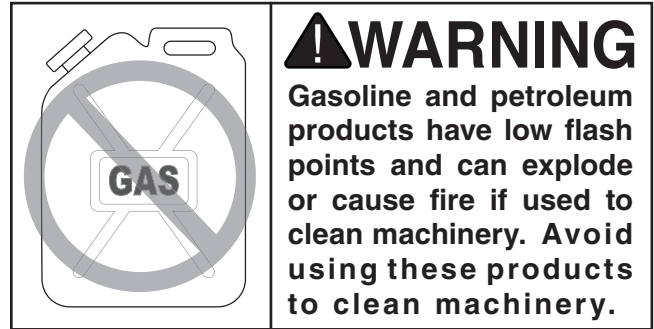

T23692—Orange Power Degreaser

A great product for removing the waxy shipping grease from the *non-painted* parts of the machine during clean up.



Figure 5. T23692 Orange Power Degreaser.



Site Considerations

Weight Load

Refer to the **Machine Data Sheet** for the weight of your machine. Make sure that the surface upon which the machine is placed will bear the weight of the machine, additional equipment that may be installed on the machine, and the heaviest workpiece that will be used. Additionally, consider the weight of the operator and any dynamic loading that may occur when operating the machine.

Space Allocation

Consider the largest size of workpiece that will be processed through this machine and provide enough space around the machine for adequate operator material handling or the installation of auxiliary equipment. With permanent installations, leave enough space around the machine to open or remove doors/covers as required by the maintenance and service described in this manual. **See below for required space allocation.**

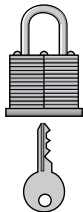
	<p>CAUTION Children or untrained people may be seriously injured by this machine. Only install in an access restricted location.</p>
---	---

Physical Environment

The physical environment where the machine is operated is important for safe operation and longevity of machine components. For best results, operate this machine in a dry environment that is free from excessive moisture, hazardous chemicals, airborne abrasives, or extreme conditions. Extreme conditions for this type of machinery are generally those where the ambient temperature range exceeds 41°–104°F; the relative humidity range exceeds 20%–95% (non-condensing); or the environment is subject to vibration, shocks, or bumps.

Electrical Installation

Place this machine near an existing power source. Make sure all power cords are protected from traffic, material handling, moisture, chemicals, or other hazards. Make sure to leave enough space around machine to disconnect power supply or apply a lockout/tagout device, if required.

Lighting

Lighting around the machine must be adequate enough that operations can be performed safely. Shadows, glare, or strobe effects that may distract or impede the operator must be eliminated.

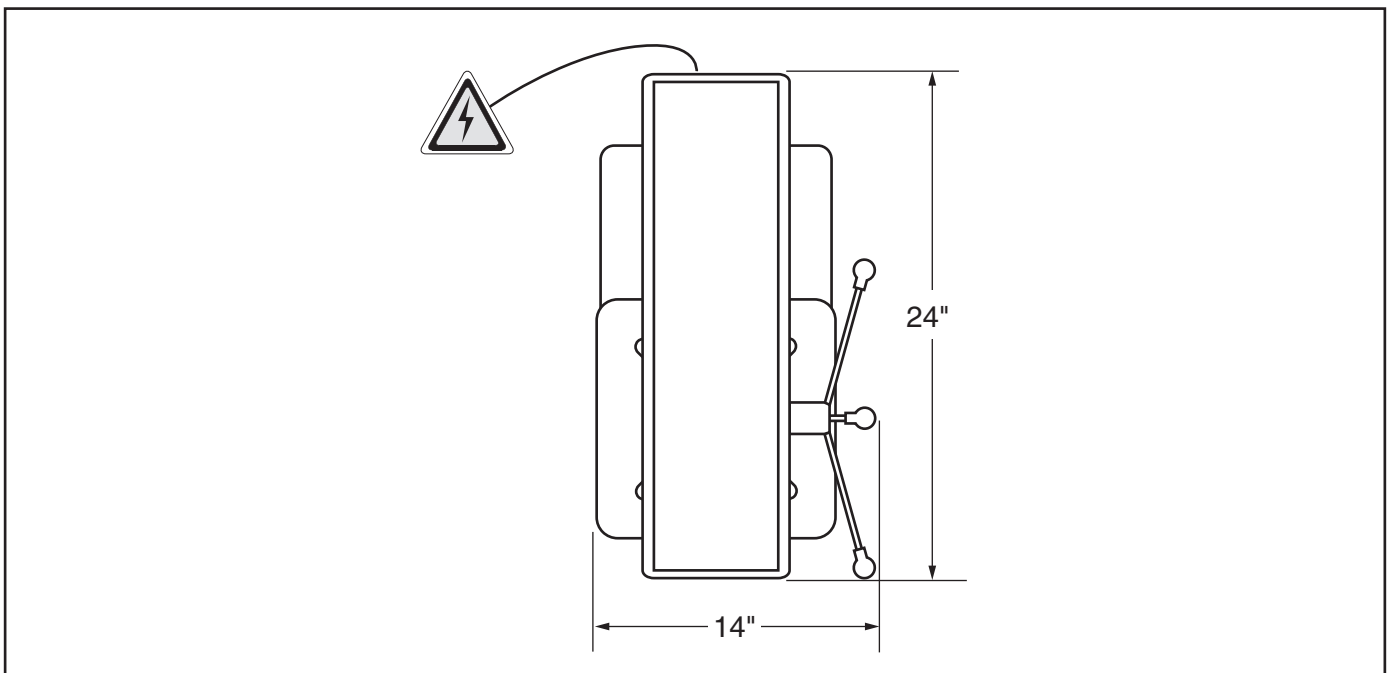

Figure 6. G7943/G7944 working clearances.



Mounting G7943 to Bench

The Model G7943 should be secured to a bench.

Items Needed	Qty
Assembled Drill Press	1
Diameter of Mounting Hardware	1/2"
Number of Mounting Holes	4

To mount the G7943 drill press to a bench:

1. Clamp the base on a bench top capable of holding approximately 100 lbs. plus the weight of the workpiece using two clamps. Make sure the surface is flat and stable.
2. Using holes in the base as a guide (see **Figure 7**), drill and bolt the base to the bench top using 1/2" lag bolts, or hex bolts, flat washers, and hex nuts.

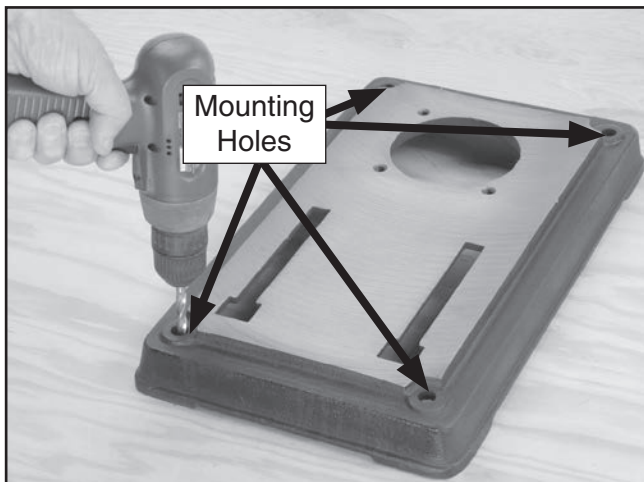

Figure 7. Using holes as a drilling guide.

Anchoring to Floor

Number of Mounting Holes	4
Diameter of Mounting Hardware.....	1/2"

Anchoring machinery to the floor prevents tipping or shifting and reduces vibration that may occur during operation, resulting in a machine that runs slightly quieter and feels more solid.

If the machine will be installed in a commercial or workplace setting, or if it is permanently connected (hardwired) to the power supply, local codes may require that it be anchored to the floor.

If not required by any local codes, fastening the machine to the floor is an optional step. If you choose not to do this with your machine, we recommend placing it on machine mounts, as these provide an easy method for leveling and they have vibration-absorbing pads.

Anchoring to Concrete Floors

Lag shield anchors with lag screws (see below) are a popular way to anchor machinery to a concrete floor, because the anchors sit flush with the floor surface, making it easy to unbolt and move the machine later, if needed. However, anytime local codes apply, you **MUST** follow the anchoring methodology specified by the code.

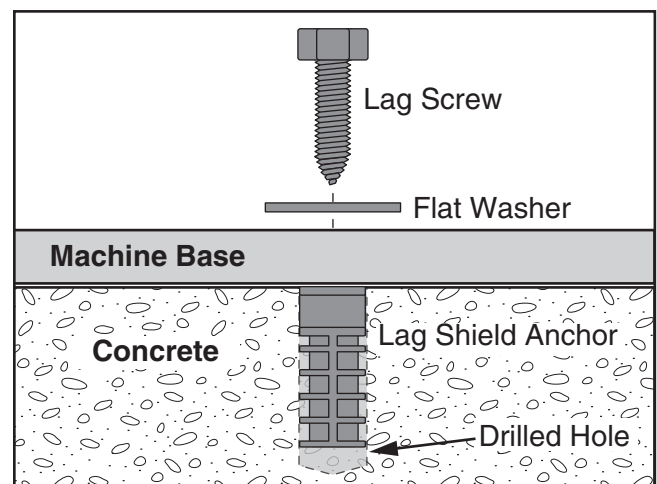

Figure 8. Popular method for anchoring machinery to a concrete floor.



Mounting G7944 to Mobile Base

Because the drill press is top-heavy by nature, we recommend mounting it to the floor, rather than a mobile base.

If you must use a mobile base, ALWAYS mount your drill press to a base plate inside of the mobile base, as shown in **Figure 9**.

A good quality base plate increases the standard footprint of the drill press to make it much more stable. The base plate must be at least 1½" thick and made of plywood (do not use OSB, MDF, or particle board) to hold the weight of the drill press. A common way for making the baseplate is described in this sub-section.

Always use extreme care when moving the drill press around with the mobile base!

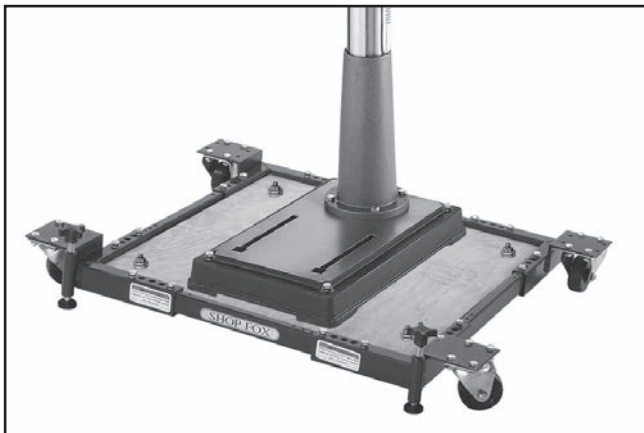

Figure 9. Drill press mounted on mobile base, using a base plate for support.

⚠ CAUTION

Drill presses are top-heavy and must be securely attached to a large-footprint base plate when used with a mobile base. Failure to use a base plate greatly increases possibility of tipping and personal injury.

Items Needed	Qty
Plywood ¾" x 23¾" x 23¾"	2
Wood Glue.....	As Needed
Wood Screws #6 x 1¼"	24
Hex Bolts (2¼" Long, Sized for Base Plate).....	4
Hex Nuts (Sized for Hex Bolts).....	4
Lock Washers (Sized for Hex Bolts).....	4
Flat Washers (Sized for Hex Bolts)	8
Assistant to Lift Drill Press	1

To make and use the base plate:

1. Glue the two pieces of plywood together, aligning edges and corners to make one thick piece.
2. Use wood screws to secure boards together from both sides.
3. Allow 24 hours for glue to dry before mounting drill press.
4. Place plywood base plate on mobile base.
5. Drill holes through base plate and metal plates at mobile base corners.
6. Secure base plate to mobile base with hex bolts, hex nuts, flat washers and lock washers, as shown in **Figure 10**.

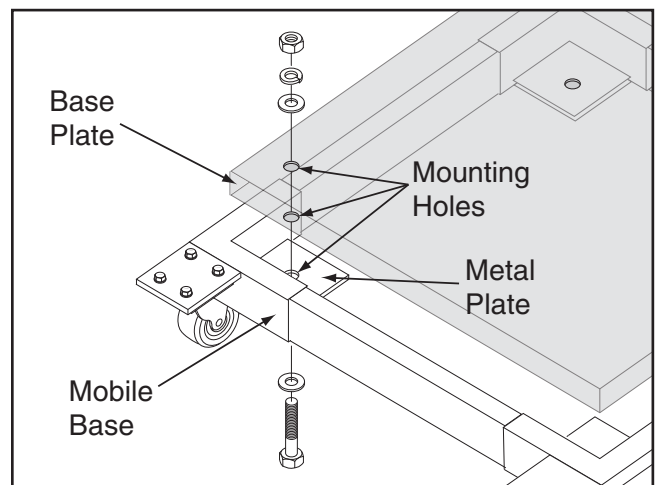

Figure 10. Mounting base plate to mobile base.



7. With help of an assistant, place drill press on base plate.
8. Position drill press close to front of mobile base, so mobile base will not become a tripping hazard.
9. Mount drill press to base plate with lag bolts and flat washers, as shown in **Figure 11**, or with through bolts, flat washers, and hex nuts.

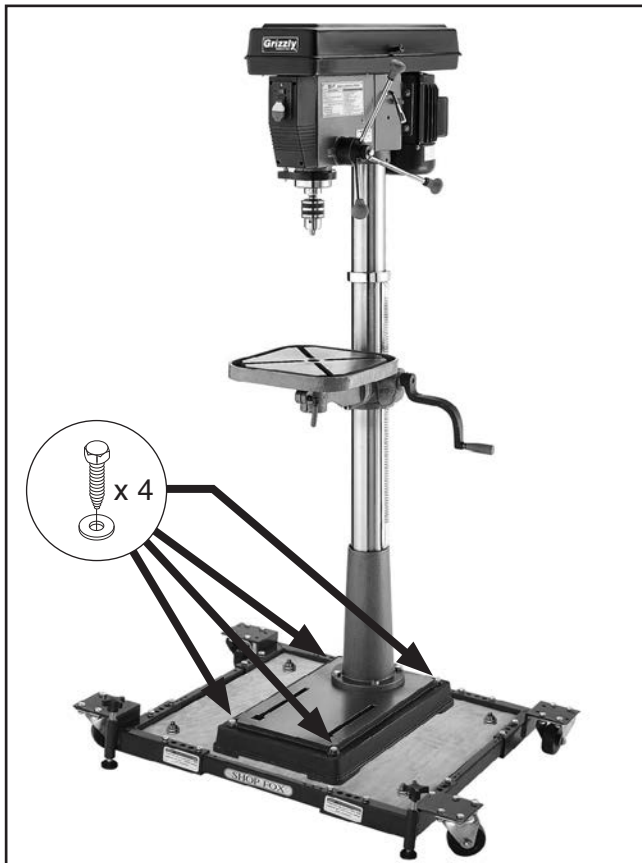

Figure 11. Drill press bolted to mobile base, using lag bolts and flat washers.

Assembly

The machine must be fully assembled before it can be operated. Before beginning the assembly process, refer to **Needed for Setup** and gather all listed items. To ensure the assembly process goes smoothly, first clean any parts that are covered or coated in heavy-duty rust preventative (if applicable).

The column must be secured on the base to properly assemble your drill press.

To assemble the machine:

1. Place column on base and align mounting holes.
2. Secure column to base with (4) hex bolts, as shown in **Figure 12**.

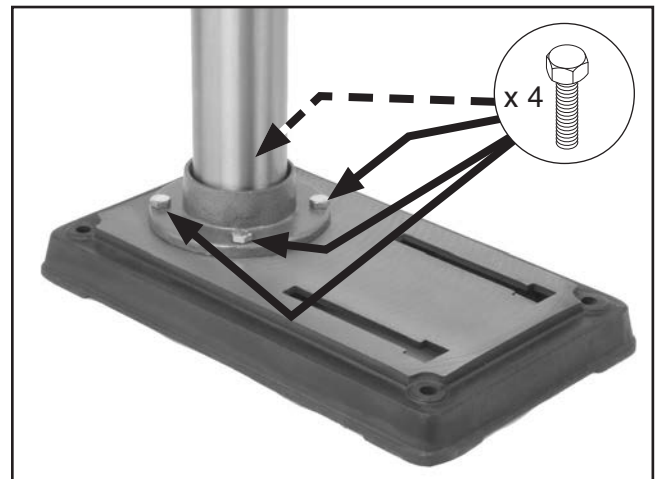

Figure 12. Column secured to base.



3. Place pinion in table support, as shown in **Figure 13**, so pinion and gear teeth mesh together.

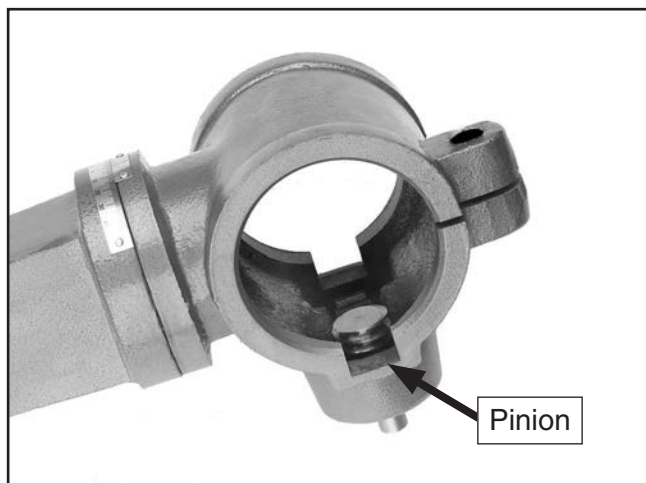

Figure 13. Pinion correctly installed in table support.

4. Mark top of rack, as shown in **Figure 14**, to keep track of which end is up.

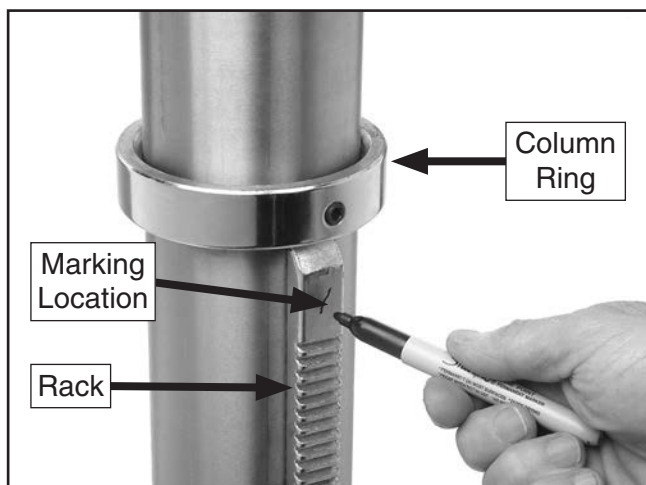

Figure 14. Marking top of rack to show which end is up.

5. Remove column ring by loosening set screw, and remove rack.

6. Place rack inside of table support assembly, mesh it with pinion, and slide table support/rack assembly over column, as shown in **Figure 15**.



Figure 15. Sliding table support and rack over the column.

7. Slide column ring over column with beveled edge facing down, as shown in **Figure 16**, then fit beveled edge of column ring over rack and tighten set screw.

Note: Do not overtighten the set screw or you may split the column ring. Also make sure the rack is seated firmly in the lower ring.



Figure 16. Correct column ring orientation.

8. Install crank lever over pinion shaft, and tighten set screw in crank handle against flat part of pinion shaft.
9. Thread handle into crank lever.
10. Thread large lock lever into back of table support assembly approximately three turns, for now.



11. Thread small lock lever into front part of table support assembly approximately three turns, for now. The assembly should match what is shown in **Figure 17**.

Note: For Model G7943, perform **Steps 12–13**, then proceed to **Step 17** to complete assembly. For Model G7944, proceed to **Step 14** to complete assembly.

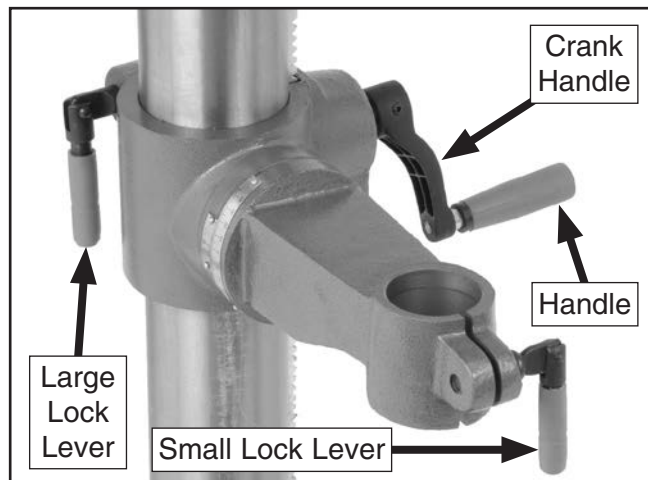



Figure 17. Handles and lock levers installed.



! WARNING
 The headstock is very heavy. You **MUST** have assistance when moving, lifting or mounting the headstock on the column and base assembly.

12. (Model G7943): Loosen (2) set screws on right side of headstock enough so they are flush with inside pocket of headstock.

NOTICE

Do **NOT** force the headstock onto the column! If you do, you could damage the headstock and the column.

13. With an assistant, lift the headstock assembly above the column, and gently slide it down the column as far as it will go.
14. (Model G7944): Set top piece of headstock Styrofoam packing approximately 6 feet away from column/base assembly.

15. Remove headstock from box and place it on Styrofoam packing you laid out in **Step 14**.

Note: To avoid damaging machine, be careful not to hold the headstock by the switch or the top part of the belt cover when lifting.

16. Carefully lay column/base on its side.
17. Slide column all the way into bottom of headstock (approximately 4"-6").

! CAUTION

If the base starts to slide when tilting, you **MUST** have a third person hold the base from sliding to avoid personal injury or machine damage.

18. Tilt entire assembly up (see **Figure 18**) and carefully position drill press on its base in the fully upright position.

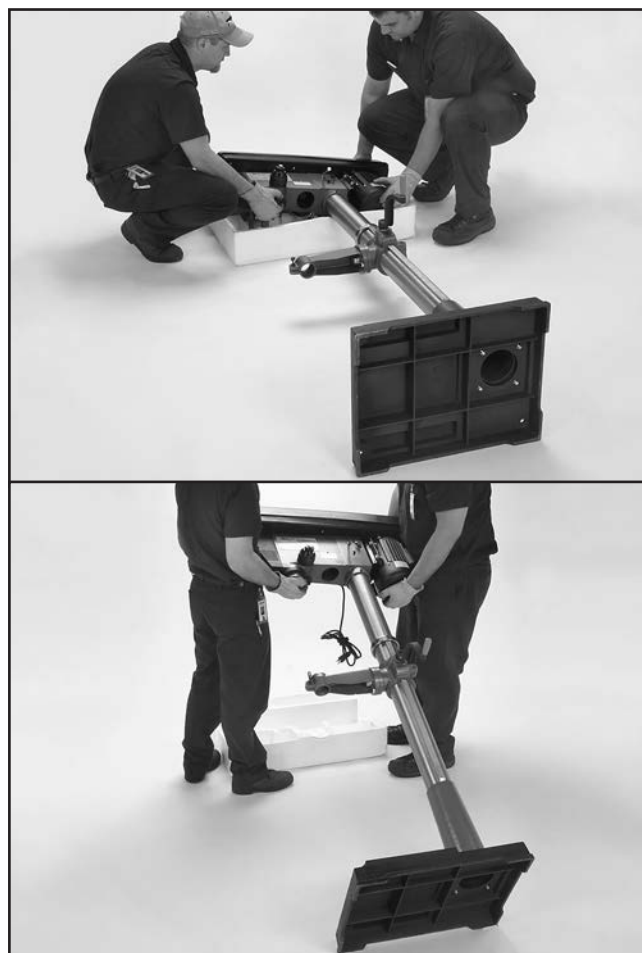

Figure 18. Tilting G7944 drill press upright.



19. Suspend a plumb bob from center of headstock spindle so it is over tape/ruler as shown in **Figure 19**.

20. Center headstock directly over base as indicated by plumb bob and ruler (see **Figure 19**).

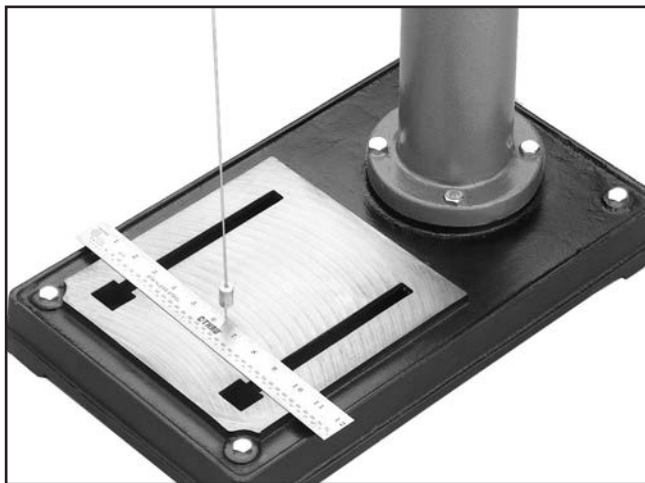

Figure 19. Aligning headstock with base.

21. Tighten (2) headstock set screws to column, as shown in **Figure 20**.



Figure 20. Securing headstock to column.

22. To install chuck guard, place chuck guard over flange of depth gauge mount, as shown in **Figure 21**, then tighten Phillips head screw and hex nut to secure it.

Note: To prevent the guard from slipping off, move the table up to support it. Or, have an assistant hold the guard in place while you secure it.

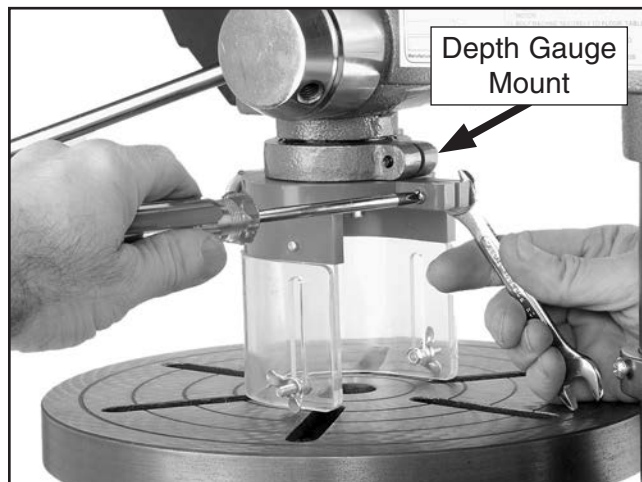

Figure 21. Installing chuck guard assembly.

23. Thread handles into spindle hub, as shown in **Figure 22**, and tighten.

24. Remove screw that fastens belt cover in place and replace with belt cover knob (see **Figure 22** for location).

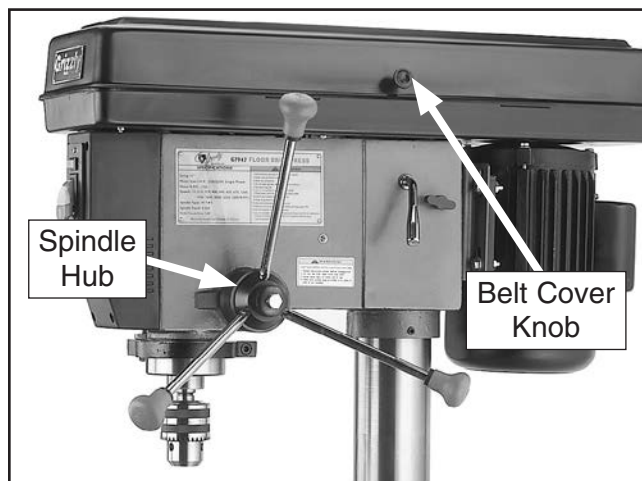

Figure 22. Downfeed handles and belt cover knob installed.



25. Insert table shaft into table support assembly.
26. Tighten small locking lever to secure table in table support assembly. The table should now be installed, as shown in **Figure 23**.



Figure 23. Table installed (G7943 shown).

27. Remove dust plug from light socket.
28. Install a 60W or smaller light bulb in location shown in **Figure 24**.

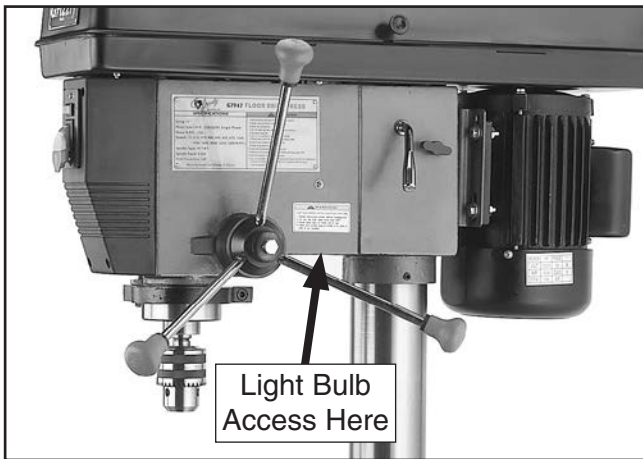

Figure 24. Light bulb access location.

⚠ WARNING

Use only bulbs that are “safety coated” and shatter resistant. The bulb will be exposed at the bottom of the head casting which helps with illumination. Impacts with a bulb not “safety coated” may shatter, exposing the electrical filaments and creating an electrical shock hazard.

Joining Drill Chuck & Arbor

An arbor is included for the drill chuck that comes with this machine. The following procedure describes how to install the arbor in the chuck.

After the arbor is installed in the drill chuck, it is very difficult to separate the assembly. If you would like to use a different chuck in the future, we recommend obtaining a new arbor.

IMPORTANT: DO NOT install the drill chuck and arbor assembly into the spindle until **AFTER** the test run.

To join drill chuck and arbor:

1. Use acetone or lacquer thinner to clean drill chuck and arbor mating surfaces, especially the bore.
2. Retract chuck jaws completely into chuck.
3. Insert small end of arbor into chuck.
4. Hold assembly by the arbor and tap chuck onto a block of wood with medium force, as illustrated below.

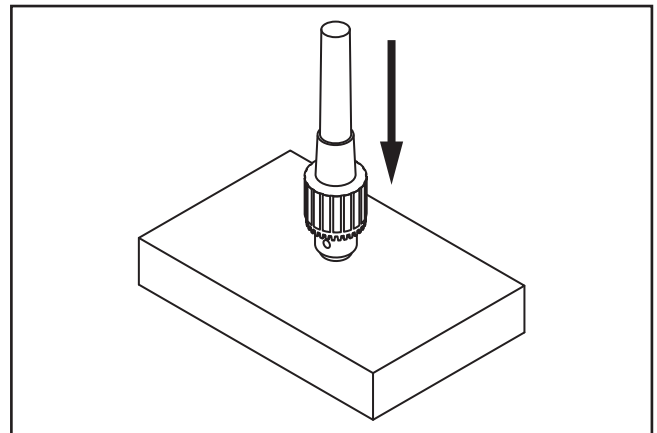

Figure 25. Tapping drill chuck/arbor on block of wood.

5. Attempt to separate drill chuck and arbor by hand—if they separate, repeat **Steps 3–4**.



Test Run

Once assembly is complete, test run the machine to ensure it is properly connected to power and safety components are functioning correctly.

If you find an unusual problem during the test run, immediately stop the machine, disconnect it from power, and fix the problem **BEFORE** operating the machine again. The **Troubleshooting** table in the **SERVICE** section of this manual can help.

The Test Run consists of verifying the following:
1) The motor powers up and runs correctly, and
2) the safety disabling mechanism on the switch works correctly.

!WARNING

Serious injury or death can result from using this machine BEFORE understanding its controls and related safety information. DO NOT operate, or allow others to operate, machine until the information is understood.

!WARNING

DO NOT start machine until all preceding setup instructions have been performed. Operating an improperly set up machine may result in malfunction or unexpected results that can lead to serious injury, death, or machine/property damage.

To test run the machine:

1. Clear all setup tools away from machine.
2. Connect machine to power supply.
3. Turn machine **ON**, verify motor operation, and then turn machine **OFF**.

The motor should run smoothly and without unusual problems or noises.

4. Remove switch disabling key, as shown in **Figure 26**.

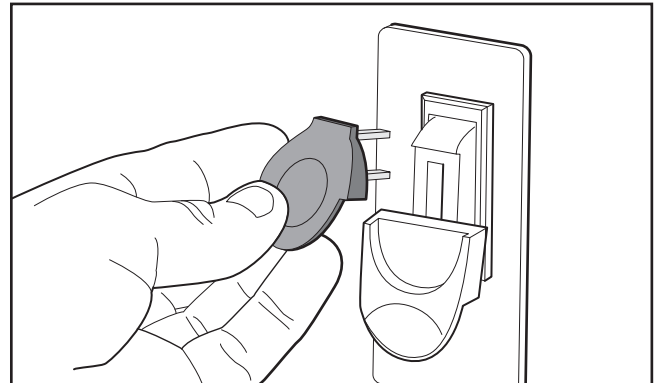
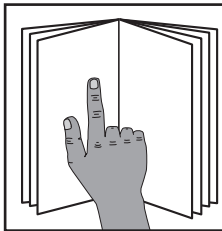

Figure 26. Removing switch key from paddle switch.

5. Try to start machine with paddle switch. The machine should not start.
 - If the machine *does not* start, the switch disabling feature is working as designed.
 - If the machine *does start*, immediately stop the machine. The switch disabling feature is not working correctly. This safety feature must work properly before proceeding with regular operations. Call Tech Support for help.



SECTION 4: OPERATIONS



!WARNING

To reduce your risk of serious injury, read this entire manual **BEFORE** using machine.

!WARNING

To reduce risk of eye injury from flying chips or lung damage from breathing dust, always wear safety glasses and a respirator when operating this machine.

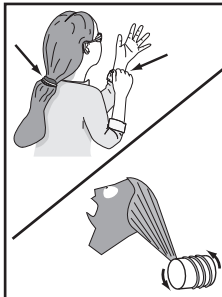
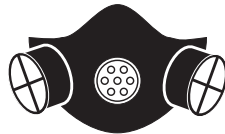

!WARNING

Keep hair, clothing, and jewelry away from moving parts at all times. Entanglement can result in death, amputation, or severe crushing injuries!

NOTICE

If you are not experienced with this type of machine, **WE STRONGLY RECOMMEND** that you seek additional training outside of this manual. Read books/magazines or get formal training before beginning any projects. Regardless of the content in this section, Grizzly Industrial will not be held liable for accidents caused by lack of training.

Operation Overview

The purpose of this overview is to provide the novice machine operator with a basic understanding of how the machine is used during operation, so the machine controls/components discussed later in this manual are easier to understand.

Due to the generic nature of this overview, it is **not** intended to be an instructional guide. To learn more about specific operations, read this entire manual, seek additional training from experienced machine operators, and do additional research outside of this manual by reading "how-to" books, trade magazines, or websites.

To complete a typical operation, the operator does the following:

1. Examines workpiece to make sure it is suitable for drilling.
2. Puts on required safety glasses and face shield.
3. Firmly secures workpiece to table using a vise or T-slot clamps.
4. Installs correct cutting tool for operation.
5. Adjusts table to correct height, then locks it in place.
6. Selects appropriate spindle speed according to V-belt configuration chart located inside belt cover.
7. Connects machine to power, and turns machine **ON**.
8. Begins drilling.
9. When finished, turns machine **OFF** and disconnects it from power.



Choosing Speeds

Using the Drill Bit Speed Chart

The chart shown in **Figure 27** is intended as a guide only. Always follow the manufacturer's speed recommendations if provided with your drill bits, cutters, or hole saws. Exceeding the recommended speeds may be dangerous to the operator.

The speeds shown here are intended to get you started. The optimum speed will always depend on various factors, including tool diameter, drilling pressure, material hardness, material quality, and desired finish.

Often, when drilling materials other than wood, some type of lubrication is necessary.

Lubrication Suggestions

WoodNone
 PlasticsSoapy Water
 BrassWater-Based Lubricant
 Aluminum..... Paraffin-Based Lubricant
 Mild Steel..... Oil-Based Lubricant

⚠ CAUTION

Larger bits turning at slower speeds tend to grab the workpiece aggressively. This can result in the operator's hand being pulled into the bit or the workpiece being thrown with great force. Always clamp the workpiece to the table to prevent injuries.

Twist/Brad Point Drill Bits	Soft Wood	Hard Wood	Plastic	Brass	Aluminum	Mild Steel
1/16" – 3/16"	3000	2500	2500	2500	3000	2500
13/64" – 3/8"	2000	1500	2000	1250	2500	1250
25/64" – 5/8"	1500	750	1500	750	1500	600
11/16" – 1"	750	500	1000	400	1000	350

Spade/Forstner Bits	Soft Wood	Hard Wood	Plastic	Brass	Aluminum	Mild Steel
1/4" – 1/2"	2000	1500	/	/	/	/
9/16" – 1"	1500	1250	/	/	/	/
1-1/8" – 1-7/8"	1000	750	/	/	/	/
2–3"	500	350	/	/	/	/

Hole Saws	Soft Wood	Hard Wood	Plastic	Brass	Aluminum	Mild Steel
1/2" – 7/8"	500	500	600	600	600	500
1" – 1-7/8"	400	400	500	500	500	400
2" – 2-7/8"	300	300	400	400	400	300
3" – 3-7/8"	200	200	300	300	300	200
4" – 5"	100	100	200	200	200	100

Rosette Cutters	Soft Wood	Hard Wood	Plastic	Brass	Aluminum	Mild Steel
Carbide Insert Type	350	250	/	/	/	/
One-Piece Type	1800	500	/	/	/	/

Tenon/Plug Cutters	Soft Wood	Hard Wood	Plastic	Brass	Aluminum	Mild Steel
3/8" – 1/2"	1200	1000	/	/	/	/
5/8" – 1"	800	600	/	/	/	/

Figure 27. Drill bit speed chart.



Changing Speeds

The Model G7943/G7944 are capable of 12 different spindle speed RPMs. Spindle speed is controlled by the configuration of V-belts and pulleys located inside the belt cover on top of the machine.

To change speeds:

1. DISCONNECT MACHINE FROM POWER!
2. Loosen the belt tension lock knobs (shown in **Figure 28**) on both sides of the headstock, so the motor is free to move.



Figure 28. Loosening lock knob (both sides).

3. Rotate the belt tension lever clockwise, as shown in **Figure 29**, to take tension off the V-belts.



Figure 29. Using the belt tension lever.

4. Locate the desired speed on the speed chart under the belt cover and move the V-belts to the desired V-grooves on the motor, idler, and spindle pulleys.

For Example: As indicated in the speed chart for **540 RPM (Figure 30)**, a belt combination of **A-1, 2-2** creates 540 RPM.

- The “A-1” refers to the belt position between the spindle pulley and the idler pulley.
- The “2-2” refers to the belt position between the motor pulley and the idler pulley.

Note: Both belts may have to be removed before certain speed changes can be made.

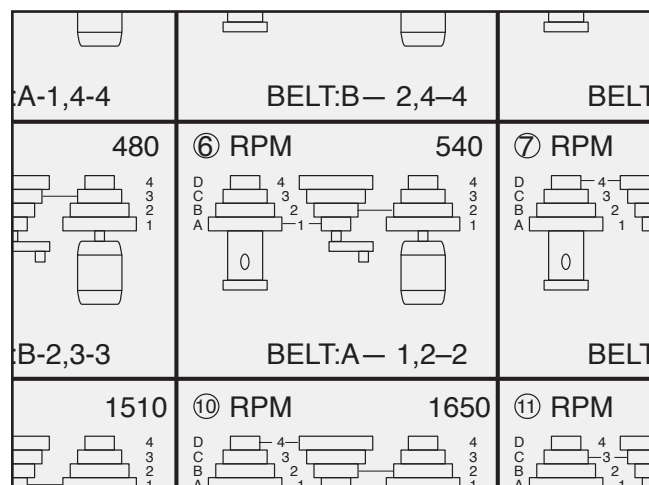

Figure 30. Pulley combination for 540 RPM for example.

5. Rotate the belt tension lever until the belts are tight. Tighten both lock knobs.
6. Close the cover before connecting the machine to power.



Drilling

The Model G7943/G7944 is designed for drilling holes in wood or metal. The basic operation of a drill press is lining up your drill bit with the intended hole location, turning the drill press **ON**, and using the downfeed levers to move the spinning drill bit into the workpiece.

For safe operation and optimum results, it is very important to follow these guidelines when drilling:

CLEARING CHIPS: Raise the drill bit often to clear chips and cool the drill bit. This will ease the work of the drill press motor and extend the life of your drill bits.

SECURING WORKPIECE TO TABLE: Secure the workpiece to the table or in a vise that is secured to the table before drilling.

PROTECTING TABLE: Protect the table by placing the workpiece on scrap wood, or center the location of the hole to be drilled over the pocket in the table when through drilling. Also, make use of the depth stop so that the drill bit goes no deeper than necessary.

USING CORRECT SPEEDS: Use the correct speed for the diameter of the drill bit being used and the type of material being drilled. Refer to the **Drill Bit Speed Chart** on **Page 27** to help you choose the correct speed for your application.

LARGE DIAMETER BITS: Large diameter drill bits require slower spindle speeds.

SMALL DIAMETER BITS: Smaller diameter drill bits require faster spindle speeds.

HARD MATERIAL: Harder materials (steel vs. wood) require slower drilling speeds.

SOFT MATERIAL: Soft materials require a faster drilling speed. (**NOTE:** Plastics can melt at too high of a spindle speed!)

LUBRICANT: Use some form of lubricant on all materials except wood. Refer to **Lubrication Suggestions** on **Page 27** to find the correct lubrication for your application.

DRILLING ACCURACY: To prevent drill bit wandering and ensure accurate placement of holes, mark the hole location with a center punch before drilling. Also consider using a center-point drill to start the hole.

PLUG/ROSETTE CUTTERS: Plug cutters and rosette cutters are for wood only. However, carbide-tipped bits and cutters cut at a higher speed and can cut materials other than wood, depending on the cutter type.

5-FLUTE/2-FLUTE CUTTERS: Use a 5-flute cutter when cutting into plastics, brass, aluminum, and mild steel. A 2-flute cutter can aggressively grab the workpiece and damage the tool if used with materials other than wood.

SPADE BITS AND PLASTIC: When drilling plastic with a spade bit, use a spade bit with spurs.

HOLE SAWS: When using hole saws, apply firm and even pressure, so the saw teeth contact the surface all at the same time—not at an angle. You can also flip the workpiece and finish drilling from the other side.

CAUTION

Larger bits turning at slower speeds tend to grab the workpiece aggressively. This can result in the operator's hand being pulled into the bit or the workpiece being thrown with great force. Always clamp the workpiece to the table to prevent injuries.



Installing/Removing Drill Bits

Any drill bit you install in the chuck must be tight enough that it will not come loose during operation.

Installing a Drill Bit

1. DISCONNECT MACHINE FROM POWER!
2. Open the drill chuck wide enough to accept the shank of the drill bit.
3. Insert the drill bit as far as possible into the chuck WITHOUT allowing the chuck jaws to touch the fluted portion of the bit, and hand tighten the chuck.

Note: Make sure small bits are not trapped between the edges of two jaws; if they are, reinstall the drill bit or it will not be secure enough to use for drilling.

4. Final tighten the drill bit with the chuck key.

Removing a Drill Bit

1. DISCONNECT MACHINE FROM POWER!
2. Use the chuck key to open the drill chuck, and catch the drill bit with a rag to protect your hands.

Depth Stop

The Model G7943/G7944 has a depth stop that allows you to drill repeated non-through holes to the same depth every time.

The depth stop consists of a stud attached to the quill with two hex nuts that can be lowered or raised on the stud so the lower nut (depth nut) hits a stop bracket when the drill bit is lowered. The upper hex nut (jam nut) is then used to tighten against the depth nut to secure it in place so it doesn't move with repeated operations. **Figure 31** shows the various components of the depth stop.

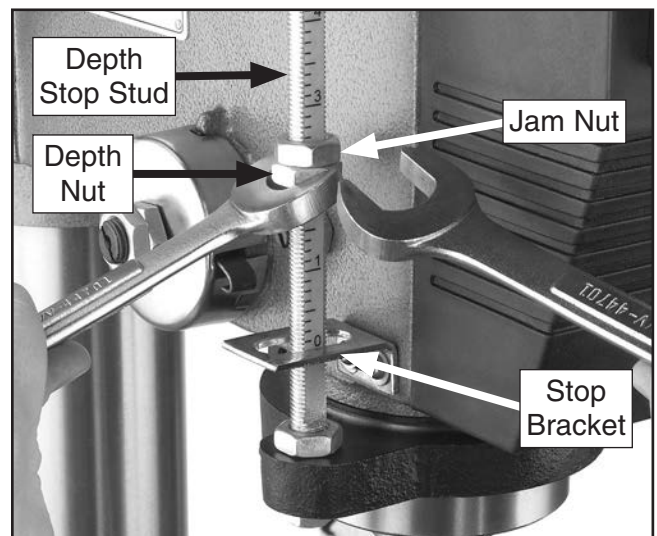

Figure 31. Depth stop components.

To set the depth stop:

1. Lower the drill bit to the required height.
2. Thread the depth nut down against the stop bracket.
3. Lower the jam nut against the depth nut.
4. Using wrenches, hold the depth nut in place and tighten the jam nut against the depth nut.

Note: The scale on the depth stop can be recalibrated if it gets moved or has changed since the factory setting. Refer to **Calibrating Depth Stop** on **Page 38** for instructions on how this is done.



Positioning Table

The table can be raised/lowered, rotated, and tilted 90° left or right. Table adjustment controls are shown in **Figure 32**.

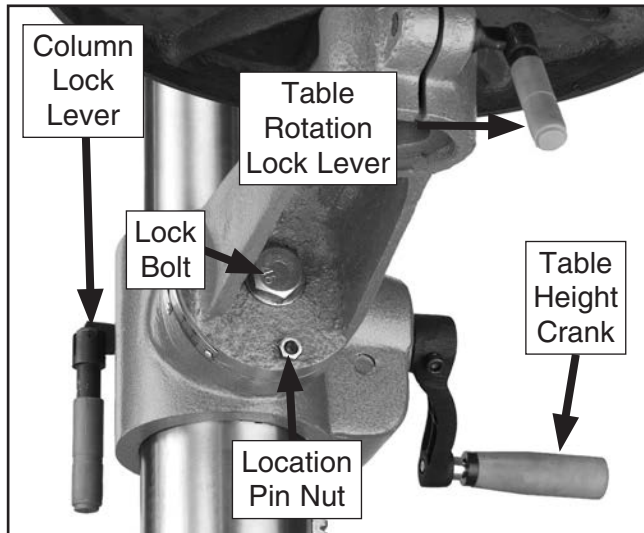

Figure 32. Table adjustment controls.

Table Height

1. Loosen the column lock lever.
2. Adjust the height.
3. Tighten the column lock lever.

Table Rotation

1. Loosen the table rotation lock lever.
2. Rotate the table as necessary.
3. Tighten the table rotation lock lever.

Table Tilt

1. Tighten the location pin nut to draw the location pin out of the hole.

Note: *The location pin is friction fit in the hole to lock the table at 0°. When reinstalling, set the table to 0°, back the nut off, and tap the pin back in the hole.*

2. Loosen the lock bolt and tilt the table to the desired angle (make sure the small lock lever is locked, so the table won't fall out).
3. Tighten the lock bolt.



Removing Arbor

The arbor can be removed to install other Morse Taper tooling in the spindle. A drift key is included to help remove the arbor or other tooling from the spindle. Usually, once the chuck and arbor have been properly mounted together, they are considered semi-permanent connections. (If you would like to install a different chuck, we recommend getting a new arbor for that chuck.)

To remove the drill chuck and arbor:

1. DISCONNECT MACHINE FROM POWER!
2. Rotate the spindle handles until the drift-key slot is exposed in the side of the quill.
3. Loosen the lock knob and rotate the hub clockwise (see **Figure 33**) until it stops.



Figure 33. Rotating hub.

4. Tighten the lock knob. The quill should not return up into the head casting when the depth stop is adjusted this way.
5. Move the table up until it is 1/4" below the bottom of the chuck, and place a towel or cloth under the chuck.

6. Rotate the spindle until the inner drift-key slot is aligned with the outer slot, as shown in **Figure 34**. You will see through the spindle when the slot is properly aligned.

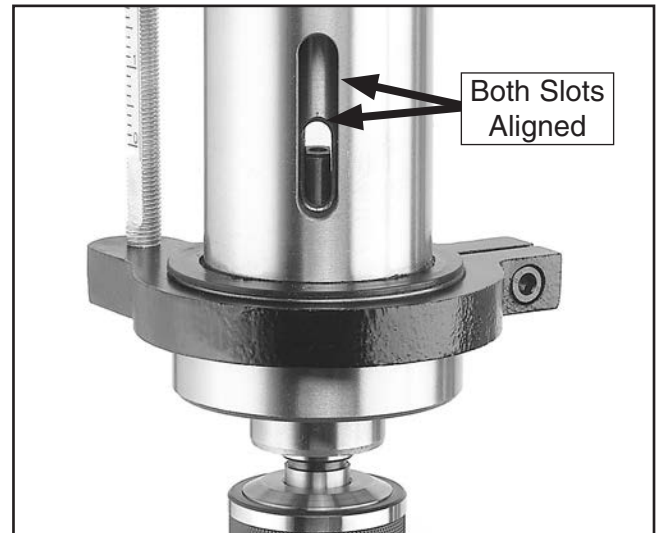

Figure 34. Inner and outer drift-key slots aligned.

7. Insert the drift key into the drift-key slot, and allow the quill to rise, trapping the drift key.
8. Tap the drift key with a rubber or wooden mallet, as shown in **Figure 35**, until the chuck releases.

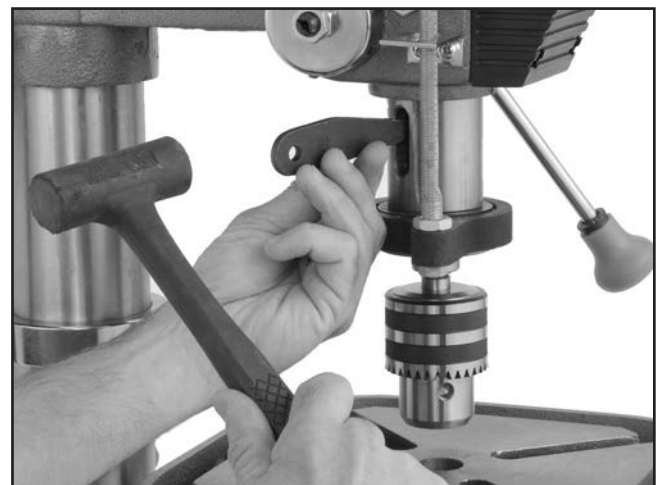

Figure 35. Using drift key to remove arbor.

9. Hold a downfeed handle with one hand, and loosen the depth stop lock with the other hand.
10. Carefully retract the quill into the headstock.



SECTION 5: ACCESSORIES

! WARNING

Installing unapproved accessories may cause machine to malfunction, resulting in serious personal injury or machine damage. To reduce this risk, only install accessories recommended for this machine by Grizzly.

NOTICE

Refer to our website or latest catalog for additional recommended accessories.

G2500—20-Pc. Regular Sanding Drum Set

Use on your drill press, lathe, or hand drill. This kit consists of 5 drums in popular 1/2" x 1/2", 3/4" x 1", 1" x 1", 1 1/2" x 1 1/2", and 2" x 1 1/2" sizes. Comes with 50, 80 and 120 grit sizes for each drum.



Figure 36. Model G2500 20-Pc. Sanding Drum Set.

G5753—Drill Press Vise 6"

If you use a drill press and value your fingers, you need one of these. Made from high-grade cast iron, these hefty horizontal vises offer support and stability, allowing you to keep your hands well away from fast moving bits and cutters.

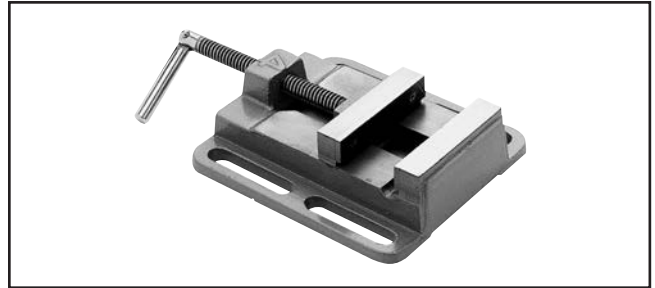

Figure 37. Model G5753 Drill Press Vise 6".

G5562—SLIPIT® 1 Qt. Gel

G5563—SLIPIT® 12 Oz. Spray

G2871—Boeshield® T-9 12 Oz. Spray

G2870—Boeshield® T-9 4 Oz. Spray

H3788—G96® Gun Treatment 12 Oz. Spray

H3789—G96® Gun Treatment 4.5 Oz. Spray



Figure 38. Recommended products for protecting unpainted cast-iron/steel areas.

order online at www.grizzly.com or call 1-800-523-4777



Basic Eye Protection

T20501—Face Shield Crown Protector 4"

T20502—Face Shield Crown Protector 7"

T20503—Face Shield Window

T20451—"Kirova" Clear Safety Glasses

T20452—"Kirova" Anti-Reflective S. Glasses

T20456—DAKURA Safety Glasses, Black/Clear



Figure 39. Assortment of basic eye protection.

H8203—Professional Drill Bit Sharpening Machine (For Bits 1/8"–1/2" in Diameter)

This precision made Drill Bit Sharpening Machine is so simple to use, anyone can sharpen dull, smaller bits in three easy steps. Just set the drill bit in the collet, grind the taper relief angle, then grind the web thinning angle to reduce the center point width. It features a depth adjustment gauge, tapered diamond wheel, 90°–140° angle setting adjustment, and built-in collet tray. Collet sizes include 1/8", 5/32", 3/16", 1/4", 9/32", 5/16", 3/8", 25/64", 7/16", 15/32", and 1/2". Patented in the US!



Figure 40. H8203 Professional Drill Bit Sharpening Machine.

D2139—Steelex® Cobalt Alloy Drill Bits 21-Pc. Set

Because of its resistance to heat and stress, Cobalt Alloy bits turn faster without overheating. The 135° split point enables the drill to use less thrust and eliminates the tendency of the drill point to walk, which makes these great for use in portable drills or drill presses. Cobalt Alloy bits will retain their edge sharpness longer than normal HSS bits, resulting in a significant saving of time and money in the workshop. Includes 1/16"- 3/8" bits and a heavy-gauge steel index case for storage.



Figure 41. Model D2139 21-Pc. Alloy Drill Bits.

G8581—1/2" Keyless Drill Chuck JT#33

Industrial-grade keyless chucks are excellent for quick bit changes. Knurled grips and exceptional accuracy make these chucks an indispensable part of any shop. 0 – 1/2" capacity with a Jacobs Taper #33 in back.

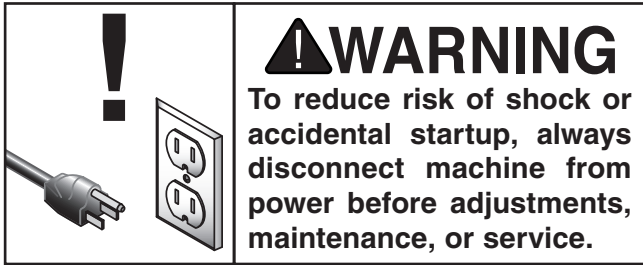

Figure 42. Model G8581 1/2" Keyless Drill Chuck JT#33.

order online at www.grizzly.com or call 1-800-523-4777



SECTION 6: MAINTENANCE



General

For optimum performance from this machine, this maintenance schedule must be strictly followed.

Ongoing

To maintain a low risk of injury and proper machine operation, if you ever observe any of the items below, shut down the machine immediately and fix the problem before continuing operations:

- Loose mounting bolts.
- Worn switch.
- Worn or damaged wires.
- Damaged V-belts.
- Any other unsafe condition.

Monthly Check

- V-belt tension, damage, or wear.
- Clean/vacuum dust buildup off motor.

Cleaning & Protecting

Cleaning the Model G7943/G7944 is relatively easy. Vacuum excess wood chips and sawdust, and wipe off the remaining dust with a dry cloth. If any resin has built up, use a resin-dissolving cleaner to remove it.

Protect the unpainted cast-iron table by wiping it clean after every use—this ensures moisture from wood dust does not remain on bare metal surfaces. Keep the table rust-free with regular applications of products like G96® Gun Treatment, SLIPIT®, or Boeshield® T-9 (see **Page 33** for more details).

Lubrication

Since all bearings are shielded and permanently lubricated, simply leave them alone until they need to be replaced. DO NOT lubricate them.

Keep quill, spindle, column, and table top well lubricated to prevent rust.

V-Belts

Inspect regularly for tension and wear. Check pulleys to ensure that they are properly aligned. See **Changing Speeds** on **Page 28** for more information about removing/installing belts if you need help replacing the belts.



SECTION 7: SERVICE

Review the troubleshooting and procedures in this section to fix or adjust your machine if a problem develops. If you need replacement parts or you are unsure of your repair skills, then feel free to call our Technical Support at (570) 546-9663.

Troubleshooting



Motor & Electrical

Symptom	Possible Cause	Possible Solution
Machine does not start or a breaker trips.	<ol style="list-style-type: none"> 1. Switch disabling key removed or at fault. 2. Incorrect power supply voltage or circuit size. 3. Power supply circuit breaker tripped or fuse blown. 4. Motor wires connected incorrectly. 5. Wiring open/has high resistance. 6. Start capacitor at fault. 7. Centrifugal switch at fault. 8. Motor at fault. 	<ol style="list-style-type: none"> 1. Insert disabling key or replace. 2. Ensure correct power supply voltage and circuit size. 3. Ensure circuit is sized correctly and free of shorts. Reset circuit breaker or replace fuse. 4. Correct motor wiring connections (Page 40). 5. Check/fix broken, disconnected, or corroded wires. 6. Test/replace. 7. Adjust/replace centrifugal switch if available. 8. Test/repair/replace.
Machine stalls or is underpowered.	<ol style="list-style-type: none"> 1. Incorrect/dull cutter/bit for task. 2. Feed rate/cutting speed too fast. 3. Belt(s) slipping. 4. Machine undersized for task. 5. Motor overheated. 6. Pulley slipping on shaft. 7. Centrifugal switch at fault. 8. Motor at fault. 	<ol style="list-style-type: none"> 1. Use correct cutter/bit. 2. Decrease feed rate/cutting speed (Page 28). 3. Ensure belts are oil free, tension/replace belt(s); ensure pulleys are aligned. 4. Perform operation with different machine. 5. Clean motor, let cool, and reduce workload. 6. Tighten loose pulley; replace broken/missing parts. 7. Adjust/replace centrifugal switch if available. 8. Test/repair/replace.
Machine has vibration or noisy operation.	<ol style="list-style-type: none"> 1. Motor or other drive component loose. 2. V-belt(s) worn or loose. 3. Motor fan rubbing on fan cover. 4. Pulley loose. 5. Motor mount loose/broken. 6. Motor or spindle bearings at fault. 7. Chuck unbalanced or cutter dull. 	<ol style="list-style-type: none"> 1. Inspect/replace damaged bolts/nuts, and retighten with thread locking fluid, if necessary. 2. Inspect/replace belts with a new matched set (Page 28). 3. Fix/replace fan cover; replace loose/damaged fan. 4. Re-align/replace shaft, pulley set screw, and key. 5. Tighten/replace. 6. Test by rotating shaft; rotational grinding/loose shaft requires bearing replacement. 7. Replace chuck; replace/resharpen cutter.



Drill Press Operations

Symptom	Possible Cause	Possible Solution
Tool loose/lack of power in spindle.	<ol style="list-style-type: none"> 1. Tool incorrectly installed in spindle taper. 2. Debris on tool or spindle taper mating surfaces. 3. Taking too big of a cut. 4. V-belts are loose. 5. Wrong voltage. 	<ol style="list-style-type: none"> 1. Remove and re-install (Page 32). 2. Clean tool and spindle taper. 3. Lessen depth of cut and allow chips to clear (Page 29). 4. Properly tension V-belts (Page 28). 5. Correct voltage.
Workpiece or tool vibrates or chatters during operation.	<ol style="list-style-type: none"> 1. Table locks not tight. 2. Workpiece not secure. 3. Spindle speed/feed rate is too fast. 4. Spindle or quill extended too far down. 	<ol style="list-style-type: none"> 1. Tighten table locks (Page 31). 2. Properly clamp workpiece on table or in vise. 3. Set spindle speed correctly (Page 28) or use slower feed rate. 4. Fully retract spindle and lower headstock. This increases rigidity to decrease vibration.
Headstock is hard to raise.	<ol style="list-style-type: none"> 1. Headstock lock nuts at fault. 2. Rack and pinion at fault or jammed with grime/debris. 	<ol style="list-style-type: none"> 1. Loosen/replace lock nuts. 2. Fix/replace broken or loose parts; clean and lubricate rack and pinion.
Bad surface finish.	<ol style="list-style-type: none"> 1. Spindle speed too fast for workpiece material. 2. Dull or incorrect cutting tool. 3. Wrong rotation direction of cutting tool. 4. Workpiece not secure. 5. Spindle extended too far down during operation. 	<ol style="list-style-type: none"> 1. Set spindle speed correctly (Page 28). 2. Sharpen cutting tool or select one that better suits the operation. 3. Check for proper cutting tool rotation. 4. Properly clamp workpiece on table or in vise. 5. Fully retract spindle and lower headstock. This increases rigidity.
Spindle overheats.	<ol style="list-style-type: none"> 1. Drill operated at high speeds for extended period. 	<ol style="list-style-type: none"> 1. Allow drill to cool.
Spindle does not return to highest position.	<ol style="list-style-type: none"> 1. Poorly adjusted return spring. 2. Worn return spring. 	<ol style="list-style-type: none"> 1. Increase return spring tension (Page 38). 2. Replace return spring.
Depth stop producing inaccurate results.	<ol style="list-style-type: none"> 1. Depth stop not calibrated. 	<ol style="list-style-type: none"> 1. Calibrate depth stop (Page 38).



Calibrating Depth Stop

The drill press comes fitted with a depth stop to use when drilling multiple holes at the same depth. The scale on this depth stop can be calibrated if it ever becomes incorrect.

To calibrate the depth stop:

1. Loosen the jam nut and calibration nut shown in **Figure 43**.

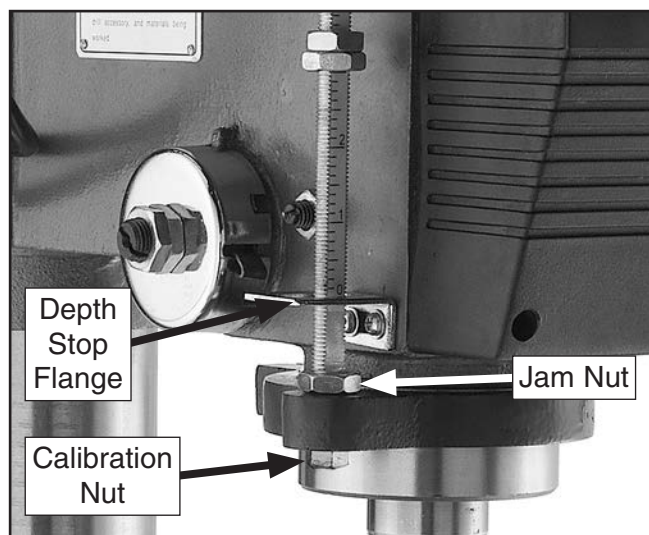

Figure 43. Depth stop assembly.

2. Use the calibration nut to zero the depth stop scale with the depth stop flange.
3. Hold the depth stop at zero, and tighten the jam nut to hold the depth stop in position.
4. Test the depth stop by measuring how far the spindle actually moves with respect to where you set the depth stop.

Tensioning Spindle Return Spring

The tension of the spindle return spring makes the spindle automatically return to the top (starting) position when the downfeed handle is released. This spring is pre-adjusted at the factory, and typically will never need further adjustment during the life of the drill press. However, additional tension can be applied if the spindle stops automatically returning to the top position.



! WARNING
Wear safety glasses when adjusting springs. Serious injury may occur if this warning is ignored!

Items Needed	Qty
Heavy Leather Gloves	1 Pr
Shop Rags	As Needed
Open-End Wrench 24mm	1

To adjust spindle return spring tension:

1. DISCONNECT MACHINE FROM POWER!
2. Wipe off any oil on the spring lock cover so it does not slip in your fingers when you hold the cover from spinning (see **Figure 44**).

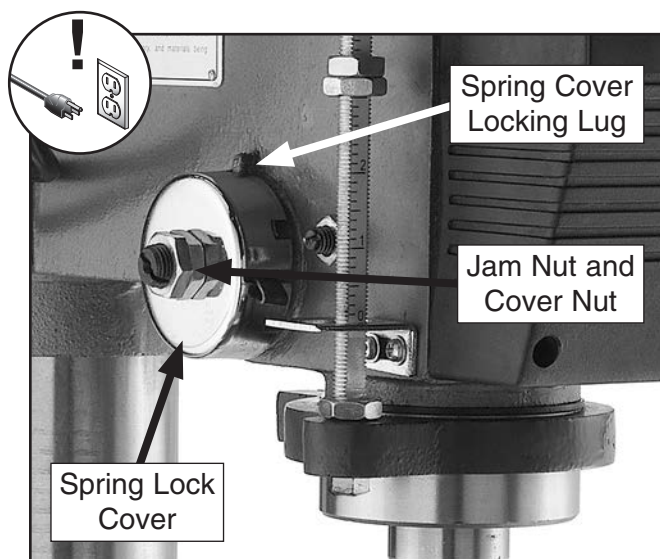

Figure 44. Spindle return spring assembly.



3. While holding the spring lock cover against the side of the headstock so the cover stays splined with the locking lug, as shown in **Figure 45**, loosen the jam nut and loosen the cover nut approximately $\frac{1}{4}$ " each.

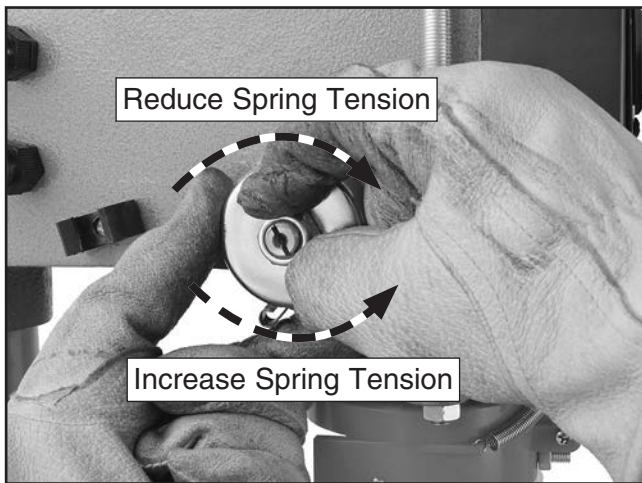

Figure 45. Loosening cover and jam nut.

⚠ CAUTION

A high-tension coiled spring is underneath the cover. Put on heavy leather gloves to protect yours hands from possible lacerations when removing the cover.

4. Put on heavy leather gloves to protect your hands from possible lacerations if the spring uncoils during the next step.
5. Pull the cover outward just enough to disengage the spring-cover lock slot from the locking lug.

CAUTION: *It is important to keep a good grip during this step. Letting go of the cover will cause the spring to rapidly uncoil.*

6. Rotate the cover counterclockwise to increase spring tension, or let the cover slowly unwind in the clockwise direction to reduce spring tension (see **Figure 45**).
7. Engage the next available spring-cover lock slot with the locking lug and hold the spring lock cover tightly against the side of the headstock.
8. Snug the cover nut against the spring cover just until the nut stops, and then back off the nut approximately $\frac{1}{3}$ turn, or just enough so there is no binding at complete spindle travel.
9. Hold the cover nut and tighten the jam nut against the cover nut.



SECTION 8: WIRING

These pages are current at the time of printing. However, in the spirit of improvement, we may make changes to the electrical systems of future machines. Compare the manufacture date of your machine to the one stated in this manual, and study this section carefully.

If there are differences between your machine and what is shown in this section, call Technical Support at (570) 546-9663 for assistance BEFORE making any changes to the wiring on your machine. An updated wiring diagram may be available. **Note:** *Please gather the serial number and manufacture date of your machine before calling. This information can be found on the main machine label.*

WARNING

Wiring Safety Instructions

SHOCK HAZARD. Working on wiring that is connected to a power source is extremely dangerous. Touching electrified parts will result in personal injury including but not limited to severe burns, electrocution, or death. Disconnect the power from the machine before servicing electrical components!

MODIFICATIONS. Modifying the wiring beyond what is shown in the diagram may lead to unpredictable results, including serious injury or fire. This includes the installation of unapproved after-market parts.

WIRE CONNECTIONS. All connections must be tight to prevent wires from loosening during machine operation. Double-check all wires disconnected or connected during any wiring task to ensure tight connections.

CIRCUIT REQUIREMENTS. You MUST follow the requirements at the beginning of this manual when connecting your machine to a power source.

WIRE/COMPONENT DAMAGE. Damaged wires or components increase the risk of serious personal injury, fire, or machine damage. If you notice that any wires or components are damaged while performing a wiring task, replace those wires or components.

MOTOR WIRING. The motor wiring shown in these diagrams is current at the time of printing but may not match your machine. If you find this to be the case, use the wiring diagram inside the motor junction box.















CAPACITORS/INVERTERS. Some capacitors and power inverters store an electrical charge for up to 10 minutes after being disconnected from the power source. To reduce the risk of being shocked, wait at least this long before working on capacitors.

EXPERIENCING DIFFICULTIES. If you are experiencing difficulties understanding the information included in this section, contact our Technical Support at (570) 546-9663.

NOTICE

The photos and diagrams included in this section are best viewed in color. You can view these pages in color at www.grizzly.com.

COLOR KEY

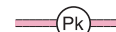
BLACK		BLUE		YELLOW		LIGHT BLUE	
WHITE		BROWN		YELLOW GREEN		BLUE WHITE	
GREEN		GRAY		PURPLE		TURQUOISE	
RED		ORANGE		PINK			



Electrical Components

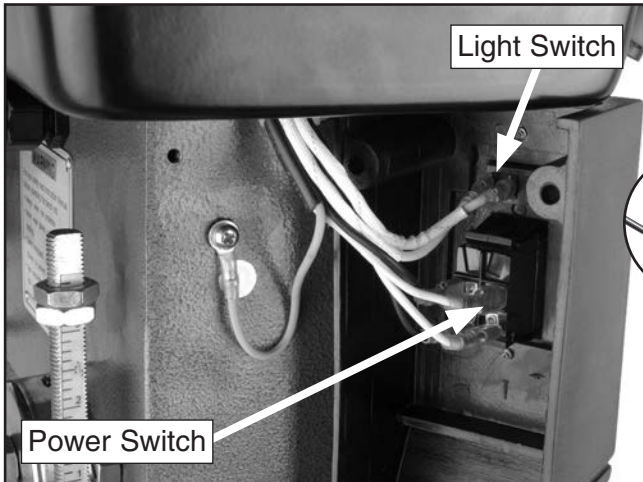

Figure 46. Power and light switch assembly.

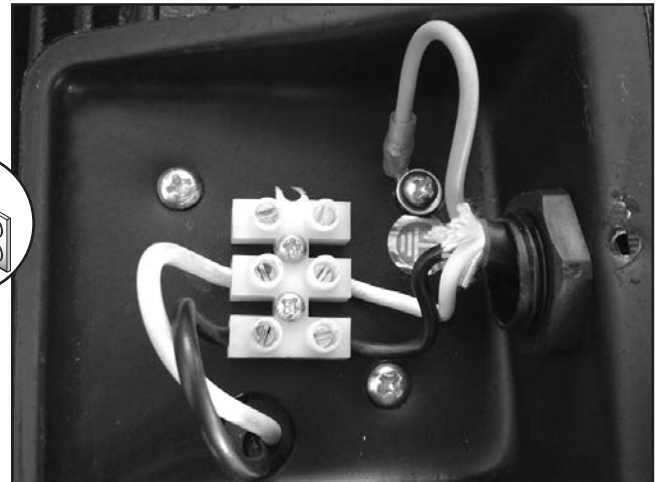

Figure 48. Motor wiring inside junction box.

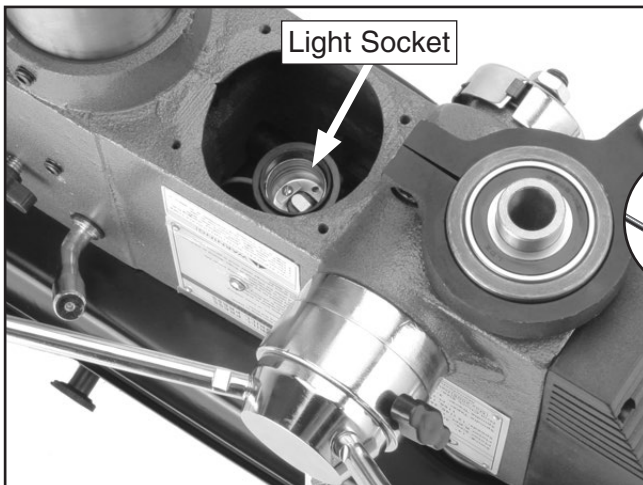

Figure 47. Light socket with dust plug removed.

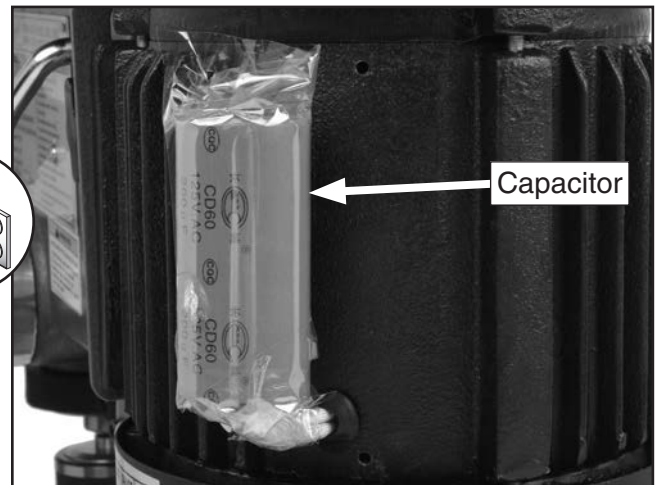
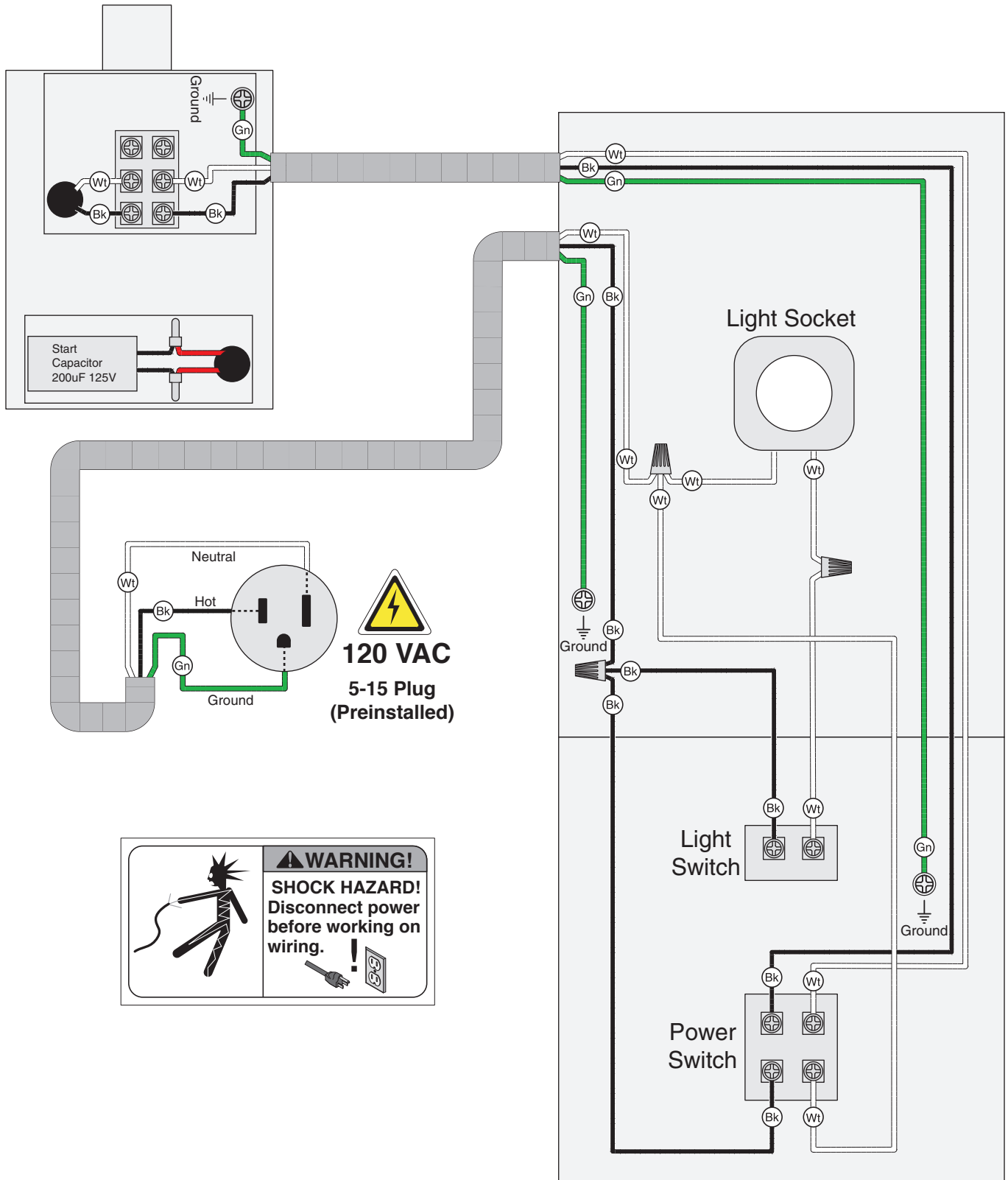

Figure 49. Start capacitor.

G7943/G7944 Wiring Diagram



⚠ WARNING!
SHOCK HAZARD!
 Disconnect power before working on wiring.

120 VAC
5-15 Plug
(Preinstalled)



SECTION 9: PARTS

G7943/G7944 Breakdown

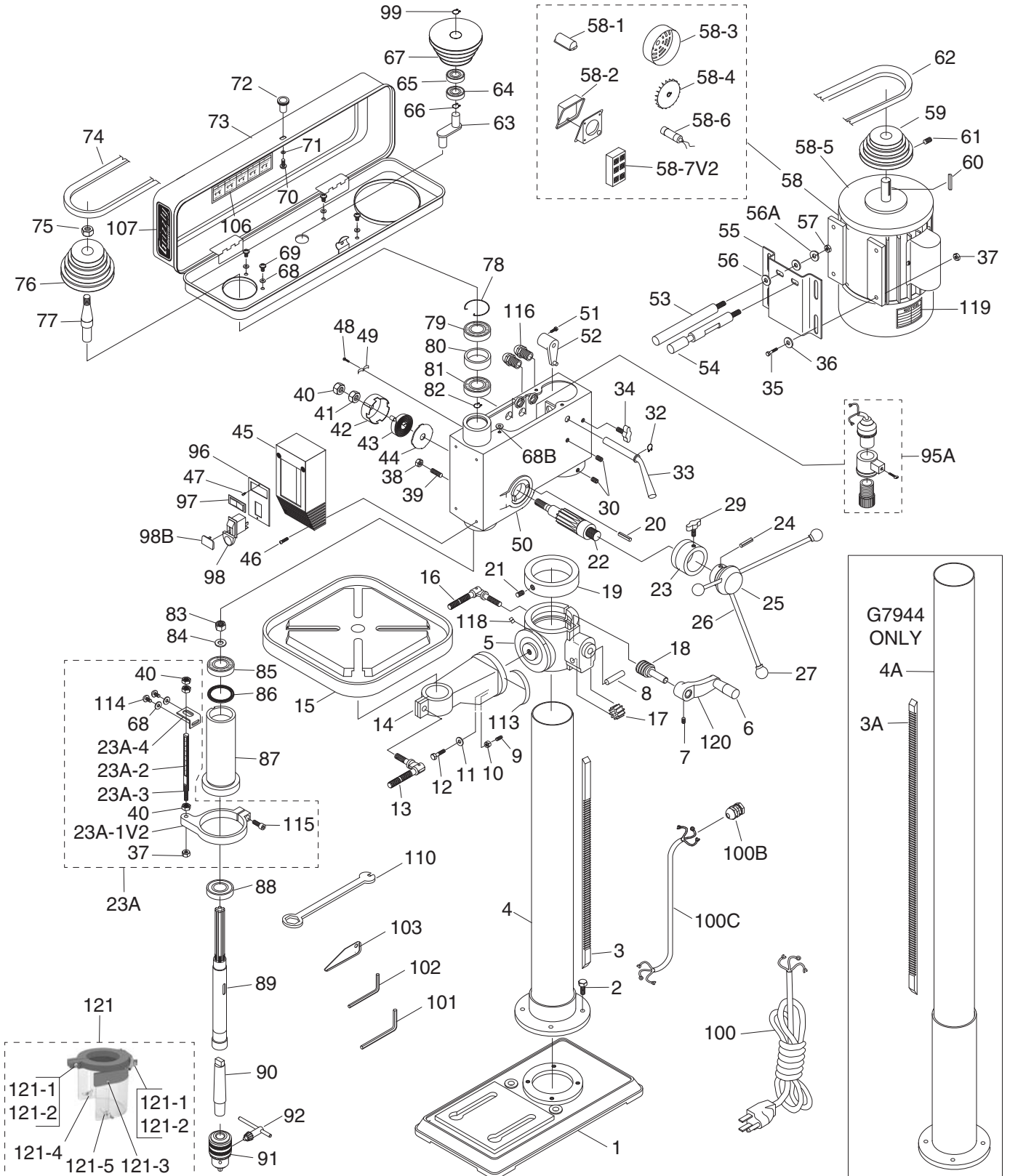

G7943/G7944 Parts List

REF	PART #	DESCRIPTION
1	P7943001	BASE V2.07.04
2	P7943002	HEX BOLT M10-1.5 x 25
3	P7943003	RACK (G7943)
3A	P7944003A	RACK (G7944)
4	P7943004	COLUMN W/COL SHLDR (G7943)
4A	P7944004A	COLUMN W/COL SHLDR (G7944)
5	P7943005	TABLE BRACKET
6	P7943006	HANDLE
7	P7943007	SET SCREW M6-1 X 10
8	P7943008	SHAFT
9	P7943009	TABLE PIN
10	P7943010	HEX NUT M6-1
11	P7943011	FLAT WASHER 16MM
12	P7943012	HEX BOLT M16-2 X 40
13	P7943013	TABLE BOLT M10-1.5 X 30
14	P7943014	TABLE ARM BRACKET
15	P7943015	TABLE
16	P7943016	CLAMP BOLT M12-1.75
17	P7943017	GEAR
18	P7943018	WORM GEAR
19	P7943019	RACK RING
20	P7943020	PIN-STOP
21	P7943021	SET SCREW M6-1 x 10
22	P7943022	FEED SHAFT
23	P7943023	DOWNFEED LOCK RING
23A	P7943023A	DEPTH RING ASSY
23A-1V2	P7943023A-1V2	DEPTH STOP BRACKET V2.12.12
23A-2	P7943023A-2	SCALE V2.11.02
23A-3	P7943023A-3	THREADED DEPTH BAR
23A-4	P7943023A-4	RIGHT-ANGLE BRACKET
24	P7943024	ROLL PIN 5 X 40
25	P7943025	HANDLE BODY
26	P7943026	HANDLE
27	P7943027	KNOB
29	P7943029	SLIDE BAR BOLT M8-1.25 X 20
30	P7943030	SET SCREW M10-1.5 X 12
32	P7943032	EXT RETAINING RING 16MM
33	P7943033	SHIFTER BAR
34	P7943034	SLIDE BAR BOLT M10-1.5 X 25
35	P7943035	HEX BOLT M8-1.25 X 30
36	P7943036	FLAT WASHER 8MM
37	P7943037	HEX NUT M8-1.25
38	P7943038	HEX NUT M10-1.25
39	P7943039	SET SCREW M10-1.5 x 30
40	P7943040	HEX NUT M12-1.5 THIN
41	P7943041	HEX NUT M12-1.5 THIN
42	P7943042	SPRING CAP
43	P7943043	SPRING-TORSION
44	P7943044	SPRING COVER
45	P7943045	SWITCH BOX
46	P7943046	PHLP HD SCR M5-.8 X 12
47	P7943047	TAP SCREW M4.2 X 9
48	P7943048	PHLP HD SCR M5-.8 X 10

REF	PART #	DESCRIPTION
49	P7943049	CORD CLAMP
50	P7943050	HEADSTOCK
51	P7943051	HEX BOLT M8-1.25 X 16
52	P7943052	SHIFTER
53	P7943053	SLIDE BAR
54	P7943054	SLIDE BAR
55	P7943055	MOTOR BASE
56	P7943056	FLAT WASHER 12MM
56A	P7943056A	LOCK WASHER 12MM
57	P7943057	HEX NUT M12-1.75
58	P7943058	MOTOR 3/4HP 120V 1PH
58-1	P7943058-1	CAPACITOR COVER
58-2	P7943058-2	JUNCTION BOX
58-3	P7943058-3	MOTOR COVER
58-4	P7943058-4	MOTOR FAN
58-5	P7943058-5	CAST-IRON END BELL (MOTOR)
58-6	P7943058-6	S CAPACITOR 200UF 125VAC
58-7V2	P7943058-7V2	TERMINAL BLOCK V2.05.18
59	P7943059	MOTOR PULLEY V2.02.99
60	P7943060	KEY 5 X 5 X 25
61	P7943061	SET SCREW M6-1 X 10
62	P7943062	V-BELT M24 3L240
63	P7943063	CENTER SHAFT
64	P7943064	BALL BEARING 6202ZZ
65	P7943065	BALL BEARING 6202ZZ
66	P7943066	EXT RETAINING RING 15MM
67	P7943067	CENTER PULLEY V2.02.99
68	P7943068	FLAT WASHER 6MM
68B	P7943068B	FLAT WASHER 6MM
69	P7943069	PHLP HD SCR M6-1 X 10
70	P7943070	PHLP HD SCR M5-.8 X 10
71	P7943071	FLAT WASHER 5MM
72	P7943072	KNOB
73	P7943073	PULLEY COVER
74	P7943074	V-BELT M25 3L250
75	P7943075	PULLEY NUT
76	P7943076	SPINDLE PULLEY V2.02.99
77	P7943077	INSERT PULLEY V2.02.99
78	P7943078	INT RETAINING RING 52MM
79	P7943079	BALL BEARING 6205ZZ
80	P7943080	SPACER
81	P7943081	BALL BEARING 6205ZZ
82	P7943082	INT RETAINING RING 25MM
83	P7943083	ROUND NUT M17-1
84	P7943084	TAB WASHER
85	P7943085	BALL BEARING P6203Z
86	P7943086	RUBBER WASHER 62 X 50 X 2
87	P7943087	SPINDLE SLEEVE
88	P7943088	BALL BEARING 6205ZZ
89	P7943089	SPINDLE
90	P7943090	ARBOR
91	P7943091	CHUCK
92	P7943092	CHUCK KEY



G7943/G7944 Parts List Cont.

REF	PART #	DESCRIPTION
95A	P7943095A	LIGHT SOCKET ASSEMBLY
96	P7943096	SWITCH BASE
97	P7943097	SWITCH (LIGHT)
98	P7943098	PADDLE SWITCH 120/240V W/KEY
98B	P7943098B	YELLOW SWITCH KEY
99	P7943099	INT RETAINING RING 35MM
100	P7943100	POWER CORD 18G 3W 72" 5-15P
100B	P7943100B	STRAIN RELIEF
100C	P7943100C	MOTOR CORD
101	P7943101	HEX WRENCH 5MM
102	P7943102	HEX WRENCH 3MM
103	P7943103	WEDGE SHIFTER
104	P7943104	LIGHT WARNING LABEL
106	P7943106	SPEED CHART LABEL
107	P7943107	GRIZZLY BLACK/AL LABEL

REF	PART #	DESCRIPTION
110	P7943110	TABLE BOLT WRENCH
113	P7943113	ANGLE SCALE
114	P7943114	PHLP HD SCR M6-1 X 10
115	P7943115	CAP SCREW M8-1.25 X 20
116	P7943116	STRAIN RELIEF
117	P7943117	DRILL PRESS LABEL
118	P7943118	INDICATOR
119	P7943119	MOTOR LABEL
120	P7943120	CRANK LEVER
121	P7943121	CHUCK GUARD ASSEMBLY
121-1	P7943121-1	PHLP HD SCR M4-.7 X 30
121-2	P7943121-2	HEX NUT M4-.7
121-3	P7943121-3	TAP SCREW M2.2 X 4.5
121-4	P7943121-4	HEX BOLT M5-.8 X 12
121-5	P7943121-5	WING NUT M5-.8

We do our best to stock replacement parts when possible, but we cannot guarantee that all parts shown are available for purchase. Call **(800) 523-4777** or visit **www.grizzly.com/parts** to check for availability.



G7943/G7944 Labels & Cosmetics

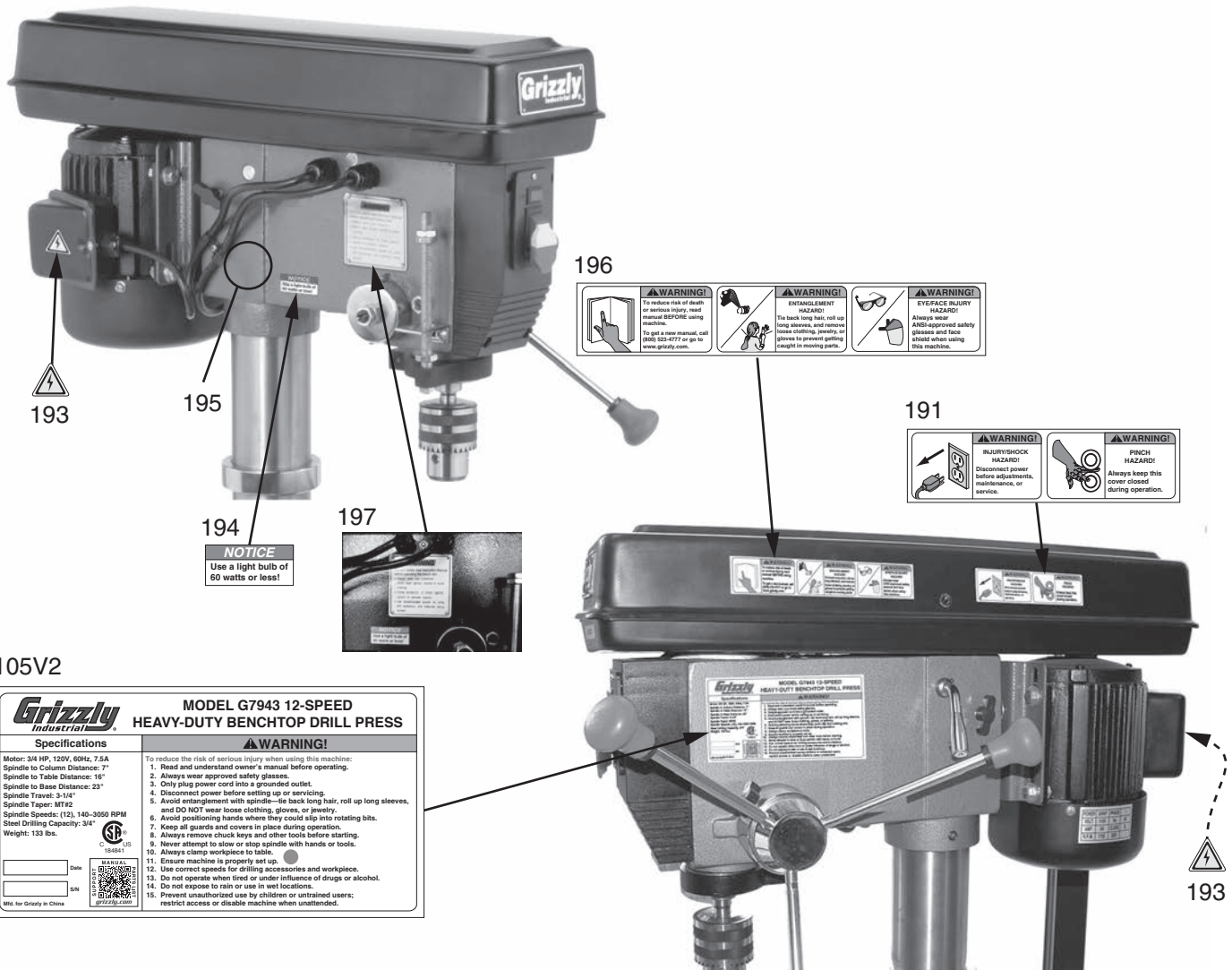

105V2

Grizzly Industrial		
MODEL G7943 12-SPEED HEAVY-DUTY BENCHTOP DRILL PRESS		
Specifications	WARNING!	
Motor: 3/4 HP, 120V, 60Hz, 7.5A	To reduce the risk of serious injury when using this machine: 1. Read and understand owner's manual before operating. 2. Always wear approved safety glasses. 3. Only plug power cord into a grounded outlet. 4. Disconnect power before setting up or servicing. 5. Avoid entanglement with spindle—tie back long hair, roll up long sleeves, and DO NOT wear loose clothing, gloves, or jewelry. 6. Avoid positioning hands where they could slip into rotating bits. 7. Keep all guards and covers in place during operation. 8. Always remove chuck keys and other tools before starting. 9. Never attempt to slow or stop spindle with hands or tools. 10. Always clamp workpiece to table. 11. Ensure machine is properly set up. 12. Use correct speeds for drilling accessories and workpiece. 13. Do not operate when tired or under influence of drugs or alcohol. 14. Do not expose to rain or use in wet locations. 15. Prevent unauthorized use by children or untrained users; restrict access or disable machine when unattended.	
Spindle to Column Distance: 7"		
Spindle to Table Distance: 16"		
Spindle to Base Distance: 23"		
Spindle Travel: 3-1/4"		
Spindle Taper: MT#2		
Spindle Speeds: (12), 140-3050 RPM		
Steel Drilling Capacity: 3/4"		
Weight: 123 lbs.		
DATE: _____		
S/N: _____		
		
<small>Mfd. for Grizzly in China</small>		

REF	PART #	DESCRIPTION
105V2	P7943105V2	WARNING ID/LABEL V2.09.17 (G7943)
105V2	P7944105V2	WARNING ID/LABEL V2.09.17 (G7944)
191	P7943191	SHOCK-PINCH LABEL
193	P7943193	ELECTRICITY WARNING LABEL

REF	PART #	DESCRIPTION
194	P7943194	60W LIGHT BULB NOTICE
195	P7943195	TOUCH-UP PAINT, GRIZZLY GREEN
196	P7943196	READ-ENTANGLE-EYE WARNING LABEL
197	P7943197	WARNING LABEL (FACTORY)

⚠ WARNING

Safety labels help reduce the risk of serious injury caused by machine hazards. If any label comes off or becomes unreadable, the owner of this machine **MUST** replace it in the original location before resuming operations. For replacements, contact (800) 523-4777 or www.grizzly.com.

BUY PARTS ONLINE AT GRIZZLY.COM!
Scan QR code to visit our Parts Store.





WARRANTY CARD

Name _____
 Street _____
 City _____ State _____ Zip _____
 Phone # _____ Email _____
 Model # _____ Order # _____ Serial # _____

The following information is given on a voluntary basis. It will be used for marketing purposes to help us develop better products and services. **Of course, all information is strictly confidential.**

1. How did you learn about us?

Advertisement Friend Catalog
 Card Deck Website Other:

2. Which of the following magazines do you subscribe to?

<input type="checkbox"/> Cabinetmaker & FDM	<input type="checkbox"/> Popular Science	<input type="checkbox"/> Wooden Boat
<input type="checkbox"/> Family Handyman	<input type="checkbox"/> Popular Woodworking	<input type="checkbox"/> Woodshop News
<input type="checkbox"/> Hand Loader	<input type="checkbox"/> Precision Shooter	<input type="checkbox"/> Woodsmith
<input type="checkbox"/> Handy	<input type="checkbox"/> Projects in Metal	<input type="checkbox"/> Woodwork
<input type="checkbox"/> Home Shop Machinist	<input type="checkbox"/> RC Modeler	<input type="checkbox"/> Woodworker West
<input type="checkbox"/> Journal of Light Cont.	<input type="checkbox"/> Rifle	<input type="checkbox"/> Woodworker's Journal
<input type="checkbox"/> Live Steam	<input type="checkbox"/> Shop Notes	<input type="checkbox"/> Other:
<input type="checkbox"/> Model Airplane News	<input type="checkbox"/> Shotgun News	
<input type="checkbox"/> Old House Journal	<input type="checkbox"/> Today's Homeowner	
<input type="checkbox"/> Popular Mechanics	<input type="checkbox"/> Wood	

3. What is your annual household income?

\$20,000-\$29,000 \$30,000-\$39,000 \$40,000-\$49,000
 \$50,000-\$59,000 \$60,000-\$69,000 \$70,000+

4. What is your age group?

20-29 30-39 40-49
 50-59 60-69 70+

5. How long have you been a woodworker/metalworker?

0-2 Years 2-8 Years 8-20 Years 20+ Years

6. How many of your machines or tools are Grizzly?

0-2 3-5 6-9 10+

7. Do you think your machine represents a good value? Yes No

8. Would you recommend Grizzly Industrial to a friend? Yes No

9. Would you allow us to use your name as a reference for Grizzly customers in your area?

Note: We never use names more than 3 times. Yes No

10. Comments: _____

CUT ALONG DOTTED LINE

FOLD ALONG DOTTED LINE



Place
Stamp
Here



GRIZZLY INDUSTRIAL, INC.
P.O. BOX 2069
BELLINGHAM, WA 98227-2069



FOLD ALONG DOTTED LINE

Send a Grizzly Catalog to a friend:

Name _____
Street _____
City _____ State _____ Zip _____

TAPE ALONG EDGES--PLEASE DO NOT STAPLE

WARRANTY AND RETURNS

Grizzly Industrial, Inc. warrants every product it sells for a period of **1 year** to the original purchaser from the date of purchase. This warranty does not apply to defects due directly or indirectly to misuse, abuse, negligence, accidents, repairs or alterations or lack of maintenance. This is Grizzly's sole written warranty and any and all warranties that may be implied by law, including any merchantability or fitness, for any particular purpose, are hereby limited to the duration of this written warranty. We do not warrant or represent that the merchandise complies with the provisions of any law or acts unless the manufacturer so warrants. In no event shall Grizzly's liability under this warranty exceed the purchase price paid for the product and any legal actions brought against Grizzly shall be tried in the State of Washington, County of Whatcom.

We shall in no event be liable for death, injuries to persons or property or for incidental, contingent, special, or consequential damages arising from the use of our products.

To take advantage of this warranty, contact us by mail or phone and give us all the details. We will then issue you a "Return Number," which must be clearly posted on the outside as well as the inside of the carton. We will not accept any item back without this number. Proof of purchase must accompany the merchandise.

The manufacturers reserve the right to change specifications at any time because they constantly strive to achieve better quality equipment. We make every effort to ensure that our products meet high quality and durability standards and we hope you never need to use this warranty.

Please feel free to write or call us if you have any questions about the machine or the manual.

Thank you again for your business and continued support. We hope to serve you again soon.

grizzly.com[®]
TOOL WEBSITE

Buy Direct and Save with Grizzly[®] – Trusted, Proven and a Great Value!
~Since 1983~

*Visit Our Website Today For
Current Specials!*

**ORDER
24 HOURS A DAY!
1-800-523-4777**

