



MODEL H8370 POWER FEED FOR MILL/DRILLS INSTRUCTIONS

Specifications

Motor 110V 60Hz
 Speed 0–270 RPM
 Maximum Torque560 in./lb.
 Bevel Gear to Drive Gear Ratio 2.8:1

Inventory

Refer to **Figure 1** and the table below to inventory the contents of the shipping box.

REF	PART #	DESCRIPTION
1V2	PH8370001V2	MOUNTING ASSY W/O WIRES V2.07.11
2	PH8370002	GEAR SAFETY COVER
3V2	PH8370003V2	PWR FEED & LIMIT SWITCH ASSY V2.07.11
4	PH8370004	LIMIT STOP
5	PH8370005	LIMIT SWITCH BRACKET
6	PH8370006	LEADSCREW GEAR
7V2	PH8370007V2	RAPID SWITCH W/LED V2.07.11
8	PH8370008	ZYTEL GEAR

If any nonproprietary parts are missing (e.g. a washer or a spacer), we will gladly replace them; or for the sake of expediency, replacements can be obtained at your local hardware store.

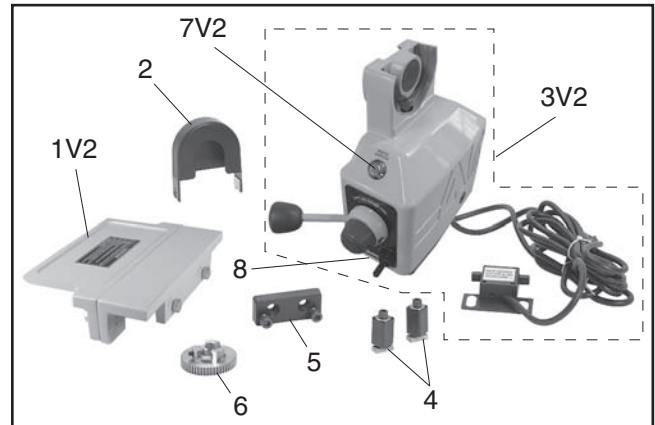

Figure 1. Model H8370 inventory.



If you need help with your new power feed, call our Tech Support at: (570) 546-9663.

Functional Overview

The Model H8370 power feed is designed to install on the left side of a mill/drill table to provide powered longitudinal movement of the table. Refer to **Figures 2–3** and the descriptions below to become familiar with the functional parts of the power feed system.

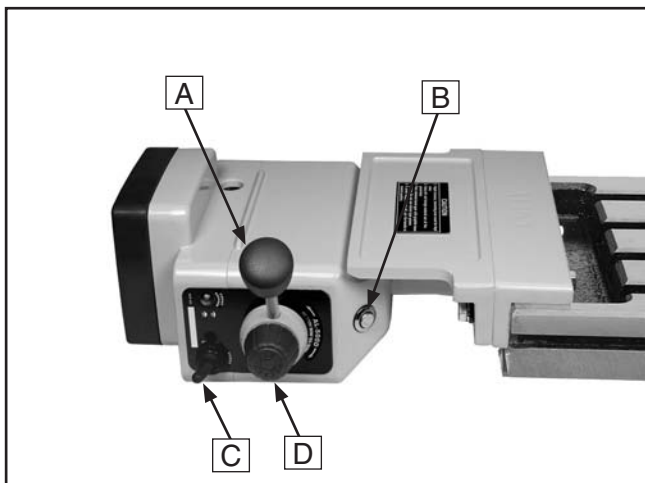

Figure 2. Power feed controls.

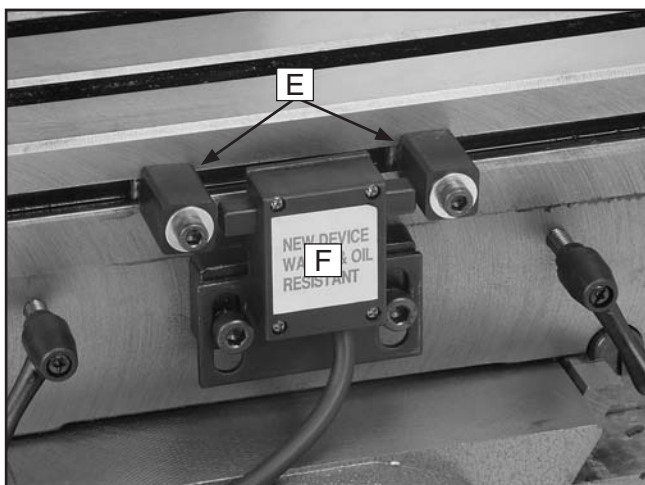

Figure 3. Limit switch and stops.

- A. Direction Lever:** Starts, reverses, and stops longitudinal table movement.
- B. Rapid Movement Button:** Moves the table at the maximum speed in the direction selected. Lights when the power feed is turned **ON**.
- C. ON/OFF Switch:** The master power switch for the power feed.

- D. Speed Dial:** Controls the speed that the table moves—turn the dial clockwise to increase the speed.
- E. Limit Stops:** Activate the limit switch. Secure these devices along the table to set the range of movement.
- F. Limit Switch:** Stops powered table movement when either limit stop presses a plunger on the switch.

Installation

Tools Needed	Qty
Hex Wrench 2.5mm.....	1
Hex Wrench 5mm.....	1
Hex Wrench 6mm.....	1
Wrench 12mm.....	1

To install the power feed:

1. DISCONNECT MILL/DRILL FROM POWER!
2. Remove the handle assembly from the left side of the longitudinal leadscrew.
3. Slide the provided leadscrew gear onto the leadscrew and into the fingers of the coupler, as shown in **Figure 4**, then tighten the set screw of the gear to secure it.

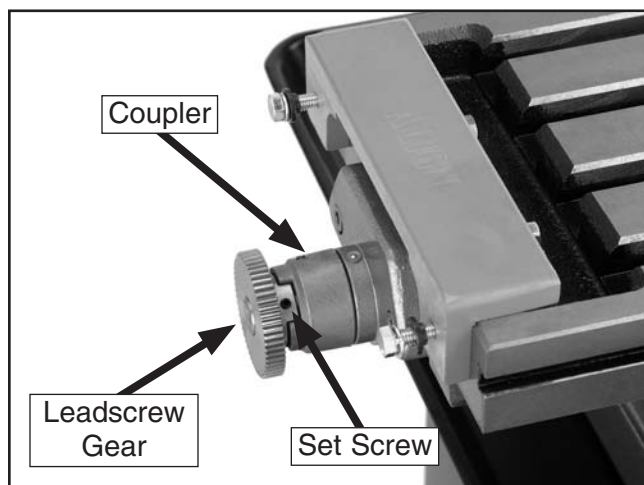

Figure 4. Leadscrew gear installed onto the leadscrew.



- Separate the two pieces of the mounting assembly, then place the table bracket over the lip of the table trough, as shown in **Figure 5**.

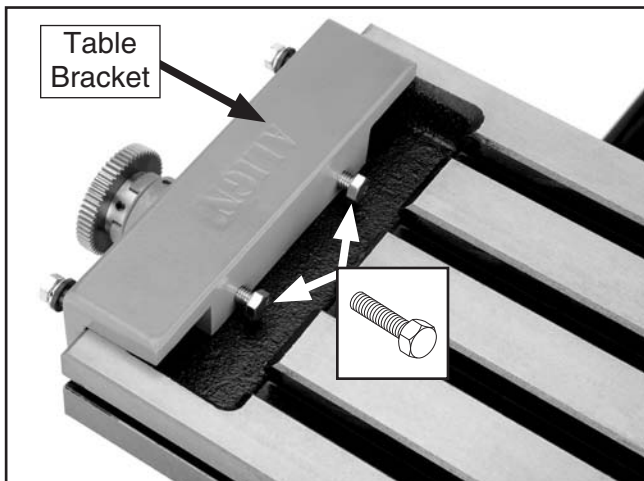

Figure 5. Table bracket mounted on the lip of the table trough.

- Mark the points on the table where the table bracket hex bolts make contact, then remove the bracket from the table.
- Spot drill the points marked in **Step 5** to give the hex bolts a small spot to "bite" the table without slipping on the rough cast surface.
- Set the bracket back on the table and tighten down the hex bolts.
- Install the mounting bracket onto the power feed assembly with the two cap screws provided, as shown in **Figure 6**, but do not yet fully tighten them.

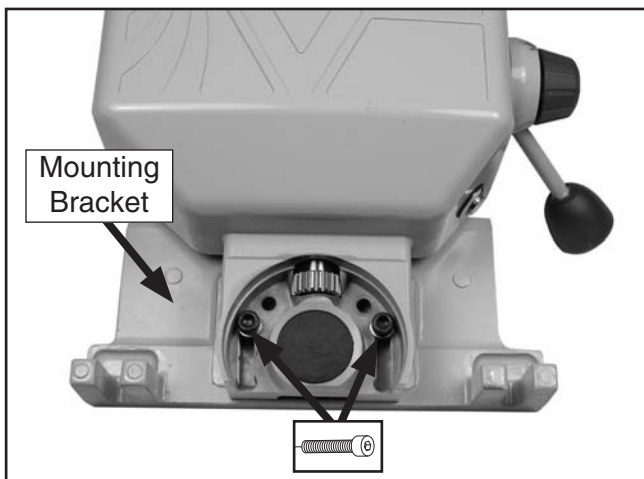

Figure 6. Mounting bracket installed onto the power feed unit.

- Position the assembly from **Step 8** onto the table bracket so that the teeth of the drive gear and the leadscrew gear mesh exactly, then tighten the mounting bracket cap screws and the table bracket hex bolts (see **Figures 7–8**).

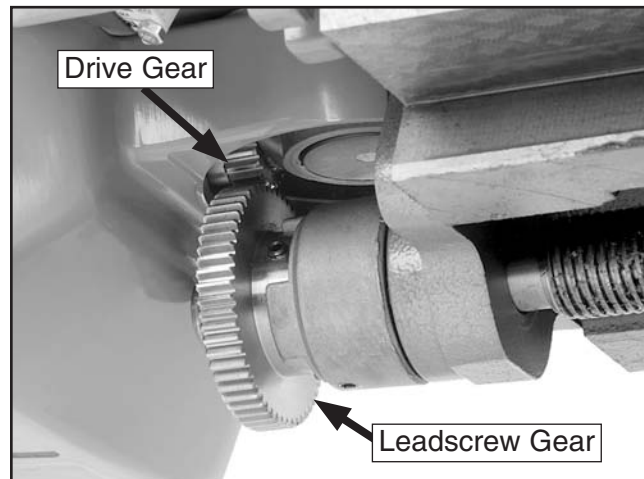

Figure 7. Power feed drive gear and leadscrew gear properly meshed.



Figure 8. Installing the power feed and mounting bracket assembly onto the table bracket.

⚠ CAUTION

Be sure there is enough running clearance between the table, spindle, vise/clamps, or jigs before turning the power feed **ON**. Be aware that all of these objects represent potential pinch points.



- Remove the backing from the adhesive tape on the gear safety cover flanges, then mount the cover on the assembly, as shown in **Figure 9**.

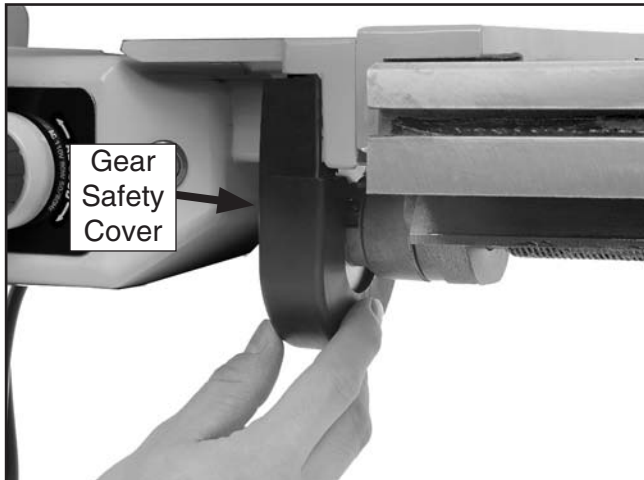

Figure 9. Installing the gear safety cover.

- Slide the T-nuts of the limit stops into the front slot of the table, and position them near the ends of the slots, then tighten the cap screws to secure them in place.
- Install the bracket and limit switch in the center of the saddle, as shown in **Figure 10**, so that the plungers on the sides of the switch align with the limit stops.

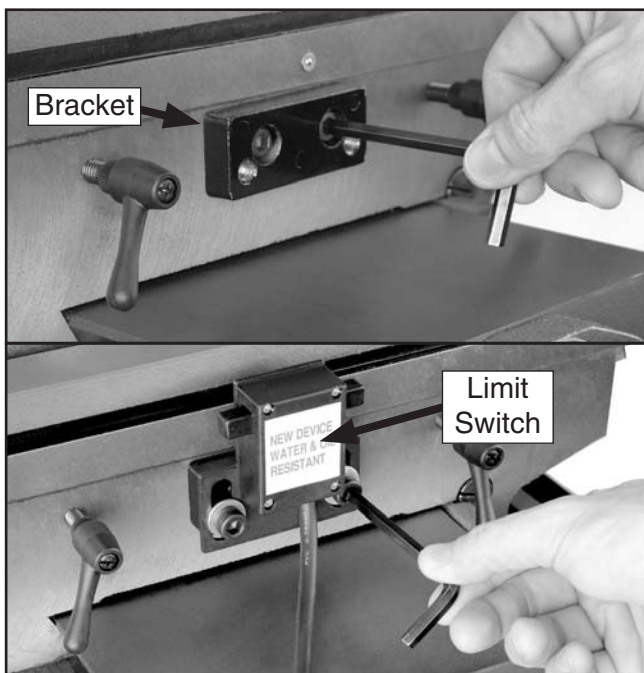
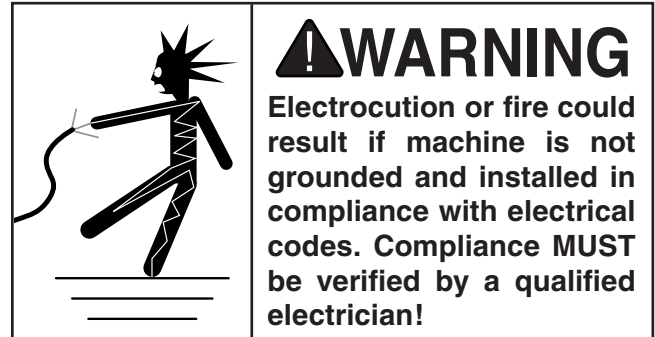

Figure 10. Installing the bracket and limit switch.

- Make sure the ON/OFF switch is in the **OFF** position, then connect the power feed unit to a grounded 110V power source.



Maintenance

Clean and lubricate the power feed gearing every three months of normal use.

- DISCONNECT THE MILL/DRILL AND POWER FEED FROM POWER!
- Remove the gear safety cover.
- Remove the power feed assembly from the table bracket.
- Clean the debris and built-up grime from the drive gear, leadscrew gear, and the surrounding area.
- Brush a light coat of all-purpose grease onto the teeth of the drive and leadscrew gears.
- Re-install the parts removed in reverse order.

