

# *Grizzly* **Industrial, Inc.**®

## **10" HEAVY-DUTY TABLE SAW MODEL G1023S & G1023S110 PARTS LIST**



COPYRIGHT © FEBRUARY 2002 BY GRIZZLY INDUSTRIAL, INC  
**WARNING: NO PORTION OF THIS MANUAL MAY BE REPRODUCED IN ANY SHAPE  
OR FORM WITHOUT THE WRITTEN APPROVAL OF GRIZZLY INDUSTRIAL, INC.**  
REVISED NOVEMBER 2002, PRINTED IN TAIWAN

#### **ONLINE PARTS LIST DISCLAIMER**

THESE PARTS REPRESENT THE CONFIGURATION OF THE MACHINE AS IT IS CURRENTLY BEING SHIPPED. THE MACHINE CONFIGURATION CAN CHANGE AS PRODUCT IMPROVEMENTS ARE INCORPORATED. IF YOU OWN AN EARLIER VERSION OF THE MACHINE, THIS PARTS LIST MAY NOT EXACTLY DEPICT YOUR MACHINE. CONTACT CUSTOMER SERVICE IF YOU HAVE ANY QUESTIONS ABOUT PART DIFFERENCES. PREVIOUS PARTS LIST VERSIONS ARE NOT AVAILABLE ONLINE.

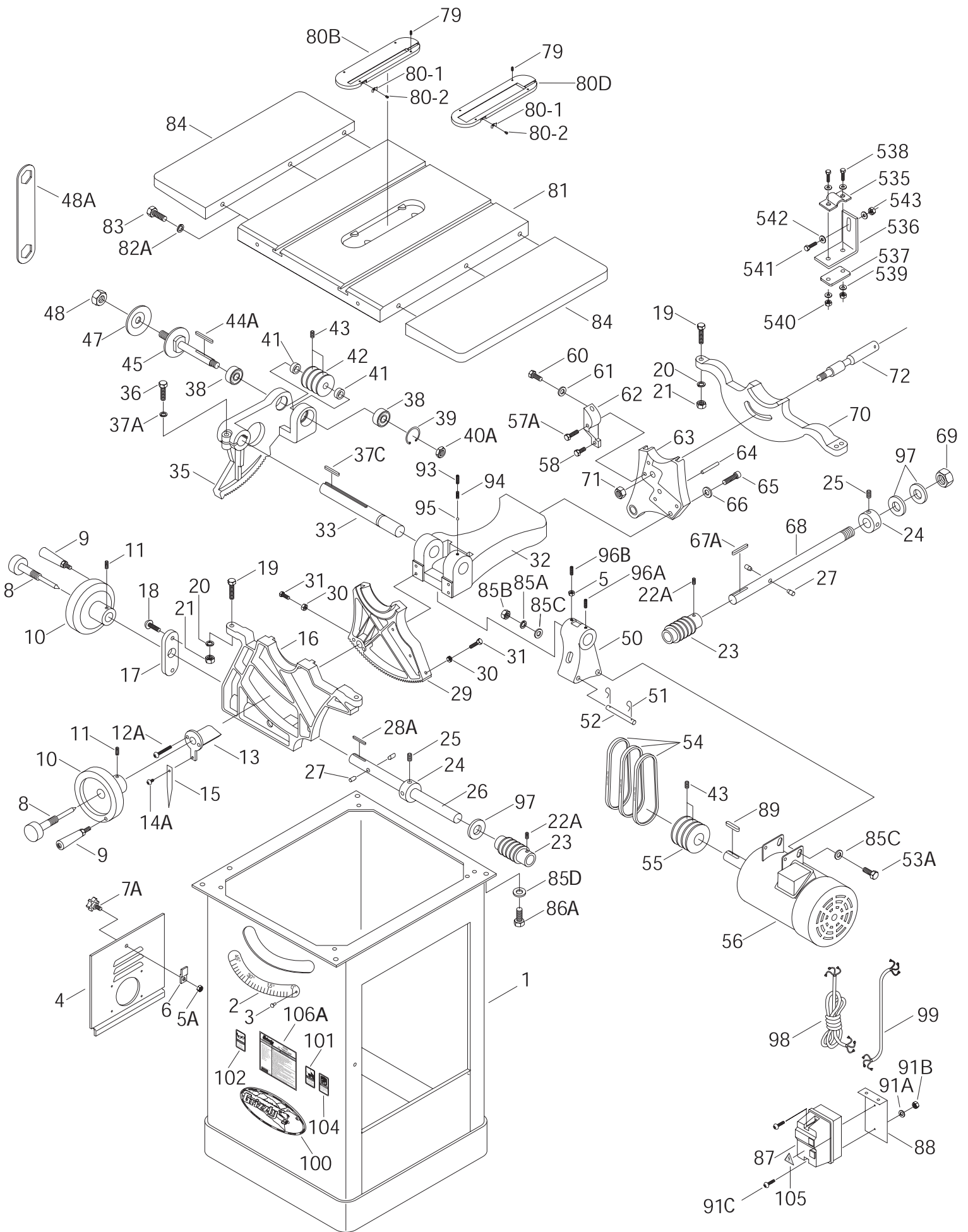

REF#	PART#	DESCRIPTION
001	P1023001	CABINET
002	P1023002	SCALE
003	P1023003	SELF TAPPING SCREW
004	P1023004	CLEANOUT DOOR
005	PV02	HEX NUT 5/16"-18
05A	PN08	HEX NUT 3/8"-16
006	P1023006	DOOR LATCH
07A	P1023007A	KNOB 3/8"-16 X 1 1/2"
008	P1023008	HAND WHEEL LOCK
009	P1023009	HANDLE
010	P1023010	HAND WHEEL
011	PSS04	SETSCREW 1/4"-20 X 5/16"
12A	PSB65	CAP SCREW 10-24 X 2"
013	P1023013	POINTER BRACKET
14A	PS27	PHLP HD SCR 5/16"-18 X 3/8"
015	P1023015	POINTER
016	P1023016	FRONT TRUNNION
017	P1023017	PLATE
018	PS05	PHLP HD SCR 5/16"-18 X 1"
019	PB16	HEX BOLT 3/8"-16 X 1 1/2"
020	PLW04	LOCK WASHER 3/8"
021	PN08	HEX NUT 3/8"-16
22A	PSS03	SETSCREW 1/4"-20 X 3/8"
023	P1023023	WORM
024	P1023024	COLLAR
025	PSS05	SETSCREW 5/16"-18 X 1/4"
026	P1023026	SHAFT
027	P1023027	PIN
28A	PK02M	KEY 5 X 5 X 40
029	P1023029	GEARED TRUNNION
030	PN02	HEX NUT 5/16"-18
031	PB03	HEX BOLT 5/16"-18 X 1"
032	P1023032	FLANGE
033	P1023033	SHAFT
035	P1023035	GEARED BEARING HOUSING
036	PB16	HEX BOLT 3/8"-16 X 1 1/2"
37A	PLW04	LOCK WASHER 3/8"
37C	PK9	KEY 1/4" X 1/4" X 1 1/2"
038	P6203	BEARING 62032RS
039	PR23M	SNAP RING 40
40A	P1023040A	LOCK NUT 5/8"-18
041	P1023041	COLLAR
042	P1023042	ARBOR PULLEY
043	PSS07	SETSCREW 1/4" - 20 x 1/2"
44A	PK02M	KEY 5 X 5 X 45
045	P1023045	BLADE ARBOR
047	P1023047	ARBOR FLANGE
048	P1023048	ARBOR NUT
48A	P1023048A	ARBOR WRENCH
050	P1023050	MOTOR FRAME SUPPORT
051	P1023051	CLIP
052	P1023052	PIVOT PIN
53A	PB75	HEX BOLT 1/2"-13 X 4"
054	P1023054	V-BELTS, SET OF 3
055	P1023055	MOTOR PULLEY

REF#	PART#	DESCRIPTION
056	P1023S110056	MOTOR 2HP 110V
57A	PB76	HEX BOLT 5/16"-18 X 1 5/8"
058	PB03	HEX BOLT 5/16"-18 X 1"
060	PB07	HEX BOLT 5/16"-18 X 3/4"
061	PW07	FLAT WASHER 5/16"
062	P1026062	SUPPORT BRACKET
063	P1023063	FLANGE CASTING
064	PRP03	ROLL PIN 5/16" X 5/8"
065	PSB14	CAP SCREW 3/8"-10 X 1"
066	PW02	FLAT WASHER 3/8"
67A	PK02M	KEY 5 X 5 X 40
068	P1023068	SHAFT
069	PLN05	LOCK NUT 3/4"-16
070	P1023070	REAR TRUNNION
071	P1023040	LOCK NUT 5/8"-18
072	P1023072	BLADE GUARD SUPPORT
079	PSS07	SETSCREW 1/4"-20 X 1/2"
80-1	P1023080-1	SPRING CLIP
80-2	PS06	PHLP HD SCREW 10-24 X 3/8"
80B	P1023080B	STD TABLE INSERT
80D	P1023080D	DADO INSERT
081	P1023081	TABLE
82A	PLW04	LOCK WASHER 3/8"
083	PB24	HEX BOLT 3/8"-16 X 1 1/4"
084	P1023084	EXTENSION WING
85A	PLW07	LOCK WASHER 1/2"
85B	PN13	HEX NUT 1/2"-13
85C	PW01	FLAT WASHER 1/2"
85D	PLW05	LOCK WASHER 7/16"
086	PB77	HEX BOLT 7/16"-20 X 1"
087	G8291(2HP)	SWITCH G1023S110
87A	G4573(3HP)	SWITCH G1023S
088	P1023088	SWITCH MOUNT BRACKET
089	PK02M	KEY 5 X 5 X 40
090	PS201-1	SWITCH COVER SCREW
91C	PS08	PHLP HD SCR 10-24 X 3/4"
91A	PW03	FLAT WASHER #10
91B	PN07	HEX NUT 10-24
093	PSS02	SETSCREW 5/16"-18 X 3/8"
094	P1023094	SPRING
095	P1023095	BALL
96A	PSS08	SETSCREW 5/16"-18 X 1/2"
96B	P1023096	SPECIAL SETSCREW 5/16"-18 X 1 1/4"
097	P1023097	BRASS WASHER
098	P1023098	POWER CORD
099	P1023099	MOTOR CORD
100	P1023100	LOGO PLATE
101	P1023101	DISCONNECT PWR LABEL
102	P1023102	SAFETY GLASSES LABEL
103	P1023103	USE GUARD LABEL
104	P1023104	READ MANUAL LABEL
105	P1023105	ELECTRICITY LABEL
106A	P1023S106A	WARNING ID LABEL G1023S
106A	P1023S110106A	WARNING ID LABEL G1023S110

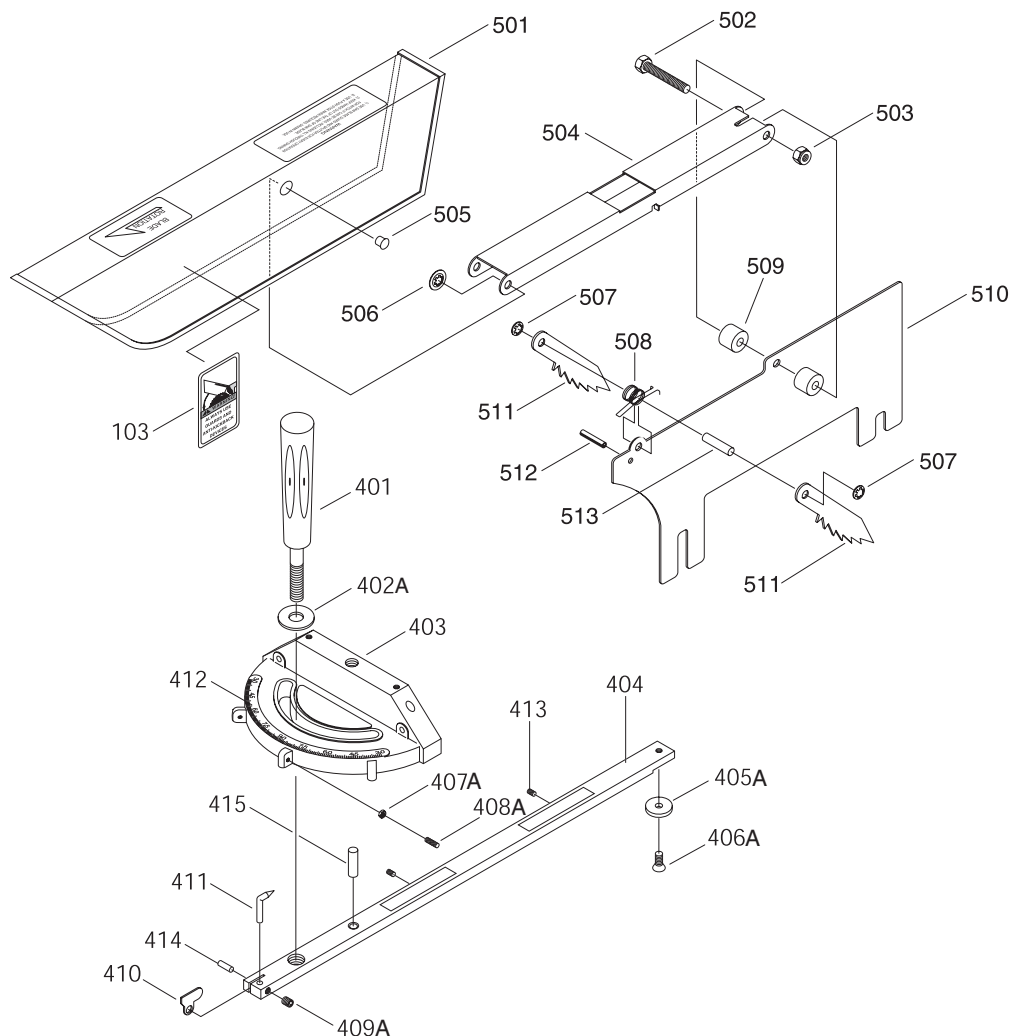

REF#	PART#	DESCRIPTION
400	P1023400	COMPLETE MITER GAUGE
401	P1023401A	KNOB
402A	PW07	FLAT WASHER 5/16"
403	P1023403	MITER GAUGE BODY
404	P1023404A	MITER BAR
405A	P1023405A	RING
406A	PFH26	FLAT HD SCR 10-24 X 1/4"
407A	PN07	HEX NUT 10-24
408A	PSS32	SETSCREW 10-24 X 3/4"
409A	PSS29	SETSCREW 10-24 X 1/4"
410	P1023410	STOP
411	P1023411	POINTER
412	P1023412	SCALE
413	P1023SL413	SETSCREW 10-24 X 5/8"
414	P1023SL414	ROLL PIN 1.5 X 13
415	P1023SL415	MITER HINGE PIN
501	P1022174	GUARD
502	P1022171	HEX BOLT M6-1.0 X 40
503	PLN03M	LOCK NUT M6-1.0

REF#	PART#	DESCRIPTION
504	P1022162	SUPPORTING ARM
505	P1022173	PIVOT PIN
506	P1022175	RETAINER
507	P1022163	RETAINER
508	P1022176	SPRING
509	P1022167	SPACER
510	P1022073	SPLITTER
511	P1022164	PAWL
512	PRP20M	ROLL PIN 4 X 22
513	P1022166	PIN
535	P1023535	U-CLAMP
536	P1023536	L-BRACKET
537	P1023537	LOCKING PLATE
538	PB26	HEX BOLT 1/4"-20 X 1 1/2"
539	PW06	FLAT WASHER 1/4"
540	PN05	HEX NUT 1/4"-20
541	PB07	HEX BOLT 5/16"-18 X 3/4"
542	PW07	FLAT WASHER 5/16"
543	PN02	HEX NUT 5/16"-18