

READ THIS FIRST



Model G1140/G1531
*****IMPORTANT UPDATE*****
 For Machines Mfd. Since 08/14
 and Owner's Manual Revised 04/18

For questions or help with this product contact Tech Support at (570) 546-9663 or techsupport@grizzly.com

The following changes were recently made since the owner's manual was printed:

- Parts and specifications changed.

Aside from this information, all other content in the owner's manual applies and **MUST** be read and understood for your own safety. **IMPORTANT: Keep this update with the owner's manual for future reference.**

For questions or help, contact our Tech Support at (570) 546-9663 or techsupport@grizzly.com.

Revised Parts (G1140)

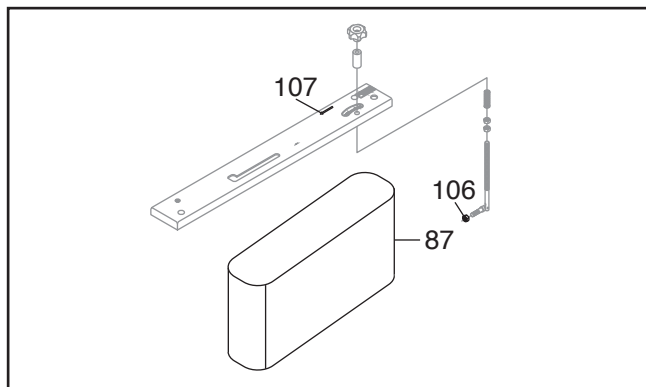

REF	PART #	DESCRIPTION
87	P1140087	BELT 6" X 80" P100
106	P1140106	HEX NUT 3/8-16
107	P1140107	BELT ROTATION LABEL

Revised Parts (G1531)

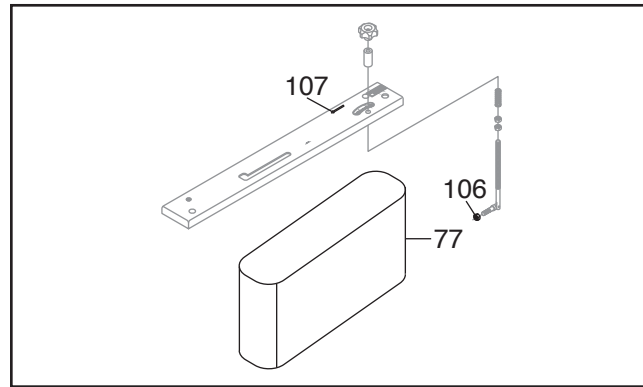

REF	PART #	DESCRIPTION
77	P1531077	BELT 6" X 80" P100
106	P1531106	HEX NUT 3/8-16
107	P1531107	BELT ROTATION LABEL

Revised Specifications (G1140)

Product Dimensions:

Weight 238 lbs.

Shipping Dimensions:

Weight 260 lbs.

Motors:

Main

Horsepower 1-1/2 HP

Main Specifications:

Other Related Information

Mobile Base T28922

Revised Specifications (G1531)

Motors:

Main

Horsepower 1-1/2 HP

COPYRIGHT © JUNE, 2025 BY GRIZZLY INDUSTRIAL, INC.
WARNING: NO PORTION OF THIS MANUAL MAY BE REPRODUCED IN ANY SHAPE OR FORM WITHOUT THE WRITTEN APPROVAL OF GRIZZLY INDUSTRIAL, INC.
 #CM23662 PRINTED IN TAIWAN

G1140 Parts List

REF	PART #	DESCRIPTION
1	P1140001	PLATEN
2	P1140002	PLATEN COVER
3	P1140003	HEX BOLT 3/8-16 X 1-1/2
4	P1140004	LOCK WASHER 3/8
5	P1140005	CAP SCREW 3/8-16 X 1
6	P1140006	DRIVE ROLLER
7	P1140007	HEX NUT 5/8-18
8	P1140008	LOCK WASHER 5/8
9	P1140009	EXT RETAINING RING 3/4
10	P1140010	BALL BEARING 6204ZZ
11	P1140011	RUBBER IDLER ROLLER
11-1	P1140011-1	IDLER ROLLER GUARD
11-2	P1140011-2	FLAT WASHER 1/4
11-3	P1140011-3	SMALL STAR KNOB
12V2	P1140012V2	ROLLER AXLE V2.04.03
13	P1140013	BALL BEARING 6205ZZ
14	P1140014	LOCK WASHER 5/8
15	P1140015	HEX NUT 5/8-11
16	P1140016	AUXILLARY TABLE
17	P1140017	HEX BOLT 5/16-18 X 1/2
17A	P1140017A	SET SCREW 5/16-18 X 5/8
18	P1140018	THUMBSCREW 1/4-20 x 2
19	P1140019	AUXILIARY TABLE POST
20A	P1140020A	ROLLER SUPPORT BRACKET
20B	P1140020B	ROLLER BLOCK BRACKET
20C	P1140020C	FLAT WASHER 3/8
20D	P1140020D	CAP SCREW 3/8-16 X 1-1/2
20E	P1140020E	SET SCREW 1/4-20 X 5/8
21	P1140021	SPECIAL SCREW
22	P1140022	BELT ADJUST SHAFT
23	P1140023	ADJUST SHAFT SLIDE
24	P1140024	CAP SCREW 5/16-18 X 1
25	P1140025	COMPRESSION SPRING 36 X 78
26	P1140026	HEX BOLT 5/16-18 X 3/4
27	P1140027	ARM CONTROL CASTING
28	P1140028	SLEEVE
29	P1140029	CONTROL SHAFT
30	P1140030	SPRING
32	P1140032	HEX NUT 1-8
33	P1140033	TILT KNOB
35A	P1140035A	HEX NUT 3/8-16
36	P1140036	LOCK KNOB 3/8"
38	P1140038	HEX BOLT 5/16-18 X 3/8
39	P1140039	COLLAR
40	P1140040	LEVER
41	P1140041	SWIVEL ASSEMBLY
42	P1140042	PLATE
43	P1140043	KNOB
44A	P1140044A	MITER GAUGE BODY
45	P1140045	KNOB 5/16" X 1"
46A	P1140046A	TABLE V2.07.98
47	P1140047	FLAT WASHER 5/16
48	P1140048	HEX BOLT 5/16-18 X 1
49	P1140049	TILT SLIDES LEFT
49A	P1140049A	TILT SLIDES RIGHT
50	P1140050	SET SCREW 5/16-18 X 1

REF	PART #	DESCRIPTION
51	P1140051	TABLE SUPPORT BRACKET
52	P1140052	SWIVEL LOCK HANDLE 3/8"-16 X 1-1/4"
53	P1140053	TABLE ELEVATION LEADSCREW
55	P1140055	HEX BOLT 5/16-18 X 3/4
56	P1140056	HAND WHEEL
58	P1140058	SPLIT CASTING
59	P1140059	HEX BOLT 3/8-16 X 1
60	P1140060	TABLE ADJ SHAFT
61	P1140061	LOCK WASHER 3/8
62	P1140062	LEVELING ARM SHAFT
63	P1140063	HEX NUT 1/2"-13
64	P1140064	STAND
65	P1140065	PHLP HD SCR 10-24 X 3/4
66	P1140066	FEET
67	P1140067	PHLP HD SCR 8-32 x 1/4
68	P1140068	POINTER
69V2	P1140069V2	MOTOR BRACKET V2.08.14
71	P1140071	MOTOR 1-1/2HP 110/220V 1PH
71-1	P1140071-1	FAN COVER
71-2	P1140071-2	MOTOR FAN
71-3	P1140071-3	CAPACITOR COVER
71-4	P1140071-4	S CAPACITOR 400M 125V 1-7/8 X 3-3/8
71-5	P1140071-5	JUNCTION BOX
71-6	P1140071-6	CONTACT PLT-TUNGSTEN 5HP OR LESS
71-7	P1140071-7	CENT SWITCH 5/8-1725
71-8	P1140071-8	BALL BEARING 6203ZZ
71-9	P1140071-9	BALL BEARING 6205ZZ
72	P1140072	HEX BOLT 5/16-18 X 1-1/4
73	P1140073	HEX NUT 5/16"-18
74	P1140074	FLAT WASHER 5/16
75V2	P1140075V2	GRIZZLY SAFETY PADDLE SWITCH
76	P1140076	LOCK WASHER 5/16
78	P1140078	FLAT WASHER 3/8
79	P1140079	DUST COLLECTION HOOD
80	P1140080	SUPPORT BRACKET DUST HOOD
81	P1140081	ANGLE SCALE
83	P1140083	BELT TENSION LOCK KNOB LABEL
84	P1140084	SPECIAL WASHER 5/8 X 30 X 27
87	P1140087	BELT 6" X 80" P100
88	P1140088	G1140 ID LABEL
89	P1140089	READ MANUAL-VERTICAL NS 7/05
90	P1140090	DISCONNECT 220V 2W X 3.3H
92	P1140092	GRAPHITE PAD 6"W X 29"L
93	P1140093	BELT TRACKING CONTROL LABEL
95	P1140095	POWER CORD 16AWG 3-WIRE 68"L
97	P1140097	SPECIAL SCREW 3/8-16
98V2	P1140098V2	BRACKET V2.08.14
99	P1140099	BACK STOP
100	P1140100	CAP SCREW 3/8-16 X 1
101	P1140101	SPECIAL WASHER 5/8 X 30 X 27
102	P1140102	LOCK BOLT 5/8-11
103	P1140103	FLAT WASHER 1/2
104	P1140104	ELECTRICITY LABEL
105	P1140105	G1140 MOTOR LABEL
106	P1140106	HEX NUT 3/8-16
107	P1140107	BELT ROTATION LABEL



G1531 Parts Breakdown

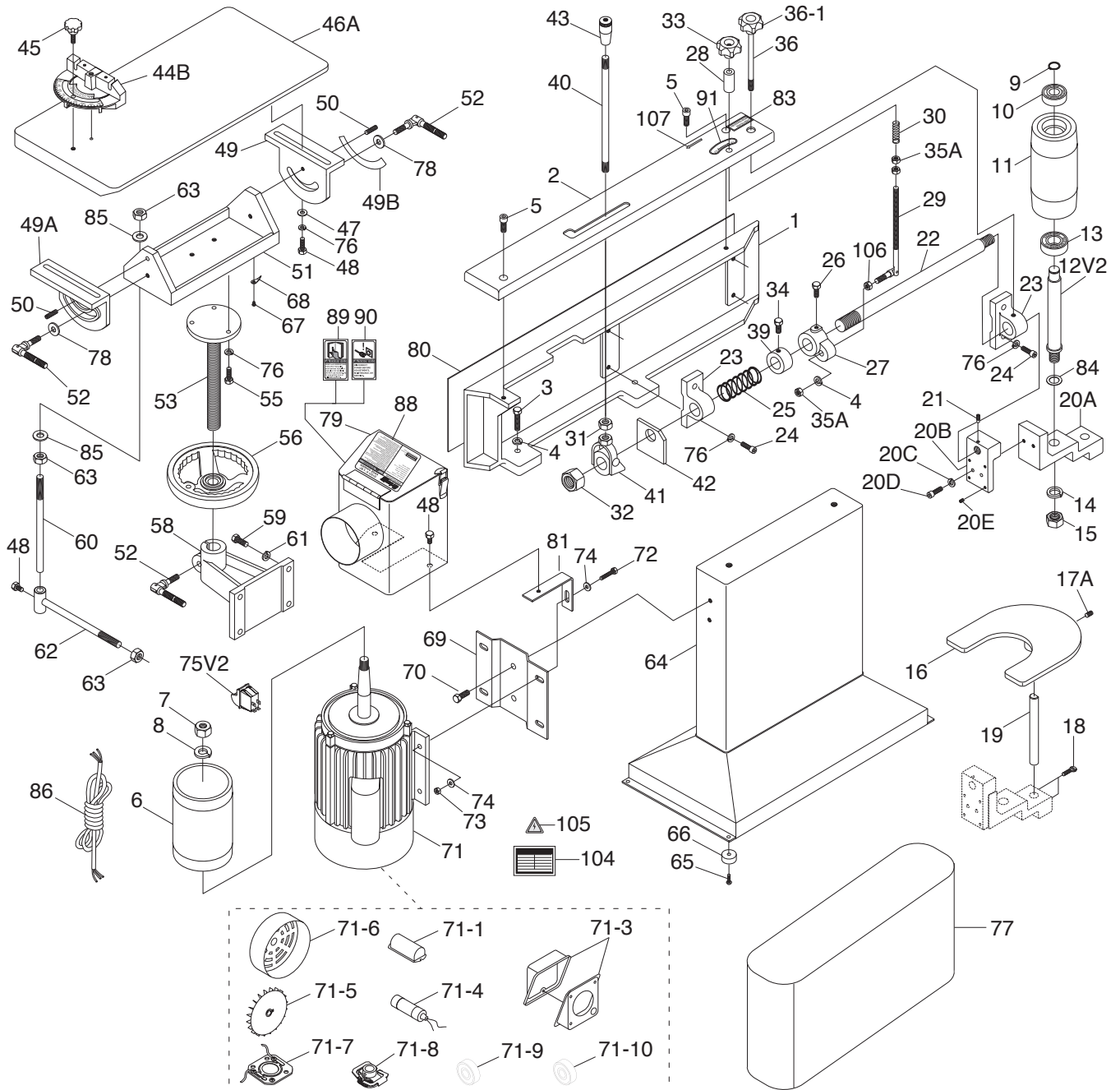

⚠ WARNING

Safety labels help reduce the risk of serious injury caused by machine hazards. If any label comes off or becomes unreadable, the owner of this machine **MUST** replace it in the original location before resuming operations. For replacements, contact (800) 523-4777 or www.grizzly.com.



G1531 Parts List

REF	PART #	DESCRIPTION
1	P1531001	PLATEN
2	P1531002	PLATEN COVER
3	P1531003	HEX BOLT 3/8-16 X 1-1/2
4	P1531004	LOCK WASHER 3/8"
5	P1531005	CAP SCREW 3/8"-16 X 1"
6	P1531006	DRIVE ROLLER
7	P1531007	HEX NUT 5/8"-18
8	P1531008	LOCK WASHER 5/8"
9	P1531009	EXT RETAINING RING 3/4
10	P1531010	BALL BEARING 6204ZZ
11	P1531011	RUBBER IDLER ROLLER
12V2	P1531012V2	ROLLER AXLE V2.04.03
13	P1531013	BALL BEARING 6205ZZ
14	P1531014	LOCK WASHER 5/8"
15	P1531015	HEX NUT 5/8"-11
16	P1531016	AUXILLARY TABLE
17A	P1531017A	SET SCREW 5/16-18 X 5/8
18	P1531018	THUMBSCREW 1/4-20 x 2
19	P1531019	AUXILLARY TABLE POST
20A	P1531020A	ROLLER SUPPORT BRACKET V2.12.97
20B	P1531020B	ROLLER BLOCK BRACKET V2.11.98
20C	P1531020C	FLAT WASHER 3/8
20D	P1531020D	CAP SCREW 3/8"-16 X 1-1/2"
20E	P1531020E	SET SCREW 1/4"-20 X 5/8"
21	P1531021	SPECIAL SCREW 1/4-20 X 5/8
22	P1531022	BELT ADJUST SHAFT
23	P1531023	ADJUST SHAFT SLIDE
24	P1531024	CAP SCREW 5/16"-18 X 1"
25	P1531025	COMPRESSION SPRING 36 X 78
26	P1531026	HEX BOLT 5/16-18 X 3/4
27	P1531027	ARM CONTROL CASTING
28	P1531028	SLEEVE
29	P1531029	CONTROL SHAFT
30	P1531030	SPRING 16.5 X 44
31	P1531031	HEX NUT 1/2"-13
32	P1531032	HEX NUT 1"-8 LH
33	P1531033	TILT KNOB
34	P1531034	HEX BOLT 5/16-18 X 3/8
35A	P1531035A	HEX NUT 3/8"-16
36	P1531036	KNOB W/SHAFT
36-1	P1531036-1	KNOB
39	P1531039	COLLAR
40	P1531040	LEVER
41	P1531041	SWIVEL ASSY
42	P1531042	PLATE
43	P1531043	KNOB
44B	P1531044B	MITER STOP V1.10.95
45	P1531045	KNOB 5/16-18 X 1"
46A	P1531046A	TABLE V2.07.98
47	P1531047	FLAT WASHER 5/16"
48	P1531048	HEX BOLT 5/16-18 X 1/2
49	P1531049	TILT SLIDES LEFT
49A	P1531049A	TILT SLIDES RIGHT

REF	PART #	DESCRIPTION
49B	P1531049B	ANGLE SCALE
50	P1531050	SET SCREW 5/16"-18 X 1"
51	P1531051	TABLE SUPPORT BRACKET
52	P1531052	SWIVEL LOCK HANDLE 3/8"-16 X 1-1/4"
53	P1531053	LEAD SCREW 1"-4
55	P1531055	HEX BOLT 5/16-18 X 3/4
56	P1531056	HANDWHEEL
58	P1531058	SPLIT CASTING
59	P1531059	HEX BOLT 3/8-16 X 1
60	P1531060	TABLE ADJ SHAFT
61	P1531061	LOCK WASHER 3/8
62	P1531062	LEVELING ARM SHAFT
63	P1531063	HEX NUT 1/2"-13
64	P1531064	BASE
65	P1531065	PHLP HD SCR 10-24 X 3/4
66	P1531066	FEET
67	P1531067	PHLP HD SCR 8-32 x 1/4
68	P1531068	POINTER
69	P1531069	MOTOR BRACKET
70	P1531070	HEX BOLT 3/8-16 X 1
71	P1531071	MOTOR 1-1/2HP 110/220V 1PH
71-1	P1531071-1	CAPACITOR COVER
71-3	P1531071-3	CONNECTION BOX CASE
71-4	P1531071-4	S CAPACITOR 400M 125V 1-7/8 X 3-3/8
71-5	P1531071-5	MOTOR FAN
71-6	P1531071-6	FAN COVER
71-7	P1531071-7	CONTACT PLT-TUNGSTEN 5HP OR LESS
71-8	P1531071-8	CENT SWITCH 5/8-1725
71-9	P1531071-9	BALL BEARING 6203ZZ
71-10	P1531071-10	BALL BEARING 6205ZZ
72	P1531072	HEX BOLT 5/16-18 X 1-1/4
73	P1531073	HEX NUT 5/16"-18
74	P1531074	FLAT WASHER 5/16"
75V2	P1531075V2	GRIZZLY SAFETY PADDLE SWITCH
76	P1531076	LOCK WASHER 5/16"
77	P1531077	BELT 6" X 80" P100
78	P1531078	FLAT WASHER 3/8"
79	P1531079	DUST COLLECTION HOOD
80	P1531080	GRAPHITE PAD 6"W X 29"L
81	P1531081	DUST HOOD SUPPORT BRACKET
83	P1531083	BELT TENSION LOCK KNOB LABEL
84	P1531084	SPECIAL WASHER 5/8 X 30 X 27
85	P1531085	FLAT WASHER 1/2"
86	P1531086	POWER CORD
88	P1531088	G1531 ID LABEL
89	P1531089	READ MANUAL-VERTICAL NS 7/05
90	P1531090	DISCONNECT 220V 2W X 3.3H
91	P1531091	BELT TRACKING CONTROL LABEL
104	P1531104	ELECTRICITY LABEL
105	P1531105	G1531 MOTOR LABEL
106	P1531106	HEX NUT 3/8-16
107	P1531107	BELT ROTATION LABEL

