

## Maintenance

Your BOARD BUDDIES® are engineered for dependable service and ease of operation. However with most shop tools, they may need periodic inspection and cleaning.

- **NEVER** lubricate Board Buddy parts. Oil will attract sawdust and foreign material which could jam the mechanism or stain your workpiece.
- **ALWAYS** make sure the jam nuts (5) and the position locking thumbscrews (11) are tight, and the BOARD BUDDIES® are correctly adjusted.

## Troubleshooting

Here are some common solutions for Board Buddy problems:

The Board Buddy does not clamp down on the stock as it should, the pivot arm binds, or the roller tension does not adjust correctly.

1. Refer to the **Safety and Operation** section and re-adjust the Board Buddy correctly.
2. Remove and clean the threads of the adjusting screws and thumbscrews. Replace any stripped adjustment screws and re-adjust.
3. Depress the pivot arm (1) and remove the shoe (7). Clean out any foreign material that is preventing the shoe from sliding inside the housing (2). See **Figure 4**.

4. Replace the shoe if it is broken or worn.

The Board Buddy roller does not lock rotation.

1. Incorrect roller, replace the roller with the correct roller.
2. The roller is broken. Replace the roller with a new one. **DO NOT** rebuild the rollers.

## Parts List

Use **Figure 4** and the parts list to inventory your package. Your new BOARD BUDDIES® are carefully packed. However, if any part is damaged or missing, contact Woodstock International Service and Support at 1-360-734-3482 or send e-mail to: [tech-support@shopfox.biz](mailto:tech-support@shopfox.biz).

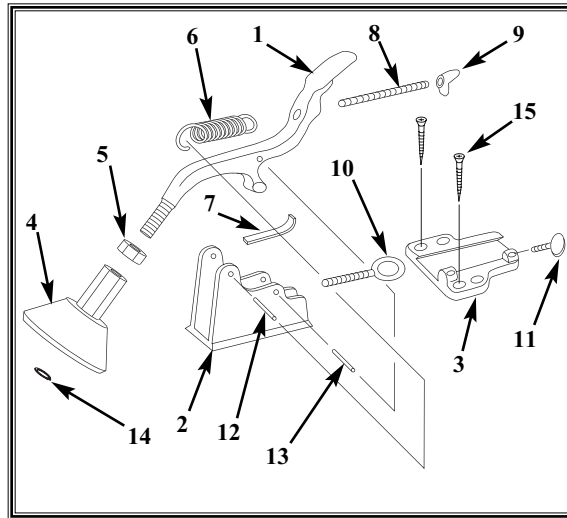

**Figure 4.** Board Buddy Parts.

ITEM	PART #	DESCRIPTION
1	X1104001	PIVOT ARM
2	X1104002	HOUSING
3	X1104003	MOUNTING BRACKET
4	X1104004	ROLLER (YELLOW)
5	X1104005	LOCK NUT ½"-20
6	X1104006	SPRING
7	X1104007	SHOE
8	X1104008	TIE ROD ⅝"-18 x 2-½"
9	X1104009	WING NUT ⅝"-18
10	X1104010	ADJUST ROD ⅝"-18 x 2"
11	X1104011	THUMBSCREW ¼"-20 x ¾"
12	XPRP25M	ROLL PIN 5 X 20MM
13	XPRP07M	PIVOT PIN 6 X 20MM
14	XPR02M	EXT RETAINING RING 9MM
15	XPHTEK13	WOOD SCREW #10 X 1-½"



# BOARD BUDDIES®

## INSTRUCTION MANUAL ANTI-KICKBACK HOLDDOWN DEVICES (PART # W1104)

### Introduction

**BOARD BUDDIES®** are made from die-cast aluminum and feature non-marring yellow neoprene rubber wheels. Because the wheels turn clockwise only, they function as anti-kickback and holddown devices. You can mount these to fences that are 3" (76.2mm) to 1½" (38.1mm) high x 1" (25.4mm) or wider. Each Board Buddy consists of a mounting bracket, a main body, and a roller. The main body has a pivot arm which accepts the roller, a housing which contains the pivot point and a roller pressure spring. See **Figure 1**.

## ⚠ WARNING

**Read and understand your machine operators manual, and know the machine limitations. NO ANTI-KICKBACK DEVICE WILL MAKE YOUR MACHINE COMPLETELY SAFE!**

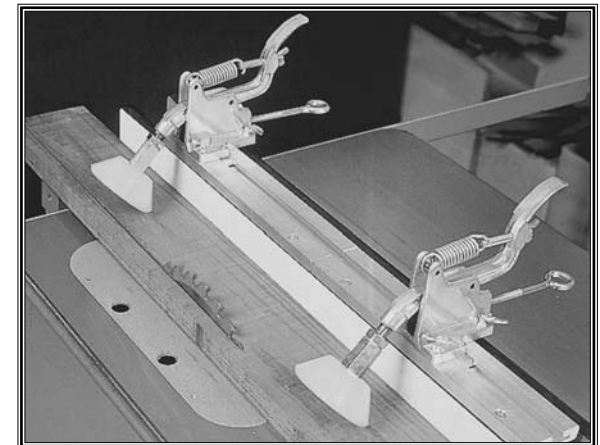

**Figure 1.** Typical Board Buddy application.