



MODEL G2909 2 HP ELECTRIC MOTOR INSTRUCTIONS

For questions or help with this product contact Tech Support at (570) 546-9663 or techsupport@grizzly.com

Model G2909 Specifications

Power	2 HP
Cycle.....	60Hz
Voltage.....	110/220V
Prewired	110V
Amps	18.6A/9.3A
RPM.....	3450
Phase	Single
Class.....	E

Parts

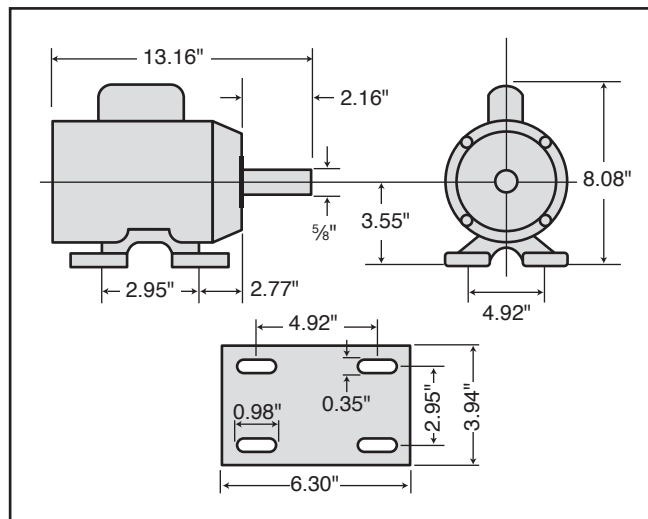
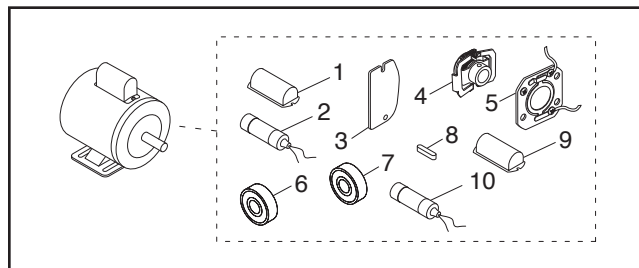

REF PART # DESCRIPTION

REF	PART #	DESCRIPTION
1	P2909001	S CAPACITOR COVER
2	P2909002	S CAPACITOR 400M 250V 1-3/4 X 3-3/8
3	P2909003	WIRING COVER PLATE
4	P2909004	CENTRIFUGAL SWITCH 1/2-3450
5	P2909005	CONTACT PLATE
6	P2909006	BALL BEARING 6202ZZ
7	P2909007	BALL BEARING 6203ZZ
8	P2909008	KEY 3/16 X 3/16 X 1-1/4
9	P2909009	R CAPACITOR COVER
10	P2909010	R CAPACITOR 40M 250V 1-3/8 X 2-3/8

Making Wire Connections

If you are unsure how to attach wires to terminals, DO NOT continue. Contact an electrician for assistance. Connecting wires improperly may cause them to come loose or contact other wires, which can cause electrocution, fire, or a short.

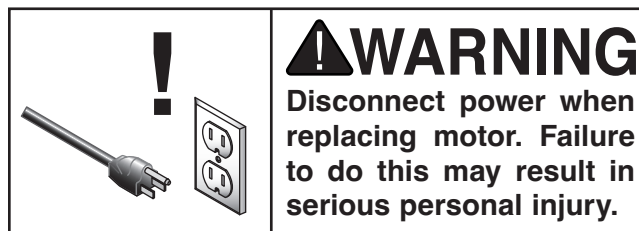
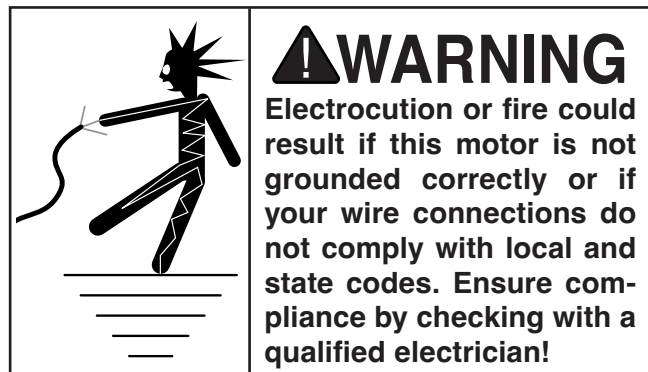

COPYRIGHT © DECEMBER, 2007 BY GRIZZLY INDUSTRIAL, INC., REVISED APRIL, 2024 (LW)
WARNING: NO PORTION OF THIS INSTRUCTION SHEET MAY BE REPRODUCED IN ANY SHAPE
OR FORM WITHOUT THE WRITTEN APPROVAL OF GRIZZLY INDUSTRIAL, INC.

#JB10221 PRINTED IN TAIWAN

Keep for Future Reference