

# SECTION VIII: PART DIAGRAM

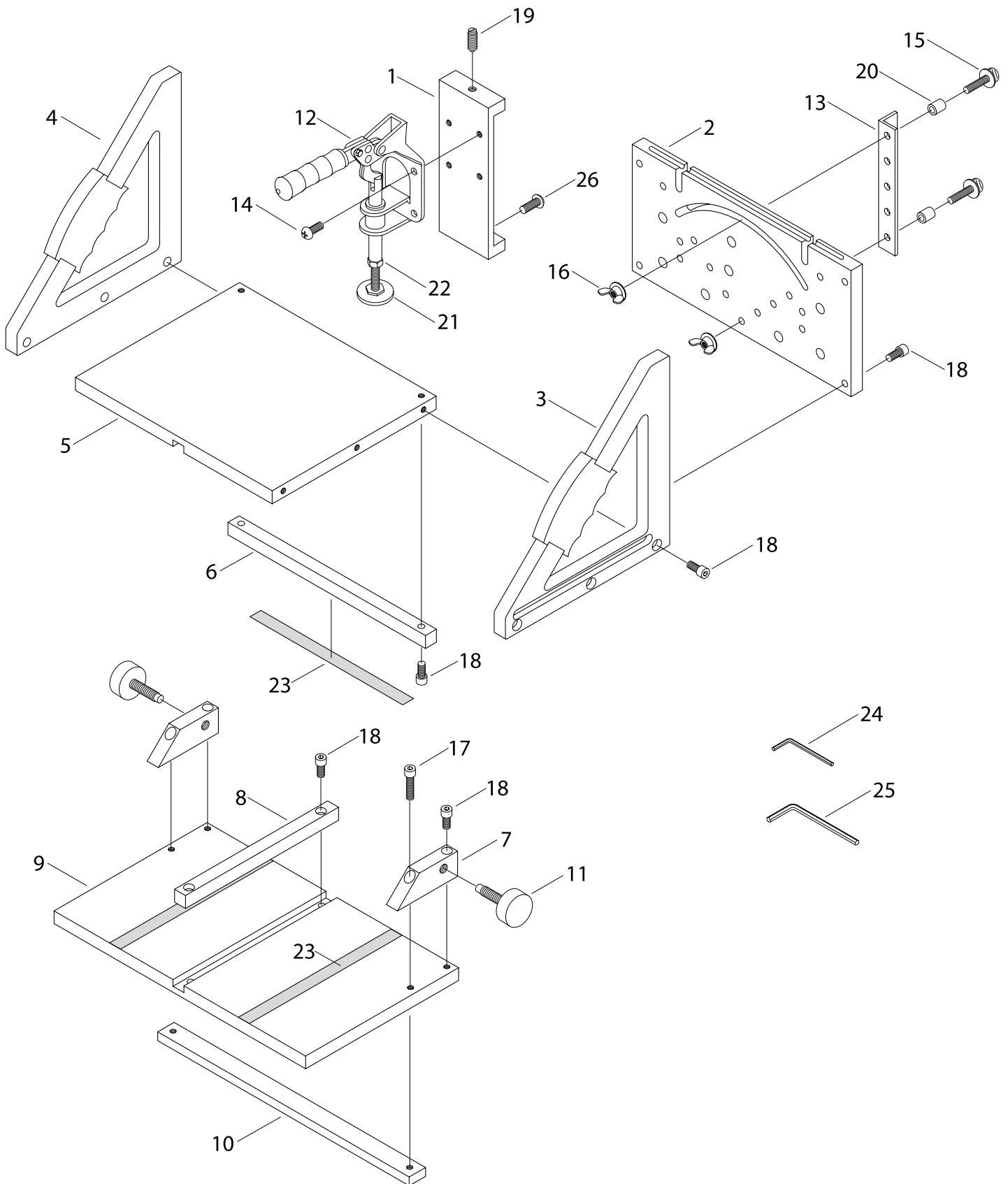

# SECTION IX: PART LIST

PART #	DESCRIPTION
1	HOLD DOWN BRACKET
2	FACE PLATE
3	SIDE HAND-HOLD (RIGHT)
4	SIDE HAND-HOLD (LEFT)
5	SLIDING TABLE
6	SLIDING TABLE SUPPORT
7	LOCKING KNOB BRACKETS
8	SLIDING RAIL
9	BASE PLATE
10	MITER BAR
11	LOCK KNOBS
12	TOGGLE CLAMP
13	ANGLE BRACKET
14	10 - 32 x $\frac{3}{8}$ " BUTTON HD SCREWS
15	$\frac{1}{4}$ " - 20 x $1\frac{3}{4}$ " THUMB SCREWS
16	$\frac{1}{4}$ " - 20 WING NUTS
17	$\frac{1}{4}$ " - 20 x 1" CAP SCRW
18	$\frac{1}{4}$ " - 20 x $\frac{1}{2}$ " CAP SCRW
19	$\frac{1}{4}$ " - 20 x $\frac{1}{2}$ " BALL PLUNGER
20	$\frac{1}{2}$ " x $\frac{1}{4}$ " x $\frac{5}{8}$ " ALUMINUM BUSHING
21	PLUNGER
22	$\frac{5}{16}$ " - 18 HEX NUT
23	$\frac{1}{2}$ " TEFLON TAPE
24	$\frac{1}{8}$ " ALLEN® WRENCH
25	$\frac{3}{16}$ " ALLEN® WRENCH
26	BUTTON HEAD SCREW