

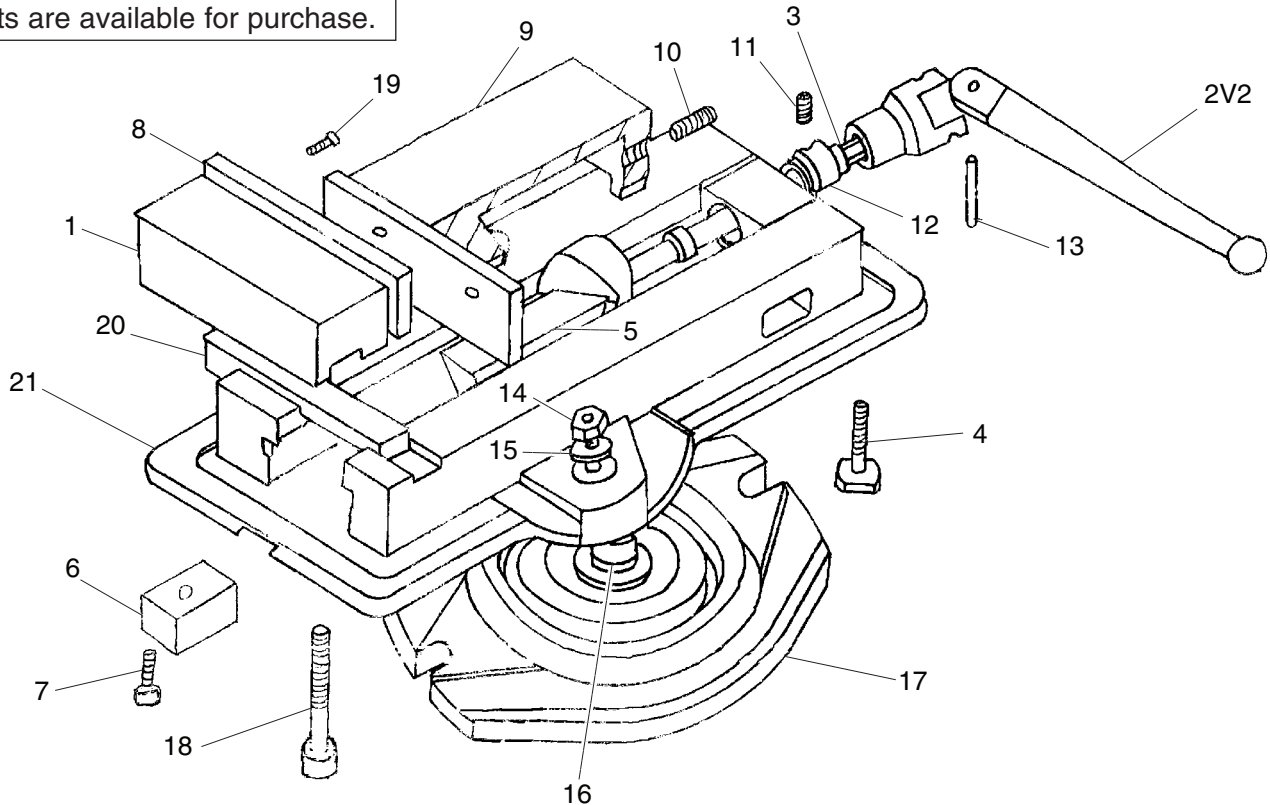

MODEL G7156 4" MILLING VISE PARTS INFORMATION

Parts information is provided for service purposes only. Not all parts are available for purchase.



REF	PART #	DESCRIPTION
1	P7156001	FIXED JAW
2V2	P7156002V2	HANDLE 8-1/4 X 9/16 V2.05.06
3	P7156003	LEADSCREW
4	P7156004	T-BOLT M10-1.5 X 40
5	P7156005	LEADSCREW BRACKET
6	P7156006	ALIGNMENT BLOCK
7	PCAP26M	CAP SCREW M6-1 X 12
8	P7156008	JAW FACE
9	P7156009	MOVABLE JAW
10	PSS14M	SET SCREW M8-1.25 X 12
11	PSS02M	SET SCREW M6-1 X 6

REF	PART #	DESCRIPTION
12	P7156012	RING BLOCK
13	P7156013	ROLL PIN
14	PN02M	HEX NUT M10-1.5
15	PW04M	FLAT WASHER 10MM
16	P7156016	PIVOT BOLT
17	P7156017	PIVOT BASE
18	PCAP83M	CAP SCREW M6-1 X 55
19	PCAP50M	CAP SCREW M5-.8 X 10
20	P7156020	KEY
21	P7156021	WISE BASE

COPYRIGHT © AUGUST, 2009 BY GRIZZLY INDUSTRIAL, INC.
**WARNING: NO PORTION OF THIS DOCUMENT MAY BE REPRODUCED IN ANY SHAPE
OR FORM WITHOUT THE WRITTEN APPROVAL OF GRIZZLY INDUSTRIAL, INC.**

#TS12058 PRINTED IN CHINA